

***ARMY TM 10-1670-276-23&P
AIR FORCE T.O. 13C5-29-2
NAVY NAVAIR 13-1-29**

TECHNICAL MANUAL

**FIELD MAINTENANCE MANUAL
(INCLUDING REPAIR PARTS AND SPECIAL TOOLS LIST)
FOR**

**PARACHUTE, CARGO TYPE:
26-FOOT DIAMETER, HIGH-VELOCITY
CARGO PARACHUTE
NSN 1670-00-872-6109**

DISTRIBUTION STATEMENT A. – Approved for public release; distribution is unlimited.

***This manual supersedes TM 10-1670-276-23&P, dated 28 September 1990.**

HEADQUARTERS, DEPARTMENT OF THE ARMY

14 MARCH 2008

WARNING SUMMARY

This warning summary contains general safety warnings and hazardous material warnings that must be understood and applied during operation and maintenance of the equipment. Failure to observe these precautions could result in serious injury or death to personnel or damage to equipment. For First Aid treatment, refer to FM 4-25.11

WARNING

Failure to detect areas of damage may result in malfunction of the parachute and/or loss of equipment.

WARNING

Exercise extreme care when using petroleum products to destroy equipment by fire, as these materials are highly flammable. Improper handling may cause injury to personnel.

WARNING

Inspect the deployment bag and the entire static line, including that portion under sleeve. Failure to do so may cause serious damage or loss of equipment.

WARNING

Due to flammable properties and nylon-damaging substances, cleaning solvents, other than EVERBLUM GOLD™ (industrial cleaner), will not be used in the spot-cleaning of airdrop equipment. EVERBLUM GOLD™ will only be used in the areas where substantial ventilation is available. Repeated or prolonged inhalation of the solvent vapors can be detrimental to human health. In addition, avoid prolonged or repeated skin contact with the solvent fluid. EVERBLUM BOLD™ must not be taken internally.

WARNING

Proper breakaway/non-breakaway packing is required. Failure to properly pack/rig may result in malfunction in the extraction or deployment phase. Failure to observe these precautions could result in injury to personnel and/or damage to equipment may occur.

LIST OF EFFECTIVE PAGES/WORK PACKAGES

Note: *This manual supersedes TM 10-1670-276-23&P dated 28 September 1990. Zero in the "Change No." column indicates an original page or work package.

Date of issue of the original manual is:

Original 14 March 2008

TOTAL NUMBER OF PAGES FOR FRONT AND REAR MATTER IS 30 AND TOTAL NUMBER OF WORK PACKAGES IS 51, CONSISTING OF THE FOLLOWING:

Page/WP No.	Change No.	Page/WP No.	Change No.
Front Cover	0	WP 0026 (4 pgs)	0
a – b	0	WP 0027 (6 pgs)	0
Warning summary (2 pgs)	0	WP 0028 (2 pgs)	0
i – x	0	WP 0029 (2 pgs)	0
Chp 1 title page	0	WP 0030 (2 pgs)	0
WP 0001 (6 pgs)	0	WP 0031 (2 pgs)	0
WP 0002 (2 pgs)	0	WP 0032 (4 pgs)	0
Chp 2 title page	0	WP 0033 (2 pgs)	0
WP 0003 (10 pgs)	0	WP 0034 (10 pgs)	0
WP 0004 (2 pgs)	0	WP 0035 (2 pgs)	0
WP 0005 (2 pgs)	0	WP 0036 (6 pgs)	0
WP 0006 (4 pgs)	0	WP 0037 (6 pgs)	0
Chp 3 title page	0	Chp 4 title page	0
WP 0007 (4 pgs)	0	WP 0038 (6 pgs)	0
WP 0008 (4 pgs)	0	WP 0039 (4 pgs)	0
WP 0009 (4 pgs)	0	WP 0040 (4 pgs)	0
WP 0010 (2 pgs)	0	WP 0041 (4 pgs)	0
WP 0011 (28 pgs)	0	WP 0042 (4 pgs)	0
WP 0012 (6 pgs)	0	WP 0043 (4 pgs)	0
WP 0013 (2 pgs)	0	WP 0044 (2 pgs)	0
WP 0014 (2 pgs)	0	WP 0045 (2 pgs)	0
WP 0015 (2 pgs)	0	WP 0046 (2 pgs)	0
WP 0016 (2 pgs)	0	WP 0047 (2 pgs)	0
WP 0017 (4 pgs)	0	Chp 5 title page	0
WP 0018 (2 pgs)	0	WP 0048 (2 pgs)	0
WP 0019 (2 pgs)	0	WP 0049 (8 pgs)	0
WP 0020 (2 pgs)	0	WP 0050 (4 pgs)	0
WP 0021 (2 pgs)	0	WP 0051 (2 pgs)	0
WP 0022 (2 pgs)	0	INDEX 1 – INDEX 3	0
WP 0023 (2 pgs)	0	Back Cover	0
WP 0024 (6 pgs)	0		
WP 0025 (2 pgs)	0		

HEADQUARTERS, DEPARTMENTS
OF THE ARMY, THE AIR FORCE
AND THE NAVY
WASHINGTON, D.C., 14 MARCH 2008

TECHNICAL MANUAL

FIELD MAINTENANCE MANUAL
(INCLUDING REPAIR PARTS AND SPECIAL TOOLS LIST)
FOR
PARACHUTE, CARGO TYPE:
26-FOOT DIAMETER, HIGH-VELOCITY
CARGO PARACHUTE
NSN 1670-00-872-6109

REPORTING ERRORS AND RECOMMENDING IMPROVEMENTS

You can help improve this manual. If you find any mistakes or if you know of a way to improve the procedures, please let us know. Reports, as applicable by the requiring Service, should be submitted as follows:

a. (A) Army – Mail your letter or DA Form 2028 (Recommended Changes to Publications and Blank Forms), located in the back of this manual directly to: Commander, TACOM-Life Cycle Management Command, ATTN: AMSTA-LC-SECT 15 Kansas Street, Natick, MA 01760-5052. You may also send in your recommended changes via electronic mail or by fax. Our fax number is DSN 256-5205. Our e-mail address is soldier.pubs@us.army.mil.

b. (F) Air Force – By Air Force AFTO Form 22 (Technical Order Publication Improvement Report and Reply) and forwarded to the address prescribed above for the Army. An information copy of the prepared AFTO Form 22 shall be furnished to WP-ALC/TILTA, 420 2nd St., Suite 100, Robins AFB, GA 31098-1640.

c. (N) Navy – Submit NAVSEA Form 416011 (REV 2-99) to Commander, NSDSA Code 5E30, NAVSURFCENDIV, 4363 Missile Way, Port Hueneme, CA 93043-4307). A reply will be sent to you.

* This manual supersedes TM 10-1670-276-23&P, dated 28 September 1990, including all changes.

DISTRIBUTION STATEMENT A – Approved for public release; distribution is unlimited.

TABLE OF CONTENTS

	<u>WP Sequence No.</u>
	<u>Page No.</u>
Warning Summary	
How To Use This Manual	
Chapter 1 – General Information, Equipment Description and Theory of Operation	
General Information.....	WP 0001
Figure 1. 26-Foot Diameter Cargo Parachute.....	WP 0001-1
Chapter 2 – Maintenance Instructions	
Equipment Description and Data.....	WP 0002
Figure 1. The 26-Foot Diameter, High-Velocity Cargo Parachute, with Deployment Bag.....	WP 0002-1
Service Upon Receipt.....	WP 0003
Figure 1. Installing Attaching Tie.....	WP 0003-3
Figure 2. Corner Attaching Hole.....	WP 0003-4
Figure 3. Log Record Attachment Tie Completed.....	WP 0003-5
Figure 4. Log Record Form.....	WP 0003-6
Figure 5. Modification Work Order Record Page.....	WP 0003-7
Figure 6. Modification Work Order Completed.....	WP 0003-7
Figure 7. Note Page.....	WP 0003-8
Assembling the 26-Foot Diameter, High-Velocity Cargo Parachute Assembly.....	WP 0004
Preventive Maintenance Checks and Services (PMCS), Introduction	WP 0005
Preventive Maintenance Checks and Services (PMCS)	WP 0006
Table 1. Preventive Maintenance Checks and Services (PMCS).....	WP 0006-2
Chapter 3 – Service Maintenance Instructions	
Shakeout and Airing	WP 0007
Figure 1. Attaching Rope to Canopy.....	WP 0007-1
Figure 2. First Gore.....	WP 0007-2
Figure 3. Entanglement.....	WP 0007-2

	<u>WP Sequence No.</u>
	<u>Page No.</u>
Figure 4. S-Fold Suspension Lines.....	WP 0007-3
Cleaning and Drying.....	WP 0008
Inspection.....	WP 0009
Salt-Water/Fresh-Water Contamination Test.....	WP 0010
Packing Procedures.....	WP 0011
Figure 1. Rigger's View.....	WP 0011-2
Figure 2. Canopy Attached to Packing Table Apex Hook.....	WP 0011-3
Figure 3. Removing Inversion.....	WP 0011-4
Figure 4. Removing Partial Inversion.....	WP 0011-5
Figure 5. Removing Turns.....	WP 0011-5
Figure 6. Removing Tangles.....	WP 0011-6
Figure 7. Removing Twists.....	WP 0011-7
Figure 8. Suspension Line Separation.....	WP 0011-8
Figure 9. Attaching Static Line to Deployment Bag.....	WP 0011-9
Figure 10. Flipping Right Gore Group.....	WP 0011-10
Figure 11. Right Gore Group Fold Complete.....	WP 0011-10
Figure 12. Draping Folded Gores to Right Side of Table.....	WP 0011-11
Figure 13. Folding Completed, Lines Separated.....	WP 0011-12
Figure 14. Canopy in Flat Fold.....	WP 0011-13
Figure 15. Canopy Longfolded.....	WP 0011-14
Figure 16. Attaching Cotton Deployment Bag for Non-Breakaway Static Lines.....	WP 0011-16
Figure 17. Attaching Cotton Deployment Bag Retaining Tie and Breakaway Static Lines.....	WP 0011-17
Figure 18. Attaching Nylon Bag for Non-Breakaway Static Line.....	WP 0011-18
Figure 19. Retaining Tie.....	WP 0011-19

	<u>WP Sequence No.</u>
	<u>Page No.</u>
Figure 20. USL Snap Hook Cord Connection.....	WP 0011-19
Figure 21. Canopy Stowage Completed.....	WP 0011-20
Figure 22. Bag Closing Tie Completed.....	WP 0011-21
Figure 23. First Suspension Line Stow.....	WP 0011-22
Figure 24. First and Second Suspension Line Stows Completed.....	WP 0011-23
Figure 25. Suspension Line Stow Completed.....	WP 0011-23
Figure 26. Riser Securing Ties Positioned.....	WP 0011-24
Figure 27. Riser Securing Ties Completed.....	WP 0011-25
Figure 28. Suspension Line Protector Flap Closed and Secured.....	WP 0011-25
Figure 29. Static Line Stowed and Secured.....	WP 0011-27
Figure 30. Parachute Pack Completed.....	WP 0011-27
Figure 31. USL Static Line Stowed and Secured.....	WP 0011-28
Figure 32. Parachute Pack Completed using USL, Breakaway..	WP 0011-28
Sewing Procedures.....	WP 0012
Table 1. Sewing Machine Code Symbols.....	WP 0012-2
Table 2. Stitching and Restitching Specifications.....	WP 0012-3
Figure 1. Machine Darning.....	WP 0012-4
Figure 2. Hand Darning.....	WP 0012-5
Figure 3. Hand Darning Completed.....	WP 0012-5
Figure 4. Straight Cut or Tear Stitching.....	0012-6
Figure 5. L-Shaped Cut or Tear Stitching.....	0012-6
Searing and Waxing.....	WP 0013
Marking and Restenciling.....	WP 0014
Bridle Loop.....	WP 0015
Figure 1. Bridle Loop Replacement Details.....	WP 0015-2

	<u>WP Sequence No.</u>
	<u>Page No.</u>
Vent Lines.....	WP 0016
Figure 1. Vent Line Replacement Details.....	WP 0016-2
Vent Reinforcement Tape (Upper Lateral Band).....	WP 0017
Figure 1. Vent Reinforcement Tape Splicing Details.....	WP 0017-3
Radial Tape.....	WP 0018
Figure 1. Radial Tape Splicing Details.....	WP 0018-2
Vertical Tape.....	WP 0019
Figure 1. Vertical Tape Splicing Details.....	WP 0019-2
Skirt Reinforcement Tape (Lower Lateral Band).....	WP 0020
Figure 1. Skirt Reinforcement Tape Splicing Details.....	WP 0020-2
Pocket Band.....	WP 0021
Figure 1. Pocket Band Replacement Details.....	WP 0021-2
Suspension Line Attaching Loop.....	WP 0022
Suspension Line.....	WP 0023
Figure 1. Suspension Line Splicing Details.....	WP 0023-2
Riser.....	WP 0024
Figure 1. Retaping Attaching Loops.....	WP 0024-2
Figure 2. Riser Splicing Details.....	WP 0024-2
Figure 3. Riser Suspension Line Attaching Loops Construction Details.....	WP 0024-3
Figure 4. Riser Assembly Construction Details.....	WP 0024-5
Deployment Bag.....	WP 0025
Deployment Bag Attaching Loop.....	WP 0026
Figure 1. Attaching Loop Fabrication Details.....	WP 0026-2
Deployment Bag Main Strap (Side and Center).....	WP 0027
Figure 1. Main Strap Splicing Details.....	WP 0027-2

	<u>Page No.</u>
Figure 2. Main Strap Construction Details.....	WP 0027-3
Figure 3. Center Main Strap Installation Details.....	WP 0027-4
Figure 4. Side Main Strap Replacement Details.....	WP 0027-6
Deployment Bag Static Line Retaining Strap.....	WP 0028
Deployment Bag Suspension Line Retaining Strap.....	WP 0029
Figure 1. Suspension Line Retaining Strap Replacement Details.....	WP 0029-2
Deployment Bag Tie Loops.....	WP 0030
Figure 1. Protector Flap Tie Loop Replacement Details.....	WP 0030-2
Deployment Bag Panels and Flaps.....	WP 0031
Figure 1. Patching Deployment Bag Panels and Flaps.....	WP 0031-2
Static Line.....	WP 0032
Figure 1. Retaping Static Line Clevis Attaching Loop.....	WP 0032-2
Figure 2. Static Line Construction Details.....	WP 0032-3
Static Line Clevis.....	WP 0033
Figure 1. Replacing Clevis Pin Retaining Cord.....	WP 0033-2
Gore Section.....	WP 0034
Figure 1. Patch Application Stitch Method.....	WP 0034-3
Figure 2. Pressure Sensitive Patch.....	WP 0034-5
Figure 3. Gore Section 1, Replacement Details.....	WP 0034-5
Figure 4. Reinstalling Pocket Band.....	WP 0034-6
Figure 5. Gore Section 2, Replacement Details.....	WP 0034-8
Figure 6. Gore Section 3, Replacement Details.....	WP 0034-9
Suspension Line Attaching Loop.....	WP 0035

	<u>Page No.</u>
Figure 1. Suspension Line Attaching Loop Replacement Details.....	WP 0035-2
Suspension Line.....	WP 0036
Figure 1. Replacement Suspension Line Construction Details.....	WP 0036-2
Figure 2. Inserting Splicing Aid into Cord Casing.....	WP 0036-2
Figure 3. Securing Suspension Line at Suspension Line Attaching Loop.....	WP 0036-3
Figure 4. Suspension Line Numerical Sequence.....	WP 0036-4
Figure 5. Securing Suspension Line at Riser Suspension Line Attaching Loop.....	WP 0036-5
Preparation for Storage or Shipment.....	WP 0037
Figure 1, A-D. Accordion Folding a Parachute Canopy Assembly.....	WP 0037-4
Figure 2. Rigger Rolling a Parachute Canopy Assembly.....	WP 0037-6
 Chapter 4 – Parts Information	
Repair Parts and Special Tools List (RPSTL), Introduction.....	WP 0038
Group 00.....	WP 0039
Figure 1. 26-foot Diameter, High-Velocity Cargo Parachute.....	WP 0039-2
Group 01.....	WP 0040
Figure 2. 26-foot Diameter, High-Velocity Cargo Parachute Canopy.....	WP 0040-2
Group 02.....	WP 0041
Figure 3. Deployment Bag.....	WP 0041-2
Group 03.....	WP 0042
Figure 4. Static Line.....	WP 0042-3
Group 04.....	WP 0043
Figure 5. Universal Static Line (USL).....	WP 0043-2

	<u>WP Sequence No.</u>
	<u>Page No.</u>
Group Bulk Materials.....	WP 0044
Special Tools List.....	WP 0045
National Stock Number Index.....	WP 0046
Part Number Index.....	WP 0047
Chapter 5 – Supporting Information	
References.....	WP 0048
Maintenance Allocation Chart (MAC).....	WP 0049
Table 1. Maintenance Allocation Chart for 26-Foot Diameter Parachute Assembly.....	WP 0049-5
Table 2. Tools and Test Equipment.....	WP 0049-7
Table 3. Remarks.....	WP 0049-8
Expendable/Durable Supplies and Materials List.....	WP 0050
Illustrated List of Manufactured Items.....	WP 0051
Figure 1. Splicing Aid Fabrication.....	WP 0051-1
Alphabetical Index	

HOW TO USE THIS MANUAL

In this manual, primary chapters appear in upper case/capital letters; work packages are presented in numeric sequence, e.g., 0001; paragraphs within a work package are not numbered and are presented in a titles format. A first level paragraph title is all upper case/capital letters, e.g., FRONT MATTER. Subordinate paragraph title will have the first letter of the first word of each principal word all upper case/capital letters, e.g., Manual Organization and Page Numbering System. The location of additional material that must be referenced is clearly marked. Illustrations supporting maintenance procedures/text are located underneath, or as close to possible to, their reference paragraph.

HOW TO OBTAIN TECHNICAL MANUALS

When a new system is introduced to the Army inventory, it is the responsibility of the receiving units to notify and inform the Unit Publications Clerk that a Technical Manual is available for the new system. Throughout the life cycle of the new system, the Distribution Center DOL-W will also provide updates and changes to the Technical Manual.

To receive new Technical Manuals or change packages to existing Technical Manuals (TM) for fielded equipment, provide the Unit Publications Clerk the full Technical Manual number, title, date of publication, and number of copies required. The Unit Publications Clerk will justify the request through the Unit Publications Officer. When the request is approved, the Unit Publications Clerk will use DA Form 12-R to order the series of Technical Manuals from the Army Publishing Directorate (APD).

Instructions for Unit Publications Clerk

Obtain DA Form 12-R and request a publications account from the APD Web site at <http://www.apd.army.mil>. Once on the Website, click on the "Orders/Subscriptions/Reports" tab. From the dropdown menu, select "Establish an Account," then select "Tutorial" and follow the instructions in the tutorial presentation.

Complete information for obtaining Army publications can be found in DA PAM 25-33.

FRONT MATTER. Front matter consists of front cover, warning summary, title block, table of contents, and How to Use this Manual page.

CHAPTER 1 – GENERAL INFORMATION. Chapter 1 contains general information and equipment.

CHAPTER 2 – MAINTENANCE INSTRUCTIONS. Chapter 2 contains service upon receipt, initial receipt, receipt of used parachute assembly, and preventive maintenance checks and service information and instructions.

CHAPTER 3 – SERVICE MAINTENANCE INSTRUCTIONS. Chapter 3 contains maintenance procedures authorized at the service level.

CHAPTER 4 – PARTS INFORMATION. Chapter 4 contains the Repair Parts and Special Tools List (RPSTL), bulk materials, special tools list, national stock number index, and part number index.

CHAPTER 5 – SUPPORTING INFORMATION. Chapter 5 contains references, expendable and durable items list, maintenance allocation chart, and illustrated list of manufactured items.

REAR MATTER. Rear matter consists of alphabetical index, DA Form 2028, authentication page, and back cover.

Manual Organization and Page Numbering System. The manual is divided into five major chapters that

detail the topics mentioned above. Within each chapter are work packages covering a wide range of topics. Each work package is numbered sequentially starting at page 1. The work package has its own page-numbering scheme and is independent of the page numbering used by other work packages. Each page of a work package has a page number of the form, XXXX YY, where XXXX is the work package number (e.g., 0010 is work package 10), and YY is the revision number for that work package. A page number such as 0010 00-1/2 Blank means that page 1 contains information but page 2 of that work package has been intentionally left blank.

Finding Information. The table of contents permits the reader to find information in the manual quickly. The reader should start here first when looking for a specific topic. The table of contents lists the topics contained within each chapter and the work package sequence number where it can be found.

Example: If the reader were looking for instructions on Splicing Radial Tape, which is a unit maintenance topic, the table of contents indicates that the unit maintenance information can be found in Chapter 3. Scanning down the listings for Chapter 3, Radial Tape information can be found in WP 0018 (Work Package 18).

An Alphabetical Index can be found at the back of the manual; specific topics are listed with the corresponding work package number.

CHAPTER 1

**GENERAL INFORMATION,
EQUIPMENT DESCRIPTION AND
THEORY OF OPERATION
FOR
PARACHUTE, CARGO TYPE:
26-FOOT DIAMETER, HIGH-VELOCITY**

**26-FOOT DIAMETER, HIGH-VELOCITY, CARGO PARACHUTE ASSEMBLY
GENERAL INFORMATION**

SCOPE

This Technical Manual provides Service and Field maintenance instructions for parachute, NSN 1670-00-872-6109. This is a 26-Foot Diameter High-Velocity Cargo Parachute. This manual also provides a Repair Parts and Special Tools List, located in WP 0039 through WP 0044.

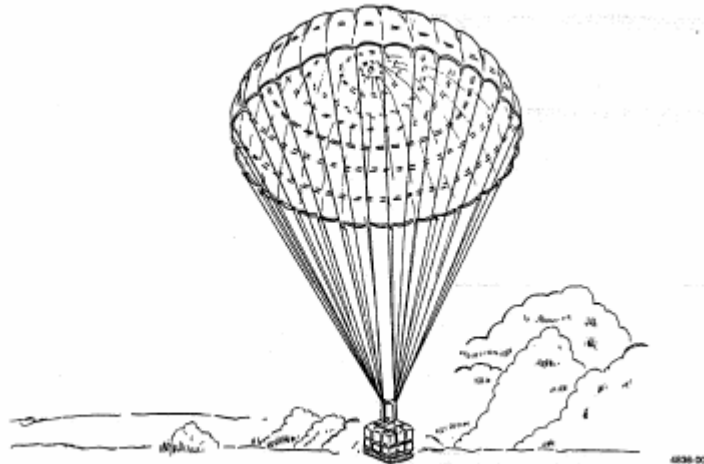

Figure 1. 26-Foot Diameter Cargo Parachute.

Equipment Name

26-Foot Diameter High-Velocity Cargo Parachute, hereinafter called the 26-Foot Cargo Parachute.

Purpose of Equipment

The parachute provides high velocity air delivery of non-fragile supplies.

MAINTENANCE FORMS, RECORDS, AND REPORTS

Department of the Army forms and procedures used for equipment maintenance will be those prescribed by DA PAM 750-8, The Army Maintenance Management System (TAMMS) users manual and TB 750-126, Use of Material Condition Tags and Labels on Army Aeronautical and Air Delivery Equipment.

REPORTING EQUIPMENT IMPROVEMENT RECOMMENDATIONS (EIR)

If your 26-Foot Cargo Parachute needs improvement, let us know. Send us an EIR. You, the user, are the only one who can tell us what you don't like about your equipment. Let us know why you don't like the design or performance. If you have Internet access, the easiest and fastest way to report problems or suggestions is to go to <https://aeeps.ria.army.mil/aeepspublic.cfm> (scroll down and choose "Submit Quality Deficiency Report" bar). The Internet form lets you choose to submit an Equipment Improvement Recommendation (EIR), a Product Quality Deficiency Report (PQDR) or a Warranty Claim Action (WCA). You may also submit your information using an SF 368 (Product Quality Deficiency Report). You can send your SF 368 via e-mail, regular mail, or facsimile using the addresses/facsimile numbers specified in DA PAM 750-8, The Army Maintenance Management System (TAMMS) Users Manual. We will send you a reply.

CORROSION PREVENTION AND CONTROL (CPC)

Corrosion Prevention and Control (CPC) of Army materiel is a continuing concern. It is important that any corrosion problems with this item be reported so that the problem can be corrected and improvements can be made to prevent the problem in future items.

While corrosion is typically associated with rusting of metals, it can also include deterioration of other materials, such as rubber and plastic. Unusual cracking, softening, swelling, or breaking of these materials may be a corrosion problem.

If a corrosion problem is identified, it can be reported using Standard Form SF 368, Product Quality Deficiency Report. Use of keywords such as "corrosion," "rust," "deterioration," or "cracking" will ensure that the information is identified as a CPC problem.

The form should be submitted to the address specified in DA PAM 750-8, Functional Users Manual for the Army Maintenance Management System (TAMMS).

PREPARATION FOR STORAGE AND SHIPMENT

For storage and shipment, refer to TM 10-1670-201-23/T.O. 13C-1-41/NAVAIR 13-1-17, and WP 0037 of this manual.

DESTRUCTION OF ARMY MATERIEL TO PREVENT ENEMY USE

GENERAL INFORMATION:

Objective

Methods of destruction used to inflict damage on air delivery equipment should make it impossible to restore equipment to a usable-condition in a combat zone, by either repair or cannibalization.

Authority

Destruction of air delivery equipment that is in imminent danger of capture by an enemy is a command decision that must be made by a battalion or higher commander, or the equivalent.

Implementation Plan

All units that possess air delivery equipment should have a plan for the implementation of destruction procedures.

Training

All personnel, who use or perform such functions as rigging, packing, maintenance, or storage of air delivery equipment, should receive thorough training on air delivery equipment destruction procedures and methods. The destruction methods demonstrated during training should be simulated. Upon completion of training, all applicable personnel should be thoroughly familiar with air delivery equipment destruction methods and be capable of performing destruction without immediate reference to any publication.

SPECIFIC METHODS

Specific methods of destroying Army materiel to prevent enemy use shall be by mechanical means, fire, or by use of natural surroundings.

Destruction by Mechanical Means

Air delivery equipment metal assemblies, parts, and packing aids shall be destroyed using hammers, bolt cutters, files, hacksaws, drills, screwdrivers, crowbars, or other similar devices used to smash, break, bend, or cut.

WARNING

Exercise extreme care when using petroleum products to destroy equipment by fire, as these materials are highly flammable. Improper handling may cause injury to personnel.

Destruction by Fire

Items that can be destroyed by fire shall be burned. The destruction of equipment by use of fire is an effective method of destroying low-melting-point metal items (e.g., side rails, threaded portions of nuts and bolts, and platforms). However, mechanical destruction should be completed first, whenever possible, before initiating destruction by fire. When items to be destroyed are made of metal, textile materials (or some comparable low combustible material) should be packed under and around the items, then soaked with a flammable petroleum product and ignited. Proper concentration of equipment, that is suitable for burning, will provide a hotter and more destructive fire.

Destruction by Use of Natural Surroundings

Small vital parts of assemblies, that are easily accessible, may be disposed of as follows: Disposal or denial of equipment to an enemy may be accomplished through use of natural surroundings. Accessible vital parts of assemblies may be removed and scattered through dense foliage, buried in dirt or sand, or thrown into a lake, stream, or other body of water. Total submersion of equipment in a body of water will provide water damage as well as concealment. Salt water will inflict extensive damage to air delivery equipment.

NOMENCLATURE CROSS-REFERENCE LIST

Common Name

Official Nomenclature

26-Foot HV
USL

26-Foot Diameter, High-Velocity Cargo Parachute Assembly
Universal Static Line

LIST OF ACRONYMS AND ABBREVIATIONS

AMC	Army Materiel Command
AR	Army Regulation
ASB	Aviation Support Battalion
BE	Bale
BER	Beyond Economic Repair
BOI	Basis of Issue
BX	Box
CAGEC	Commercial and Government Entity Code
Cm.	Centimeter
CN	Can
CO	Container
CPC	Corrosion Prevention and Control
C/W	Complied With
DA	Department of the Army
DA PAM	Department of the Army Pamphlet
DZ	Dozen
EA	Each
e.g.	For Example
EIR	Equipment Improvement Recommendation
EMP	Electromagnetic Pulse
F	Fahrenheit
FGC	Function Group Code
FIG.	Figure
FM	Field Manual
FSCM	Federal Supply Code for Manufacturer
FSC	Federal Supply Classification
ft.	Feet
GL	Gallon
GPM	Ground Precautionary Message
IAW	In accordance with
lbs	Pounds
in.	Inches
IN	Initial
INSP	Inspected
IP	In-Progress
LB	Pound
MAC	Maintenance Allocation Chart
MAM	Maintenance Advisory Message
MWO	Modification Work Order
MO	Month
MOS	Military Occupational Specialty
MTOE	Modified Table of Organization and Equipment
NAT	Natural
NCOIC	Non-Commissioned Officer in Charge
NF	National Fine (Thread)
NHA	Next Higher Assembly
NIIN	National Item Identification Number
NMP	National Maintenance Point
No.	Number
NSN	National Stock Number
OD	Olive Drab
oz.	Ounces
PAM	Pamphlet
pgs	Pages

LIST OF ACRONYMS AND ABBREVIATIONS- continued.

PMCS	Preventive Maintenance Checks and Services
P/N	Part Number
PQDR	Product Quality Deficiency Report
psi	Pounds per square inch
PT	Pint
QTY	Quantity
RO	Roll
RPSTL	Repair Parts and Special Tools List
SF	Standard Form
SH	Sheeting
SL	Spool
SMR	Source, Maintenance and Recoverability
SOUM	Safety-of-Use Message
SRA	Specialized Repair Activity
TAMMS	The Army Maintenance Management System
TASMG	
TB	Technical Bulletin
TM	Technical Manual
TMDE	Test, Measurement, and Diagnostic Equipment
T.O	Technical Order
TU	Tube
UOC	Usable on Code
UOM	Unit of Measure
USL	Universal Static Line
UUT	Unit Under Test
WP	Work Package
YD	Yard
YR	Year

Common termOfficial name

Bridle Loop	Vent Loop
Upper Lateral Band	Vent Reinforcement Tape
Lower Lateral Band	Hem/Hem Reinforcement Tape

SAFETY, CARE AND HANDLING

The following subparagraphs summarize the safety, care, and handling requirements for the parachute assembly.

Safety

Use care in handling packed parachutes, as exposed metal parts could cause painful injury.

Care and Handling

Every effort shall be made to protect the parachute from weather elements, dust, dirt, oil, grease, and acid. An unpacked parachute shall be placed in an aviator kit bag. When available, an environmentally controlled building should be used to store parachutes. Parachutes shall be stored in a dry, well-ventilated location and protected from pilferage, dampness, fire, dirt, insects, rodents, and direct sunlight. For details, refer to WP 37.

COMMON TOOLS AND EQUIPMENT

For authorized common tools and equipment, refer to the Modified Table of Organization and Equipment (MTOE) applicable to your unit.

SPECIAL TOOLS, TEST MEASUREMENT AND DIAGNOSTIC EQUIPMENT (TMDE), AND SUPPORT EQUIPMENT

Special tools, TMDE and support equipment are not required.

REPAIR PARTS AND SPECIAL TOOLS LIST (RPSTL)

Repair parts are listed and illustrated in WP 0039 through WP 0044 of this manual.

**CHAPTER 2
MAINTENANCE INSTRUCTIONS
FOR
PARACHUTE, CARGO TYPE:
26-FOOT DIAMETER, HIGH-VELOCITY**

**26-FOOT DIAMETER, HIGH-VELOCITY, CARGO PARACHUTE ASSEMBLY
EQUIPMENT DESCRIPTION AND DATA**

EQUIPMENT CHARACTERISTICS, CAPABILITIES AND FEATURES

Characteristics

Provides a capability to vertically deliver cargo weighing up to 2200 lbs., to support troops fighting on the ground.

Capabilities and Features

- Increased accuracy
- Capable of supporting up to 2200 lbs.
- Low cost
- Designed for decelerating and stabilizing high-velocity air delivery cargo
- Complete assembly weight: 22 lbs.
- Components of the assembly: canopy assembly, deployment bag, static line.

LOCATION AND DESCRIPTION OF MAJOR COMPONENTS

Canopy

The 26-foot Diameter, High-Velocity Cargo Parachute contains a cotton cloth cargo canopy of ring-slot construction, 26 suspension lines, a riser assembly, and a clevis to attach parachute assembly to cargo bundle.

Static Line

A 15-foot $\frac{3}{4}$ inch tubular nylon webbing with a large loop formed at one end and a small formed loop and clevis at the other end. May be used in either breakaway or non-breakaway method of deployment.

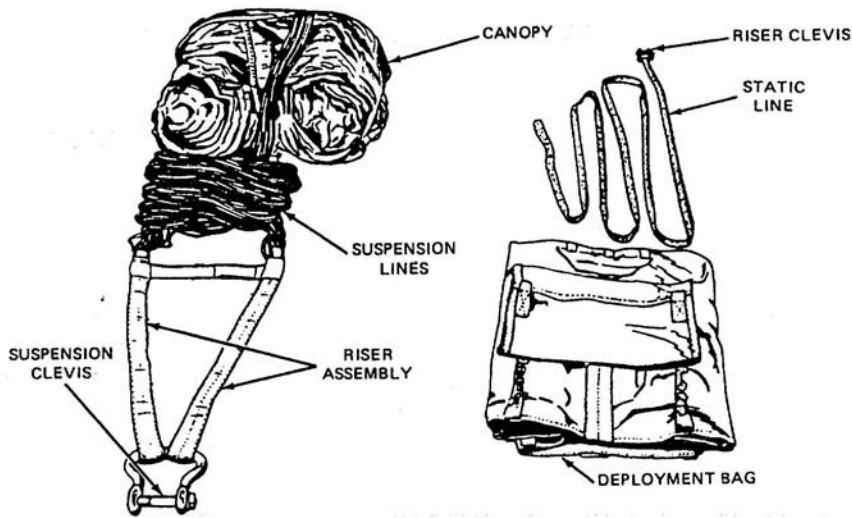

Figure 1. The 26-Foot Diameter, High-Velocity Cargo Parachute, with Deployment Bag.

Deployment Bag

The 26-Foot Diameter, High-Velocity Cargo Parachute is packed in the deployment bag. The deployment bag is constructed of a cotton cloth bag or nylon bag. These bags differ in the attachment of a static line, standard, or Universal Static Line (USL).

EQUIPMENT DATA

The following list summarizes the specific capabilities and limitations of the equipment, and other critical data, needed by the Field maintenance personnel for maintenance of the 26-Foot Diameter, High-Velocity Cargo Parachute.

Weight (packed for airdrop)	22 lbs (approx)
Dimensions (packed for use)	20 in long X 17 in wide X 10 in high

CANOPY ASSEMBLY

Shape	Flat-circular
Diameter (nominal)	26 feet
No. of gores	26
No. of sections per gore	8
Gore material	Type III, 3.5 oz. cotton muslin cloth
No. of radial tapes	26
No. of vent lines	13
Vent line material	Type II, coreless nylon cord
No. of pocket bands	26
Suspension line material	Type II, coreless nylon cord
Length of suspension line (riser suspension line attaching loop to canopy skirt)	26 feet
Length of canopy (skirt reinforcement tape to vent reinforcement tape)	142 $\frac{3}{4}$ in

RISER ASSEMBLY

Length	30 in
No. of suspension clevises used	1

DEPLOYMENT BAG

Bag length	23 $\frac{3}{4}$ in
Bag width	19 in

STATIC LINE

Length	15 ft
No. of static line clevises used	1

**26-FOOT DIAMETER, HIGH-VELOCITY CARGO PARACHUTE ASSEMBLY
SERVICE UPON RECEIPT**

INITIAL SETUP:**Tools**

Needle, Tacking (WP 0049, Item 9)
Shears (WP 0049, Item 13)

Materials/Parts

Tape lacing and tying (WP 0050, Item 27)

References

DA PAM 750-8
DA PAM 738-751
MCO 4855.10B
WP 0007
WP 0008
WP 0014
WP 0049

Personnel Required

92R1P Parachute Rigger

Equipment Condition

All equipment shall be serviceable and ready for use.

OVERVIEW

This chapter contains information necessary to maintain the 26-Foot Diameter, High-Velocity Cargo Parachute, on the Field maintenance levels, in accordance with the Maintenance Allocation Chart (MAC) for the equipment. It includes the following:

1. Procedures for processing a new or used parachute assembly upon receipt.
2. Assembly of components prior to packing.
3. Preventive maintenance procedures to ensure continued serviceability of all components.
4. As required, inspections and maintenance procedures performed prior to packing, such as shakeout and airing, and cleaning and drying, and acidity and salt-water contamination tests.
5. Detailed packing procedure.
6. Repair methods and repair, or replacement, procedures for all components of the parachute assembly.

INITIAL RECEIPT

The following describes the procedures for processing parachutes upon initial receipt.

General Procedures for Air Delivery Equipment

When air delivery equipment is initially procured from a supply source and issued to a using unit, the item(s) will be unpacked from the shipping container(s) and inspected by a qualified parachute rigger (MOS 92R). The inspection will be a technical/ rigger-type inspection and will be conducted as outlined in the Preventive Maintenance Checks and Services (PMCS) procedures. Upon completion of the inspection, the item(s) will be tagged as prescribed in DA PAM 738-751. Serviceable equipment may then be entered either into storage or into use in airdrop operations, as applicable. An unserviceable item will be held and reported in accordance with DA PAM 750-8/MCO 4855.10B.

Inspection Personnel

Personnel other than parachute rigger personnel may assist in the unpacking process of initially received parachutes, as directed by the local Airdrop Systems Technician (921A) or Senior Airdrop NCO (92R4P) and above, under guidance from an Airdrop Systems Technician assigned to the command at the Battalion level or higher, when no Airdrop Technician is assigned at the Company/Detachment/Team level. However, the entire unpacking effort must be conducted under the direct supervision of a qualified rigger (92R).

Configuration Condition

Acceptance of new equipment from the manufacturer is based upon inspections made of sample lots that have been randomly selected in accordance with military standards. It is incumbent upon the using activity personnel to bear this in mind whenever equipment is first placed in service. Changes will sometimes evolve from the original equipment design, and sometimes contractors are authorized deviations in material and construction techniques. Air delivery equipment that has been in the field cannot be expected to meet exacting manufacturing specifications; however, the equipment should closely reflect desired design characteristics. Since repairs, modifications, and/or changes can alter or detract from the configuration originally desired, such equipment shall be airworthy, safe, of the desired configuration, and adequate for intended use.

Marking Parachutes

Prior to being placed into service, personnel parachutes that have had no previous use will be marked to reflect the date of entry into service. The marking will be made on the canopy information data block by stenciling the lettering in minimum 1/2-inch characters, using the marking and restenciling repair procedures detailed in WP 0014. Other applicable parachute components will be marked adjacent to existing data. The stenciled data will appear on IN-SVC followed by the date, which will indicate the month and calendar year, such as "Jan. 05". Ensure the added marking does not infringe upon, or obliterate, any original data on the information data block.

Parachute Log Record

The Army Parachute Log Record, DA Form 3912, AFTO 391 is a history-type maintenance document that accompanies the parachute canopy and pack tray assemblies through the period of service of the individual assembly. The log record provides a means of recording maintenance actions performed on a parachute canopy assembly. Normally, a log record is initiated and attached to a riser assembly (main parachute) or pack tray (reserve parachute) upon receipt by a using unit. If the item is subjected to alteration or modification by a maintenance activity during the interim period, from date of manufacture to receipt by a using unit, the log record will be prepared by the activity performing the maintenance function. Once initiated, a log record will be attached to and contained in an affixed parachute log record/inspection data pocket, until such time as the parachute canopy assembly is destroyed or rendered unfit for further use or repair.

Additionally, should an item that requires a log record be transferred from one unit to another, the log record for the parachute assembly will accompany the item in the transfer action. A prepared log record will not be removed or separated from a parachute, especially a packed parachute, except as directed by the local air delivery equipment maintenance activity officer or aerial delivery NCOIC.

A log record that is illegible, lost, damaged, soiled, or precludes further entries due to lack of space will be replaced upon the next repack or inspection, as applicable, with a serviceable item from stock.

Installing Attaching Tie

Install attaching tie as follows:

1. Cut a 30-inch length of tape, lacing and tying (super tack) and double the lacing length.
2. Pass the looped end, of the doubled lacing length, around the centerfold of the log record and form a slip loop on the outside, at the log record top.

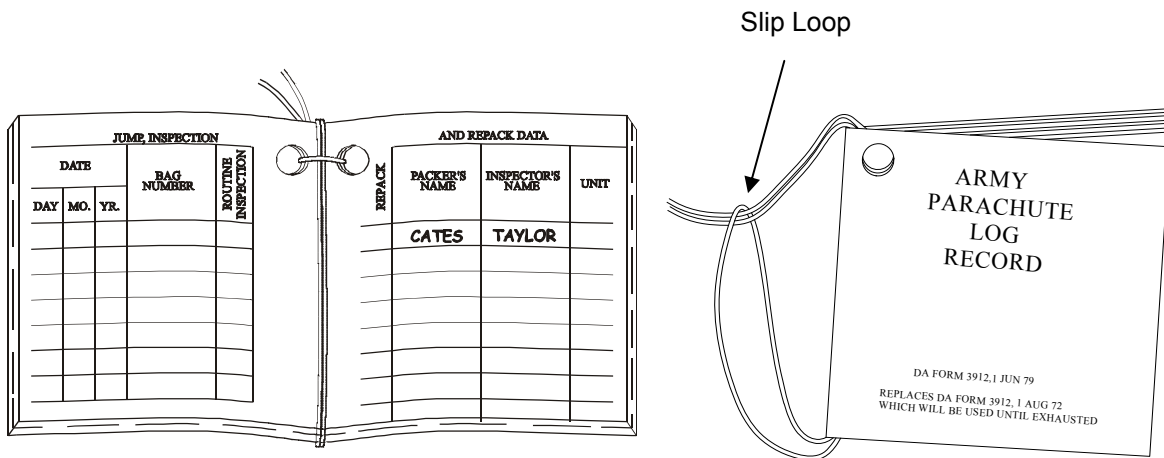

Routing Lacing Loose End Through Log Record Centerfold

Forming Slip Loop On Log Record Outside

Figure 1. Installing Attaching Tie.

3. Pass the lacing length running ends through the corner attaching hole, from the front to rear of the log record.

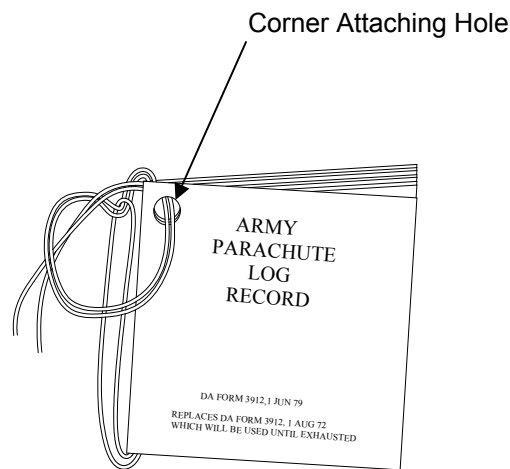

Passing Lacing Loose Ends Through Corner Attaching Hole

Figure 2. Corner Attaching Hole.

4. Ensure the running ends are routed over that part of the lacing length located along the log record centerfold.
5. Complete the attachment tie by making a half hitch on top of the slip loop made in step 2, above.
6. Thread one running end of the log record attachment tie in a tacking needle and pass the tacking needle, with attached end, through the edge binding of the applicable parachute log record/inspection data pocket.
7. Remove the lacing end from the tacking needle; make a finished 10-inch long log record attaching loop by securing the two lacing ends together with an overhand knot.

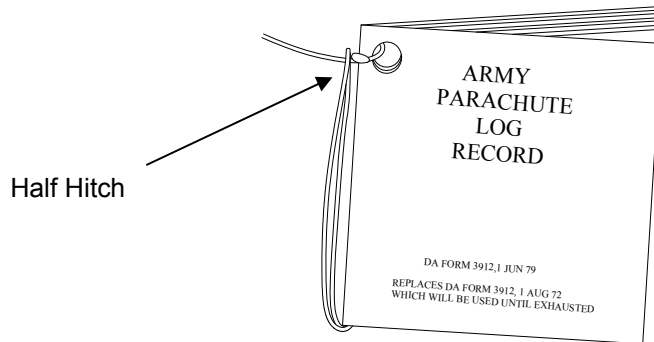

Figure 3. Log Record Attachment Tie Completed.

8. Insert the log record into the pocket, and secure the record within the pocket using the pocket flap and applicable flap fastener.

END OF TASK

Accomplishing a Log Record

Upon completion of the first rigger-type technical/ inspection, the individual performing the inspection will initially prepare a log record for an individual parachute, or applicable type parachute harness, and accomplish subsequent record entries using the following procedures:

NOTE

Log record book entries will be made with a suitable type blue or black marking device that cannot be erased (no felt tip markers).

1. Inside Front Cover. Using the information provided on the parachute canopy data block, make the following entries on the inside front cover of the log record. Entries may be continued on the inside of the back cover, if necessary.

SERIAL NO.	<input type="text"/>
TYPE	<input type="text"/>
PART NO.	<input type="text"/>
DATE OF MFG. (Month & Year)	<input type="text"/>
MANUFACTURER	<input type="text"/>
CANOPY CONTRACT NO.	<input type="text"/>
MO/YR CANOPY PLACED IN SERVICE	<input type="text"/>
STATION & UNIT	<input type="text"/>
	<input type="text"/>
	<input type="text"/>
(Continued on inside back cover)	

Figure 4. Log Record Form.

NOTE

A parachute canopy serial number is recorded in a log record as a method of establishing control for maintenance, Equipment Improvement Report (EIR) and Product Quality Deficiency Report (PQDR) documentation, and to ensure the correct original record is reattached should the record become detached. A canopy serial number will not be used for property accountability, except in test projects or other special instances.

- a. Serial Number. Enter the parachute canopy assembly serial number.
 - b. Type. Enter the parachute type.
 - c. Part number. Enter the part number of the parachute canopy.
 - d. Date of Manufacture. Enter the month and year the parachute canopy was manufactured.
 - e. Manufacturer. Enter the name of the parachute canopy manufacturer.
 - f. Canopy Contract Number. Enter the entire contract number specified for the parachute canopy.
 - g. MO/YR Canopy Placed in Service. Enter the month and year parachute canopy is placed into service.
 - h. Station and Unit. Enter the name of the station and unit to which the parachute canopy is currently assigned. When a parachute is transferred permanently to another station, and/or unit, the original entry will be lined out and the name of the receiving station, and/or unit, will be entered.
2. Inside Back Cover. Entries may be continued on the inside back cover, if necessary.

- d. Inspected by. The individual who accomplished the inspection, required after modification, will sign this entry with last name only.
- e. Unit. Enter the unit designation responsible for performing the MWO or, in the event of a lost log record, the unit to which the inspector is assigned.
- f. Date. Enter the day, month, and year the modification work was completed.

4. Service and Field Maintenance Repair and Inspection Data. When a parachute canopy assembly is initially received from a supply source, and a technical/rigger-type inspection is performed, the inspection accomplishment will be documented on the Unit and Intermediate Repair and Inspection Data page of the individual parachute log record. Additional entries will also be made on this page each time the canopy assembly is repaired, or is administered an inspection, in compliance with a Safety-of-Use-Message (SOUM), Ground Precautionary Message (GPM), or a Maintenance Advisory Message (MAM). The page completion criteria are as follows:

- a. Type of repair. Enter the type of repair, completion of initial inspection, repair accomplishment, SOUM, GPM, or MAM inspection compliance.
- b. Inspection by. The individual, who accomplished the inspection required, will sign this entry with last name.
- c. Unit. Enter the unit designation responsible for performing the type of repair.
- d. Date. Enter the day, month, and year the repair was performed.

UNIT & INTERMEDIATE	REPAIR & INSPECTION DATA				
TYPE OF REPAIR Initial Inspection ISEC and 4 lines replaced TB 10-1670-213-2015	INSP BY Phillips Kididis Land	UNIT SBCCOM SBCCOM SBCCOM	DATE DAY MONTH YEAR		
			12	2	01
			3	3	01
			10	4	01

1. Completion Of Initial Inspection.
2. Repair Accomplishment.
3. Technical Bulletin Inspection compliance.

Figure 7. Note Page.

- e. Notes page. A page is provided at the back of a parachute log record to accommodate recording additional data pertinent to the serviceability of a parachute canopy assembly. This shall also include the month and year the risers were placed in service.

NOTE

A parachute log record that is completely filled out, lost, illegible, or in an otherwise unserviceable condition, will be replaced with a serviceable log record.

5. Replacing a filled out or unserviceable log record.
 - a. Using a suitable blue or black marking device, enter "NEW BOOK" on the outside front cover of the replacement log record.
 - b. Transcribe the information from the inside front cover of the original log record to the inside front cover of the replacement log record. If the original data is illegible or missing, use the canopy information data block to collect the required data.
 - c. In the replacement log, record transcribe the initial and last entry made on the Jump, Inspection, and Repack Data page of the original log record.
 - d. Transcribe all data from the remaining pages of the original log record to the appropriate pages of the replacement log record.
 - e. After all original data has been transcribed, destroy the original log record.
6. Replacing a lost log record.

NOTE

Any time a log record is discovered missing from a parachute, a replacement log record will be initiated during repack or inspection, as applicable.

- a. Accomplish the log record inside front cover as prescribed above.
- b. If it can be ascertained by inspection that a previous MWO, SOUM, GPM, or MAM has been complied with, applicable entries will be made on the appropriate page of the replacement log record.
- c. Attach the replacement log record to the log record/inspection data pocket using the procedures above.

END OF TASK

RECEIPT OF USED PARACHUTE

Upon initial receipt of used parachute, proceed as follows:

1. Follow procedures given in the General Procedures for Air Delivery Equipment paragraph, above, and check each component for excessive wear and tear.
2. If defects or damages are discovered, process the parachute for maintenance at the maintenance level assigned by the Maintenance Allocation Chart (MAC), WP 0049.

END OF TASK**AFTER-USE RECEIPT**

When a parachute is received at the maintenance activity, following its use during airdrop, it must be given a shakeout, aired (WP 0007) and, if necessary, cleaned (WP 0008) before it can be returned to service. If a parachute is issued but is not used, it does not need to be given a shakeout; however, it must be given a routine inspection by a qualified parachute rigger (MOS 92R).

END OF TASK**END OF WORK PACKAGE**

**26-FOOT DIAMETER, HIGH-VELOCITY CARGO PARACHUTE ASSEMBLY
ASSEMBLING THE 26-FOOT DIAMETER, HIGH-VELOCITY CARGO PARACHUTE ASSEMBLY**

INITIAL SETUP:**Personnel Required**

92R1P Parachute Rigger

References**Equipment Condition**

WP 0011

Parachute canopy in proper layout on packing table or other suitable surface.

ASSEMBLY**Assembling the 26-Foot Cargo Parachute**

The procedure for assembling components of parachute is incorporated in the packing procedure, WP 0011.

END OF TASK**END OF WORK PACKAGE**

**SERVICE AND FIELD MAINTENANCE
26-FOOT DIAMETER, HIGH-VELOCITY CARGO PARACHUTE ASSEMBLY
PREVENTIVE MAINTENANCE CHECKS AND SERVICES (PMCS), INTRODUCTION**

GENERAL

The following paragraphs describe PMCS procedures for the Service maintenance support level. The purpose of PMCS is to ensure the 26-Foot Diameter, High-Velocity Cargo Parachute is in proper operating condition and ready for its primary use.

SCOPE

The scope of this work package is to provide guidance on the PMCS procedure, what to do once a fault is identified, and how to record faults.

MAINTENANCE FUNCTIONS/PROCEDURES

Each of the mentioned work packages above identifies a maintenance function specified in the MAC.

PARACHUTE REPACK INTERVAL

The 26-Foot Diameter, High-Velocity Cargo Parachute will be repacked at a scheduled interval to ensure airworthiness. When necessitated by climate/storage/use condition, the local Airdrop Systems Technician (921A) or Senior Airdrop NCO (92R4P) and above, under guidance from an Airdrop Systems Technician assigned to the command at the Battalion level or higher, when no Airdrop Technician is assigned at the Company/Detachment/Team level, may require more frequent repack intervals. In this regard, a major concern would be rapid fluctuations of temperature (fluctuations around 32 degrees Fahrenheit, freezing point), sustained high or low temperature, or high humidity and a heavily-polluted atmosphere. The 26-Foot Diameter, High-Velocity Cargo Parachute will be repacked every 365 days. However, the repack cycle of the 26-Foot Diameter, High-Velocity Cargo Parachutes stored in depots and facilities that maintain contingency stocks of 26-Foot-Diameter Parachutes, which are specifically identified as "*PACKED FOR CONTINGENCY*" and stored separately from normal parachute stock, will be repacked at a 144-month interval. This is only to occur providing the storage conditions are in accordance with this TM.

DROP-TESTING CRITERIA

Drop-testing the 26-Foot Diameter, High-Velocity Cargo Parachute consists of physically airdropping an item from an aircraft in flight. The drop-test is used as a means of proving the serviceability of an item or checking parachute rigger proficiency and will only be performed under the supervision of qualified parachute rigger personnel who satisfy the supervisory requirements outlined in AR 750-32. Drop testing will usually be conducted by an activity responsible for the inspection and maintenance of airdrop equipment, which includes either parachute packing or airdrop load rigging. The criteria required to accomplish a drop-test is as follows:

1. During the drop-test of any type parachute, the deployment of the parachute will be thoroughly monitored and observed to detect any indication of malfunction or defect. Any defect or malfunction detected in a drop-test will be annotated in the log record book using procedures outlined in WP 0003, SERVICE UPON RECEIPT.
2. Any type of airdrop equipment that indicates evidence of malfunction/defect, during or after a drop-test, will be disposed of as prescribed in WP 0009, INSPECTION.
3. Airdrop equipment that does not reflect evidence of malfunction or defect upon completion of a test-drop will be administered a technical/rigger-type inspection as outlined in WP 0009, INSPECTION. If items are deemed serviceable, the item(s) may then remain in use.

GENERAL

The following paragraphs describe PMCS procedures for the service maintenance level. Table 1 has been provided to ensure the 26-Foot Diameter, High-Velocity Cargo Parachute is in proper operating condition and ready for its primary mission.

Warnings and Cautions

Warnings and cautions appear before applicable procedures. You must observe these warnings and cautions to prevent serious injury to yourself and others and to prevent damage to equipment.

Frequency of Performing PMCS

PMCS will be performed before equipment is packed for use, during modification and repair, after use, or at any time deemed necessary by the air delivery equipment maintenance supervisor.

PMCS Table Column Entries

Enter data in the columns as follows:

- Item number. Item number required for the TM number column on DA Form 2404 (Equipment Inspection and Maintenance Worksheet) when recording the results of PMCS.
- Interval. Required PMCS level.
- Item to be inspected. Common name of the item to be inspected.
- Procedures. Brief description of the procedure by which the checks are to be performed.

Recording Defects

All defects discovered during the inspection will be recorded using the applicable specifics in DA PAM 750-8, DA PAM 738-751, and TB 43-0002-43.

Conservation of Resources

To conserve time and labor, and to avoid evacuation to an intermediate maintenance activity, unit/detachment commanders may designate, in writing, rigger personnel to accomplish classification inspection of overage air delivery equipment. The 26-Foot Diameter High-Velocity Cargo Parachute has no age or service life.

Inspection Function Requirement

Normally, airdrop equipment maintenance personnel at a packing, rigging, or repair activity will perform a technical/rigger-type inspection. The inspection of initial receipt items will be performed as a separate function from packing or rigging activity; the item to be inspected will be placed in proper layout on a packing surface or suitably-sized floor area.

Should any defect or damage be discovered at any point during the inspection, the inspection will be terminated, and the applicable item will be processed and forwarded to the repair activity. The repair activity, in turn, will conduct a technical/rigger-type inspection that will be performed by only those parachute rigger personnel cited in AR 750-32.

Any defect discovered during a service level repair activity inspection, that exceeds the capability of that activity, will require the affected item to be evacuated to a field maintenance function for further determination of economic repair and repair accomplishment, if applicable.

NOTE

Parachutes that are deemed unserviceable by a packing or rigging activity will be rigger-rolled in accordance with WP 0037, PREPARATION FOR STORAGE OR SHIPMENT (Accordion Folding/Rigger Rolling), prior to being sent to a repair activity.

Table 1. Preventive Maintenance Checks and Services (PMCS).

ITEM NO.	INTERVAL	ITEM TO BE CHECKED OR SERVICED	PROCEDURE	EQUIPMENT NOT READY/AVAILABLE IF:
00	Before & After	The 26-Foot Diameter, High-Velocity Cargo Parachute	Verify that assembly is complete and no components are missing. Check for proper assembly, foreign material, mildew or stains, and log record book.	Assembly is incomplete or improperly assembled, is missing components or log book, has foreign material, mildew or stains.
01	Before	Parachute (Packed for Use)	Visually check visible parts for serviceability and completeness without opening pack. Check parachute inspection data record for pack date.	Visible parts appear unserviceable or incomplete, or inspection/pack date is out of acceptable range.
02	Before & After	Canopy	<p>As canopy is raised, suspended, and lowered during shakeout, check for dampness, mildew, acid, grease, oil, dirt, foreign material, holes, cuts, tears; broken lines, and webbing.</p> <p>Fabric Material. Legibility of marking data; completeness; dampness, mildew, dirt, acid, grease, oil, foreign material, rips, burns, cuts, breaks, frays, tears, holes, thin spots, loose weaving; loose or broken stitching, lines, and webbing.</p> <p>Hardware Components. Corrosion, rough spots, burrs, breaks, cracks, bends; loose or missing screws.</p>	<p>Shakeout reveals dampness, mildew, acid, grease, oil, dirt, foreign material, holes, cuts, tears; broken lines, and webbing.</p> <p>Marking data illegible or incomplete; fabric shows dampness, mildew, dirt, acid, grease, oil, foreign material, rips, burns, cuts, breaks, frays, tears, holes, thin spots, loose weaving; loose or broken stitching, lines, and webbing.</p> <p>Hardware has corrosion, rough spots, burrs, breaks, cracks, bends; loose or missing screws.</p>
03	Before & After	Deployment Bag and Static Line	<p>Completeness, dampness, mildew, acid, grease, oil, dirt, foreign material, holes, cuts, and breaks.</p> <p>Fabric Material. Completeness; dampness, mildew, dirt, acid, grease, oil, foreign material, rips, burns, cuts, breaks, frays, tears, holes; loose or broken stitching.</p> <p>Hardware Components. Corrosion, rough spots, burrs, breaks, cracks, bends; loose or missing grommets.</p>	<p>Deployment bag/static line are incomplete, or show signs of dampness, mildew, acid, grease, oil, dirt, foreign material, holes, cuts, and breaks.</p> <p>Fabric is incomplete, or shows signs of dampness, mildew, dirt, acid, grease, oil, foreign material, rips, burns, cuts, breaks, frays, tears, holes; loose or broken stitching.</p> <p>Hardware has corrosion, rough spots, burrs, breaks, cracks, bends; loose or missing grommets.</p>

LUBRICATION SERVICE INTERVALS

The 26-Foot Diameter, High-Velocity Cargo Parachute does not require lubrication service.

END OF TASK

END OF WORK PACKAGE

CHAPTER 3

SERVICE MAINTENANCE INSTRUCTIONS
FOR
PARACHUTE, CARGO TYPE:
26-FOOT DIAMETER, HIGH-VELOCITY

SERVICE MAINTENANCE
26-FOOT DIAMETER, HIGH-VELOCITY CARGO PARACHUTE ASSEMBLY
SHAKEOUT AND AIRING

INITIAL SETUP:**Tools**

Brush, Scrub, Household (WP 0049, Item 1)

Personnel Required

Two

Equipment Condition

Parachute Suspended

SHAKEOUT

A two-person team, either indoors within a shakeout room or outdoors at a shakeout tower, will accomplish the shakeout. Each parachute will be suspended by the canopy bridle loop and all debris removed by shaking the canopy thoroughly or by brushing with a dry, soft-bristled brush, as detailed below:

1. With assistance from the No. 2 person, the No. 1 person will connect the snap on a pulley rope to the canopy bridle loop.

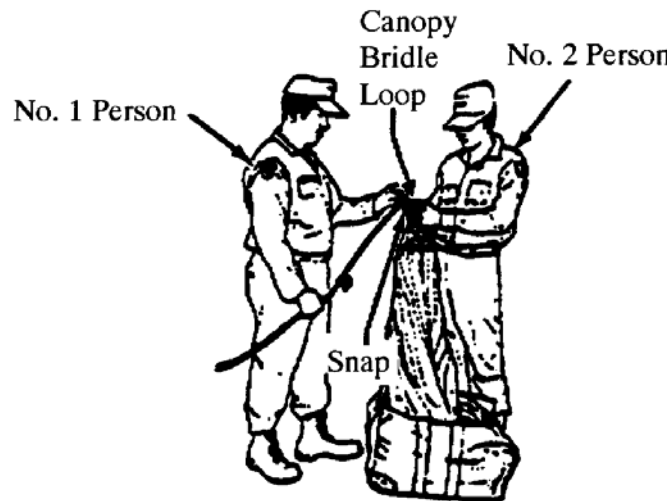

Figure 1. Attaching Rope to Canopy.

2. Through use of the pulley rope, the No. 2 person will raise the canopy to a suitable height; this will enable the No. 1 person to perform shakeout on each of the canopy gores. Until the gore shaking process is completed, the No. 2 person will maintain a steady pull on the pulley rope to hold the suspended canopy at the working height needed by the No. 1 person.

3. The No. 1 person will grasp any two-consecutive suspension lines, one in each hand, and vigorously shake the first gore. When the gore is free of debris, the No. 1 person passes the line from the right hand to the left hand and grasps the next consecutive suspension line in the right hand. The No. 1 person will shake out each consecutive gore until all suspension lines are held in the left hand and all gores are free of debris.

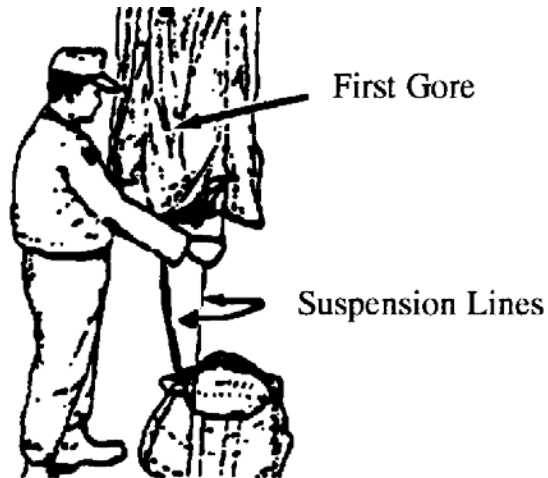

Figure 2. First Gore.

4. Once the gore shaking process is completed, the No. 2 person will slowly raise the suspended canopy higher as the No. 1 person clears the suspension lines of debris and removes entanglements, when possible.

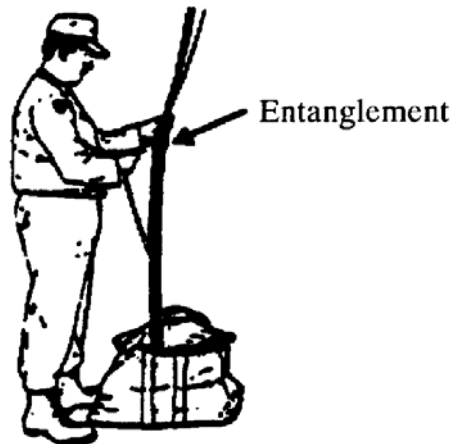

Figure 3. Entanglement.

5. After the suspension lines have been cleared, the No. 2 person may hold, or temporarily secure, the pulley rope while the No. 1 person proceeds to clear debris from other parachute components such as the risers, harness, and pack tray. When all components are free of debris, the No. 2 person will slowly lower the canopy, while the No. 1 person S-folds the suspension lines into a suitably-sized container. After the suspension lines have been completely folded, the No. 1 person will accordion-fold the canopy length on top of the folded lines.

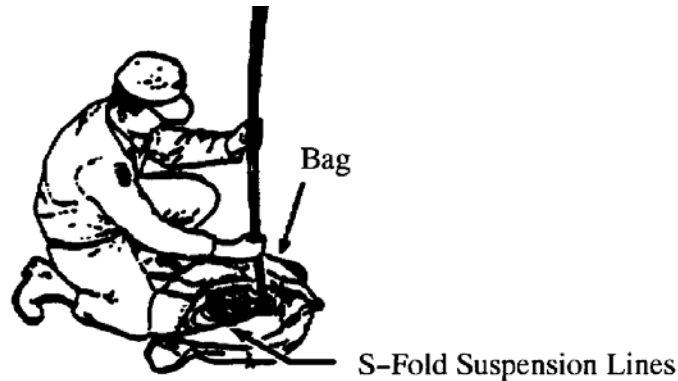

Figure 4. S-Fold Suspension Lines.

6. As the canopy folding is being completed, the No. 1 person disconnects the canopy vent from the pulley rope snap. Secure the folded canopy assembly for further handling.

END OF TASK

AIRING

Where dampness and mildew are prevalent, air delivery equipment will be aired at frequent intervals according to the severity of the prevailing conditions. Parachutes that have been previously packed or are unpacked, and have been subjected to conditions of dampness or mildew, will be aired for a period of at least 6 hours prior to being repacked. Air delivery items may be aired either indoors or outdoors, in dry weather. However, fabric items will not be aired in direct sunlight. Airing may be accomplished by suspending or elevating the applicable item(s) in a manner that would allow maximum exposure to air circulation. Outside facilities used for the shakeout of parachutes may be used for the airing of air delivery equipment, if weather conditions permit. If the shakeout facilities are inadequate for airing, the applicable item(s) may be suspended or elevated at several points, or draped over suitable type objects that will not cause damage.

END OF TASK

END OF WORK PACKAGE

SERVICE MAINTENANCE
26-FOOT DIAMETER, HIGH-VELOCITY CARGO PARACHUTE ASSEMBLY
CLEANING AND DRYING

INITIAL SETUP:**Tools**

Brush, Scrub Household (WP 0049, Item 1)

Materials/Parts

Cloth, Abrasive (WP 0050, Item 6)
 Dishwashing Compound (WP 0050, Item 15)
 Lubricant, Solid Film (WP 0050, Item 17)
 Rag, Wiping (WP 0050, Item 24)
 Cleaning, Compound (WP 0050, Item 5)

References

WP 0003
 WP 0039
 WP 0049

Personnel Required

92R1P Parachute Rigger

Equipment Condition

Laid out on packing table or other suitable surface.

WARNING

Due to flammable properties and nylon-damaging substances, cleaning solvents, other than EVERBLUM GOLD™ (industrial cleaner), will not be used in the spot-cleaning of airdrop equipment. EVERBLUM GOLD™ will only be used in areas where substantial ventilation is available. Repeated or prolonged inhalation of the solvent vapors can be detrimental to human health. In addition, avoid prolonged or repeated skin contact with the solvent fluid. EVERBLUM GOLD™ must not be taken internally.

CAUTION

If, during the cleaning, there exists a possibility that the substance to be removed contains acid or some other equally destructive ingredient, the item will be evacuated to intermediate maintenance activity for determination as to the nature of the substance and item disposition. If the substance cannot be identified, or if normal repair procedures will not eliminate all traces of chemical or acid damage, the applicable item will be condemned.

CAUTION

Do not use EVERBLUM GOLD™ on polyester.

NOTE

Cleaning of parachutes should be held to a minimum and should be performed only when necessary, to prevent malfunction or deterioration. When a parachute contains debris, or when it is soiled by dirt, oil, grease, rust, corrosion, or other foreign substances, to such an extent that cleaning is necessary, the cleaning should be performed manually and should be limited to the soiled area only, unless the parachute has been contaminated by water. The methods of cleaning must be determined by the nature of the substance to be removed. Do not use cleaning solvent to clean items soiled by airsickness. Use a solution of hand dishwashing compound to clean this type of soiling.

CLEANING FABRIC ITEMS WITH A SOLUTION OF HAND DISHWASHING COMPOUND

Use dishwashing compound to clean fabric items as follows:

1. Gently brush with a soft bristle brush.
2. Spot clean with a solution of dishwashing compound.
 - a. Dissolve one-half cup of dishwashing compound in one gallon of warm water.
 - b. Rub the soiled area with a clean cloth dampened with a solution of dishwashing compound.
 - c. Rinse the cleaned area by repeating the rubbing process, with a clean portion of the cloth dampened with water.

END OF TASK

RINSING PARACHUTE ASSEMBLY IMMERSSED IN SALT WATER

If the parachute, or any of its components, has been immersed in salt water in excess of 24 hours, it will be condemned. Additionally, if the parachute, or any of its components, has been immersed in salt water for a period less than 24 hours, but cannot be rinsed within 48 hours after recovery, it will also be condemned. However, if the cited time limitations can be met, then immediately, upon recovery, suspend or elevate the parachute assembly in a shaded area and allow it to drain for at least 5 minutes. Do not attempt to wring the fabric or the suspension lines. Within 48 hours after recovery, under the supervision of a qualified parachute rigger (92R1P), rinse the recovered parachute assembly as follows:

1. Place the parachute assembly in a large, watertight container filled with a suitable amount of fresh, clean water to cover the assembly.

NOTE

If the salt-water-soaked parachute assembly is too large to be placed into a rinsing container, then the rinsing process will be affected by applying fresh, clean water to the assembly using a hose.

2. Agitate the container contents by hand for 5 minutes.

3. Remove the parachute assembly from the container and suspend or elevate it in a shaded area, allowing a 5-minute drainage period. Do not attempt to wring the fabric or the suspension lines.
4. Repeat the procedures in steps 1 through 3 above, twice, using fresh, clean water for each rinse.
5. After the third rinse, allow the parachute assembly to drain thoroughly. Upon completion of draining, dry the assembly in accordance with the "DRYING FABRIC ITEMS" procedures below.
6. When dried, perform a technical/rigger-type inspection of the parachute assembly. Corroded metal components, or corrosion-stained fabrics or suspension lines, will be either repaired or replaced as prescribed by the Maintenance Allocation Chart (MAC) in WP 0049.
7. Record any repair, immersion, and rinsing in the parachute log record as shown on the "Notes" page in WP 0003.

END OF TASK

RINSING PARACHUTE ASSEMBLY IMMERSSED IN FRESH WATER

Any parachute, or its components, that has been immersed in a fresh-water lake, river, or stream will not require rinsing unless it has been ascertained that the water is dirty, oily, or otherwise contaminated. Procedures for handling a fresh-water immersed parachute are as follows:

1. Uncontaminated fresh water. If the parachute, or its components, has been immersed in uncontaminated fresh water, rinse and dry and, if applicable, repair.
2. Contaminated fresh-water. If the parachute, or its components, has been immersed in contaminated fresh-water, it will be cleaned and dried as outlined in "CLEANING FABRIC ITEMS WITH A SOLUTION OF HAND DISHWASHING COMPOUND," "DRYING FABRIC ITEMS," and "CLEANING METAL ITEMS," in the detailed paragraphs above and below. Minor discoloration of fabric items, resulting from immersion in contaminated fresh water, may occur.

END OF TASK

NOTE

Fabric items will not be dried in direct sunlight or by laying an item on the ground.

DRYING FABRIC ITEMS

Dry fabric items as follows:

1. Suspend or elevate the item in a well-ventilated room or in a heated drying room.
2. Using electric circulating fans may reduce drying time.
3. When heat is used, the heat temperature shall not exceed 160 degrees Fahrenheit (71 degrees Celsius). The preferred temperature is 140 degrees Fahrenheit (60 degrees Celsius).

END OF TASK

CLEANING METAL ITEMS

Clean metal items as follows:

CAUTION

Use care not to damage the adjacent fabric materials.

1. Remove burrs, rough spots, rust, or corrosion from metal items by filing with a metal file or by buffing and polishing with abrasive cloth.
2. Remove all oils and filings by brushing and cleansing with dishwashing compound. Allow to dry.

NOTE

Shield adjacent fabric material before spraying solid film lubricant. A small amount of lubricant will not damage fabric, but may cause discoloration and make fabric appear soiled.

3. Spray metal items with a solid film lubricant and allow to air dry for 24 hours.

END OF TASK

END OF WORK PACKAGE

**SERVICE MAINTENANCE
26-FOOT DIAMETER, HIGH-VELOCITY CARGO PARACHUTE ASSEMBLY
INSPECTION**

INITIAL SETUP**Equipment Condition**

Packed.

References

DA PAM 738-751

TB 43-0002-43

DA PAM 750-8

AR 750-1

WP 0008

WP 0010

AR 750-32

AFTO 391

DA Form 3912

NAVWPNCEN or NAVWPNS CL 13512/11

Personnel Required

92R1P Parachute Rigger

92R Supervisor

ROUTINE INSPECTION

A routine inspection is a visual check performed to ascertain the serviceability of all visible components of a parachute that is packed or rigged for use. The inspection will be made on all components that can be inspected without opening the parachute pack. Prior to issue, a parachute rigger will administer this inspection.

Check for Breakaway/Non-Breakaway prior to issue.

END OF TASK**PACK-IN-PROCESS INSPECTION**

A pack-in-process inspection is performed at specified intervals during the packing of a parachute to ensure that only authorized procedures and methods are being used. A parachute rigger supervisor, other than the packer or rigger preparing the applicable equipment for use, will accomplish the inspection. The intervals, at which the inspection is performed, are as follows:

WARNING

Deployment bag will be given a complete inspection, including static line and that portion of the static line that is covered by the static line sleeve. Failure to do so could result in serious injury or death to personnel.

NOTE

For Army personnel, the In-Process-Inspector (IP) qualifications are IAW AR 750-32.

1. After the parachute is placed in proper layout.
2. After the gores are folded and the flatfold is completed.
3. After the canopy is longfolded and the breakcord is tied.

4. After the deployment bag is closed (first regular stow).
5. After the suspension lines are stowed.
6. After the suspension line protector flap is closed.
7. After the static line is stowed and log record is complete.

END OF TASK

TECHNICAL/RIGGER-TYPE INSPECTION PROCEDURES

Perform inspection as follows:

1. Overall inspection. An overall inspection will be made on the 26-Foot HV parachute to ascertain the following:
 - a. Log record/parachute inspection data pocket and form. As applicable, inspect the assembly log record parachute inspection data pocket to ensure the Army Parachute Log Record (DA Form 3912), NAVWPNCEN or NAVWPNS CL 13512/11(Parachute History Record) is enclosed and properly attached. Further, remove the log record from the pocket and evaluate the recorded entries. Inspect and evaluate as follows:

The Army Parachute Log Record, DA Form 3912, and AFTO 391 are history-type maintenance documents that accompany the parachute canopy and pack tray assemblies through the period of service of the individual assembly. The log record provides a means of recording maintenance actions performed on a parachute canopy assembly. Normally, a log record is initiated and attached to a right rear riser upon receipt by a using unit. However, if the item is subjected to alteration or modification by a maintenance activity, during the interim period from date of manufacture to receipt by a using unit, the log record will be prepared by the activity performing the maintenance function. Once initiated, a log record will be attached to and contained in an affixed parachute log record/inspection data pocket, until such time as the parachute canopy assembly is destroyed or rendered unfit for further use or repair. Additionally, should an item that requires a log record be transferred from one unit to another, the log record for the parachute assembly will accompany the item in the transfer action. A prepared log record will not be removed or separated from a parachute, especially a packed parachute, except as directed by the local air delivery equipment maintenance activity officer. A log record that is illegible, lost, damaged, soiled, or precludes further entries due to lack of space, will be replaced upon the next repack or inspection, as applicable, with a serviceable item from stock.
 - b. Assembly completeness. Ensure the applicable assembly is complete and that no components (or parts) are missing.
 - c. Operation adequacy. Check the item components and parts to ensure proper assembly, which includes attachment and alignment, and that the assembled product functions in the prescribed manner. Further, ensure that no stitch formation (or sewn seam) has been omitted.
 - d. Markings and stenciling. Inspect each assembly and components for faded, illegible, obliterated, or missing informational data and identification numbers.
 - e. Foreign material and stains. Inspect each assembly and related components for the presence of dirt or similar type foreign material. Also check for evidence of mildew, moisture, oil, grease, pitch, resin, or contamination by salt water.
2. Detailed inspection. In addition to the overall inspection performed in 1, above, a detailed inspection will be performed on the materials that constitute the assembly or component construction, using the

following criteria, as applicable:

- a. Metal. Inspect for rust, corrosion, dents, bends, breaks, burrs, rough spots, sharp edges, wear, deterioration; damaged, loose or missing grommets, safety pins, connector snap, eye hook, pack fastener; improper swaging or welding; loss of spring tension; and missing or loose screws.
- b. Cloth. Inspect for breaks, burns, cuts, frays, holes, rips, snags, tears; loose, missing, or broken stitching or tacking; and weak spots, wear, or deterioration.
- c. Fabric tape, webbing, and cordage. Inspect for breaks, burns, cuts, frays, holes, snags, tears, incorrect weaving, and sharp edges formed from searing; loose, missing, or broken stitching, tacking, whipping, and weaving; weak spots, wear, and deterioration.
- d. Pressure-sensitive (adhesive) tape. Inspect for burns, holes, cuts, tears, weak spots, and looseness and deterioration.
- e. Rubber and elastic. Inspect for burns, cuts, holes, tears, weak spots, loss of elasticity and deterioration.

END OF TASK

IN-STORAGE INSPECTION

An in-storage inspection is a physical check conducted on a random sample of air delivery equipment that is located in storage. The purpose of the inspection is to ensure that the equipment is ready for issue, that the item is properly identified and segregated from other types of equipment, that no damage or deterioration of equipment has been incurred, and that all modifications or similar action requirements have been completed. The inspection shall also concern the methods and procedures applied to the storage of air delivery items, the adequacy of storage facilities, efforts of pest and rodent control, and protection against unfavorable climatic conditions. Air delivery equipment that is in storage will be inspected at least semiannually and at more frequent intervals if prescribed by the local parachute maintenance advisor. The frequency of inspection may vary according to the type of storage facilities and local climatic conditions. Only parachute rigger personnel designated by the local Airdrop Systems Technician (921A) or Senior Airdrop NCO (92R4P) and above, under guidance from an Airdrop Systems Technician assigned to the command at the Battalion level or higher, when no Airdrop Technician is assigned at the Company/Detachment/Team level, will conduct in-storage inspections.

END OF TASK

EQUIPMENT DISPOSITION

Air delivery equipment may be rendered unserviceable by either normal fair wear or by aging and will subsequently be repaired, modified, or condemned as appropriate. Equipment that is uneconomically repairable (outdated) will be condemned. Disposition of air delivery equipment that is condemned, unserviceable, or for which the serviceability is questionable, will be accomplished using the following procedures, as applicable:

1. Item requiring repair or modification. An air delivery item that requires repair or modification will be tagged in accordance with DA PAM 738-751. Subsequent work on the item will be performed at the maintenance level specified for the maintenance function in the applicable supporting technical publication and noted in the parachute log record.
2. Parachutes with exhausted age or service life. Any parachute component or air delivery equipment whose age or service life has expired as specified in TB 43-0002-43 will be removed from service,

condemned, and tagged as prescribed by DA PAM 738-751.

3. Disposition of condemned air delivery equipment. Condemned equipment, other than fatality parachutes, will be removed from service and disposed of in accordance with current directives listed in this Work Package.
4. Rejected equipment. Equipment which, prior to use, is deemed unserviceable for use will be reported in a PQDR in accordance with DA PAM 750-8, as authorized by AR 750-1. Each applicable item that is defective will be held and safeguarded pending receipt of disposition instructions from the National Maintenance Point (NMP). In all instances, PQDR exhibit material will be handled as prescribed in DA PAM 750-8. If the quality or the serviceability of an item is questionable, clarification and assistance may be obtained by contacting Commander, TACOM-LCMC, ATTN: AMSTA-LC-SECT, 15 Kansas Street, Natick, MA 01760-5052.
5. Equipment of doubtful serviceability. Equipment that has had previous use and has not exceeded normal fair wear or aging criteria, but of which further serviceability is doubtful, will be tagged as prescribed in DA PAM 738-751. In addition, the equipment will be reported in an EIR, in accordance with DA PAM 750-8 and AR 750-1. The item(s) in question will be held as EIR exhibit material as outlined in DA PAM 750-8, pending receipt of disposition instructions from the NMP. A maintenance activity holding EIR exhibit material will not tamper with the applicable item(s) or make any attempt to ascertain cause factors. Unnecessary handling of EIR exhibit material may disturb or alter peculiar aspects of the affected item(s) that might affect the judgment of engineering personnel who have the responsibility for final evaluation of EIR actions. If the quality or the serviceability of an item is questionable, clarification and assistance may be obtained by contacting Commander, TACOM-LCMC, ATTN: AMSTA-LC-SECT, 15 Kansas Street, Natick, MA 01760-5052.
6. Equipment immersed in salt water. Any air delivery item constructed from cotton material that has been immersed in salt water will be condemned. Cotton thread used for tacking and sewing on nylon parachute packs that have been immersed in salt water will only be replaced when there is visible evidence or deterioration, such as extreme discoloration or indications of broken thread. Any air delivery equipment constructed of nylon or rayon material that has been immersed in salt water for a period less than 24 hours, but which cannot be rinsed within 48 hours after recovery, will also be condemned. However, if the cited time limitations can be met, then immediately, upon recovery, suspend or elevate the recovered equipment in a shaded area and allow the item(s) to drain for at least 5 minutes. Do not attempt to wring the equipment fabric or the suspension lines. Within 48 hours after recovery, under the supervision of a qualified parachute rigger (92R1P), rinse the recovered equipment as indicated in WP 0008.

END OF TASK

END OF WORK PACKAGE

SERVICE MAINTENANCE
26-FOOT DIAMETER, HIGH-VELOCITY CARGO PARACHUTE ASSEMBLY
SALT-WATER/FRESH-WATER CONTAMINATION TEST

INITIAL SETUP:**Personnel Required**

92R1P Parachute Rigger

References

WP 0003

WP 0049

Equipment Condition

Laid out on packing table or other suitable area.

INSPECTION

Look for a white, crystalline residue. If evidence of salt-water/fresh-water contamination is found, refer to the procedures detailed below:

Rinsing Parachute Assembly Immersed in Salt Water

If the parachute, or any of its components, has been immersed in salt water in excess of 24 hours, it will be condemned. Additionally, if the parachute, or any of its components, has been immersed in salt water for a period less than 24 hours, but cannot be rinsed within 48 hours after recovery, it will also be condemned. However, if the cited time limitations can be met, then immediately, upon recovery, suspend or elevate the parachute assembly in a shaded area and allow it to drain for at least 5 minutes. Do not attempt to wring the fabric or the suspension lines. Within 48 hours after recovery, under the supervision of a qualified parachute rigger (92R1P), rinse the recovered parachute assembly as follows:

1. Place the parachute assembly in a large, watertight container filled with a suitable amount of fresh, clean water to cover the assembly.

NOTE

If the salt-water-soaked parachute assembly is too large to be placed into a rinsing container, then the rinsing process will be effected by applying fresh, clean water to the assembly using a hose.

2. Agitate the container contents by hand for 5 minutes.
3. Remove the parachute assembly from the container and suspend or elevate it in a shaded area, allowing a 5-minute drainage period. Do not attempt to wring the fabric or the suspension lines.
4. Repeat the procedures in steps 1 through 3 above, twice, using fresh, clean water for each rinse.
5. After the third rinse, allow the parachute assembly to drain thoroughly. Upon completion of draining, dry the assembly in accordance with the "Drying Fabric Items" procedures detailed below.
6. When dried, perform a technical/rigger-type inspection of the parachute assembly. Corroded metal components, or corrosion-stained fabrics or suspension lines, will be either repaired or replaced as prescribed by the Maintenance Allocation Chart (MAC) in WP 0049.

7. Record any repair, immersion, and rinsing in the parachute log record as shown on the "Notes" page in WP 0003.

END OF TASK**Rinsing Parachute Assembly Immersed in Fresh Water**

Any parachute, or its components, that has been immersed in a fresh-water lake, river, or stream will not require rinsing unless it has been ascertained that the water is dirty, oily, or otherwise contaminated. Procedures for handling a fresh-water immersed parachute are as follows:

1. Uncontaminated fresh water. If the parachute, or its components, has been immersed in contaminated fresh water, rinse and dry, and, if applicable, repair.
2. Contaminated fresh water. If the parachute, or its components, has been immersed in contaminated fresh water, it will be cleaned and dried as outlined in "Cleaning Fabric Items With a Solution of Hand Dishwashing Compound," "Drying Fabric Items", and "Cleaning Metal Items", in the detailed paragraphs above and below. Minor discoloration of fabric items, resulting from immersion in contaminated fresh water, may occur.

END OF TASK**NOTE**

Fabric items will not be dried in direct sunlight or by laying an item on the ground.

Drying Fabric Items

Dry fabric items as follows:

1. Suspend or elevate the item in a well-ventilated room or in a heated drying room.
2. Using electric circulating fans may reduce drying time.
3. When heat is used, the heat temperature shall not exceed 160 degrees Fahrenheit (71 degrees Celsius). The preferred temperature is 140 degrees Fahrenheit (60 degrees Celsius).

END OF TASK**END OF WORK PACKAGE**

**SERVICE MAINTENANCE
26-FOOT DIAMETER, HIGH-VELOCITY CARGO PARACHUTE ASSEMBLY
PACKING PROCEDURES**

INITIAL SETUP:**Tools**

Packing Weight (WP 0049, Item 11)
Line Separator (WP 0049, Item 7)
Packing Paddle (WP 0049, Item 10)
Knife (WP 0049, Item 5)
Tension Plate (WP 0049, Item 21)

Personnel Required

92R1P Parachute Rigger
92R Supervisor

Equipment Condition

Parachute cleaned (WP 0008) and given a shakeout (WP 0007).

Materials/Parts

Retainer Band, Rubber (WP 0050, Item 1)
Cord, Nylon, Type III (WP 0050, Item 14)
Thread, Cotton, Ticket No. 8/7 (WP 0050, Item 31)
Webbing, Nylon, Tubular, $\frac{3}{4}$ -in. NAT (WP 0050, Item 45)
Webbing, Cotton, Type I, $\frac{1}{4}$ -in. (WP 0050, Item 41)
Tape, Pressure Sensitive (WP 0050, Item 30)

References

T.O. 13C-1-41
NAVAIR 13-1-17
DA PAM 738-751
TB 43-0002-43
DA Form 3912
WP 0009

WARNING

Failure to detect areas of damage may result in malfunction of the parachute and injury or loss of life to personnel.

NOTE

The parachute shall be repacked every 365 days.

INSPECTION

If defects or damages are discovered during inspection of a parachute, the parachute must be rigger-rolled and processed for maintenance in accordance with DA PAM 738-751. A technical/rigger-type inspection and a pack-in-process inspection must be performed in conjunction with the packing of each parachute.

1. Technical/rigger-type inspection. Before each parachute is packed by air delivery, it must be given a technical/rigger-type inspection by the packer in accordance with WP 0009.
2. Pack-in-process inspection. A designated supervisory rigger, other than the packer, must perform a pack-in-process inspection at seven (7) intervals during the packing procedure. The inspection is performed to ensure that the parachute is packed according to authorized packing procedures (refer to WP 0009).

END OF TASK**ORIENTATION**

Throughout this manual, all directions (right, left, upper, lower, top, bottom, clockwise, and counterclockwise) are given from the rigger's point of view, as the rigger stands at the tension plate end of the packing table, facing the apex-hook end of the table.

1. Top. That portion of the equipment that is farthest from the packing table surface.
2. Bottom. That portion of the equipment that is nearest to the packing table surface.

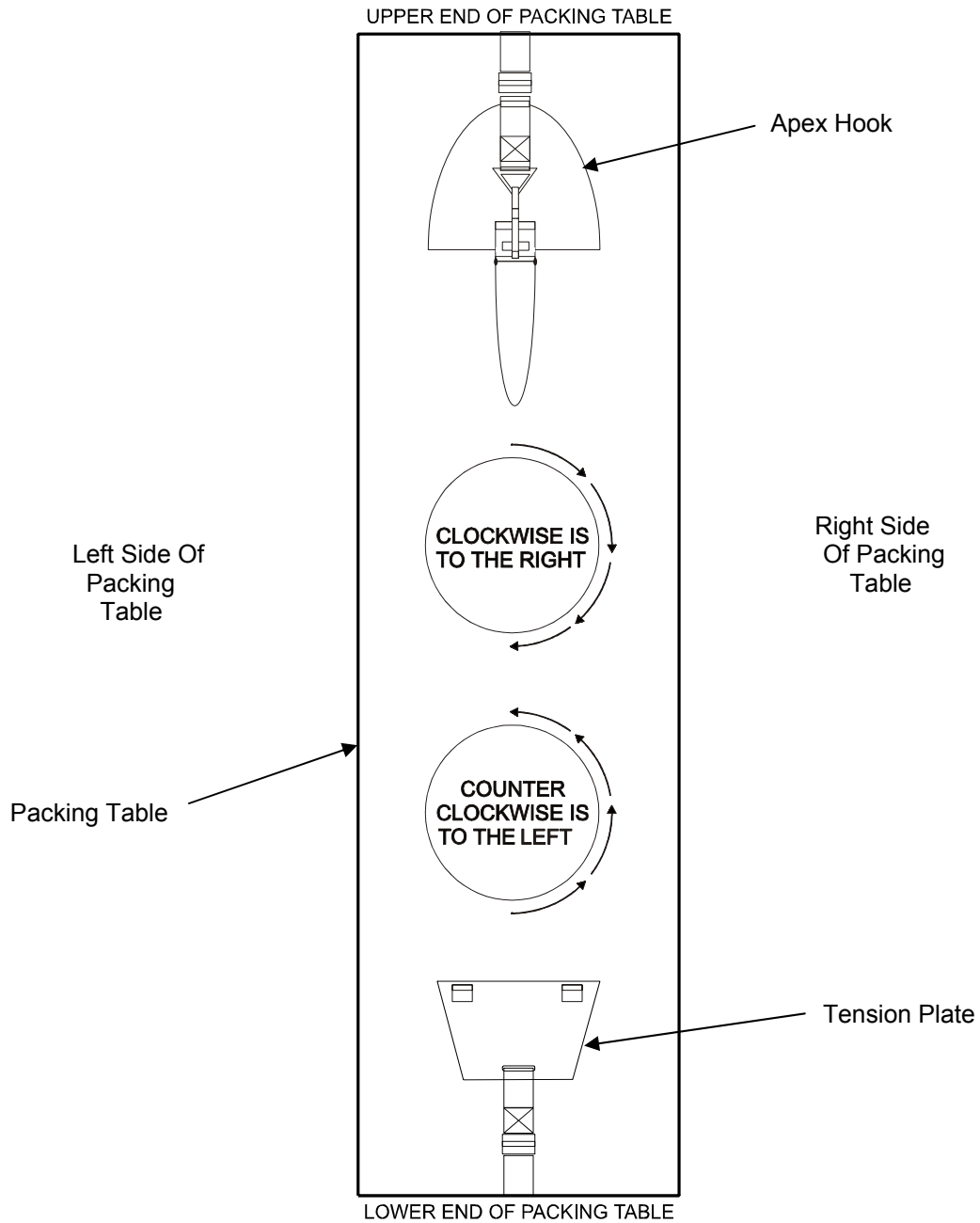

Figure 1. Rigger's View.

END OF TASK

PREPARING THE PARACHUTE FOR PROPER LAYOUT

Prepare the parachute as follows:

1. Place packing tools in convenient locations on the packing table.
2. Lay the canopy assembly lengthwise on the packing table and attach the bridle loop to the packing table apex hook.

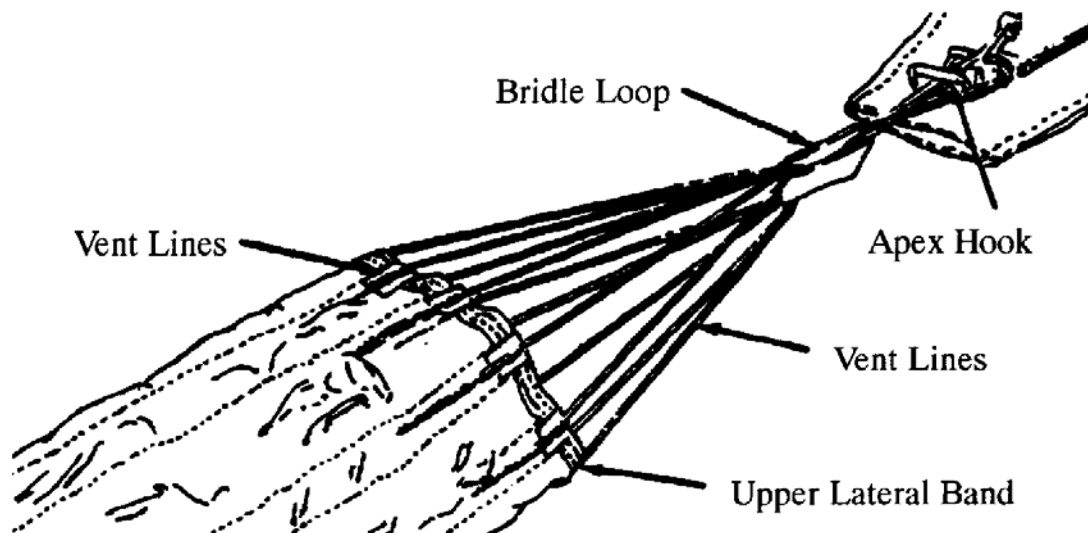

Figure 2. Canopy Attached to Packing Table Apex Hook.

NOTE

When inversion, turns, tangles, and twists are present in the canopy assembly, the proper sequence for removal, to achieve proper layout, is to remove an inversion first, remove turns secondly, then remove tangles, and, finally, remove twists.

END OF TASK

REMOVING INVERSION

To remove an inversion, proceed as follows:

1. Canopy inversion. Check canopy vent lines to determine if canopy has been inverted. Canopy is inverted when vent lines are located inside upper lateral band (Figure 2). Remove inversion as follows:

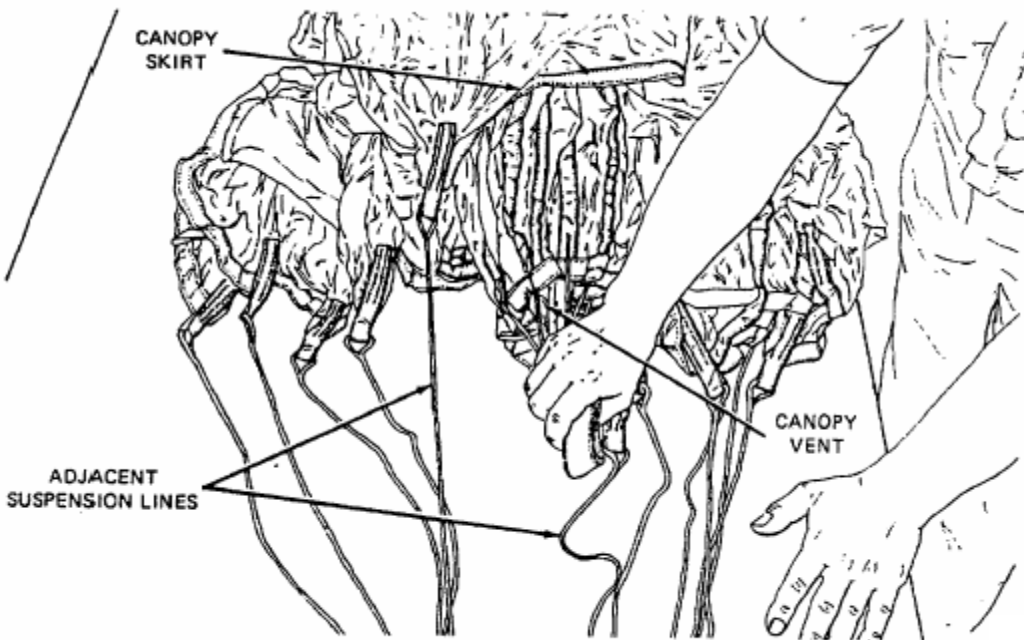

Figure 3. Removing Inversion.

- a. Detach bridle loop from apex hook and pass bridle loop through canopy.
 - b. Pass bridle loop out of canopy skirt, between two adjacent suspension lines (Figure 3).
2. Partial inversion. If vent lines are on outside of canopy and pocket bands are on inside, or vice versa, a partial inversion exists. Remove a partial inversion as follows:
 - a. Detach bridle loop from apex fitting. Trace radial and vertical tapes to annular ring where tapes turn under to inside canopy (Figure 4).
 - b. Pull canopy vent or risers through canopy and out through annular ring. Attach bridle loop to apex hook on packing table.

END OF TASK

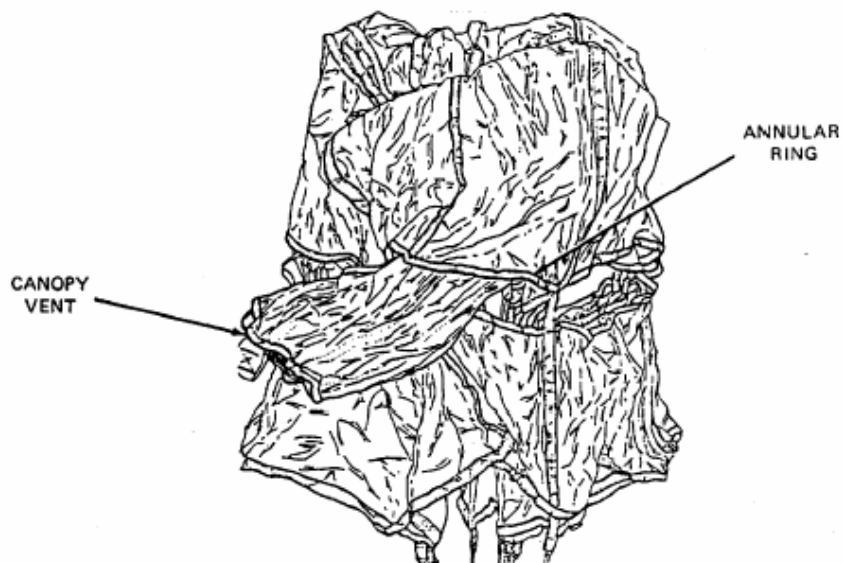

Figure 4. Removing Partial Inversion.

REMOVING TURNS

Remove turns as follows:

A turn exists when one group of suspension lines is rotated around opposite group or lines. To remove a turn, rotate lines in a direction opposite to direction of turn (Figure 5).

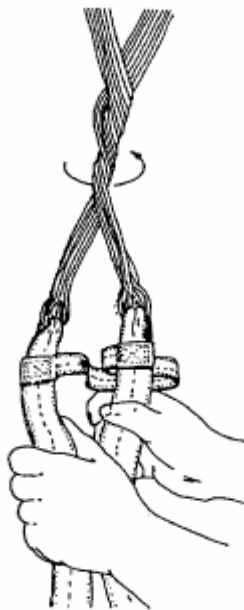

Figure 5. Removing Turns.

END OF TASK

REMOVING TANGLES

Remove tangles as follows:

1. Maintain separation between two line groups and work tangle(s) to a point close to risers.
2. With the left hand, select top line(s) forming the tangle and lift them away from remaining lines.
3. Reach through formed opening with right hand and pull risers through opening (Figure 6).



Figure 6. Removing Tangles.

END OF TASK

REMOVING TWISTS

Remove twists as follows:

1. Grasp top inside suspension lines of canopy skirt and trace these lines down to risers (Figure 7).
2. Rotate risers between suspension line groups in a direction opposite to that of a twist.
3. Attach risers to tension plate.

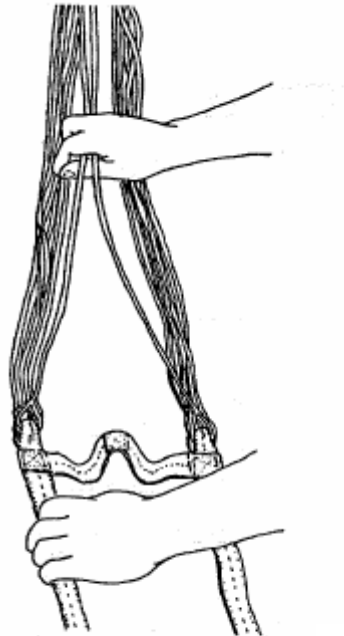

Figure 7. Removing Twists.

END OF TASK

PROPER LAYOUT

1. Locate top, center gore of canopy and divide suspension lines into two groups. Lines 1 through 13 should be in left group, lines 14 through 26 in right group, lines 1 and 26 should be located on top of their respective groups, and lines 13 and 14 on the bottom (Figure 8).
2. Check canopy assembly for proper layout by raising top and bottom center gores and tracing suspension lines to connector loops. Check lines 1, 26, 13, and 14 for proper position (Figure 9).

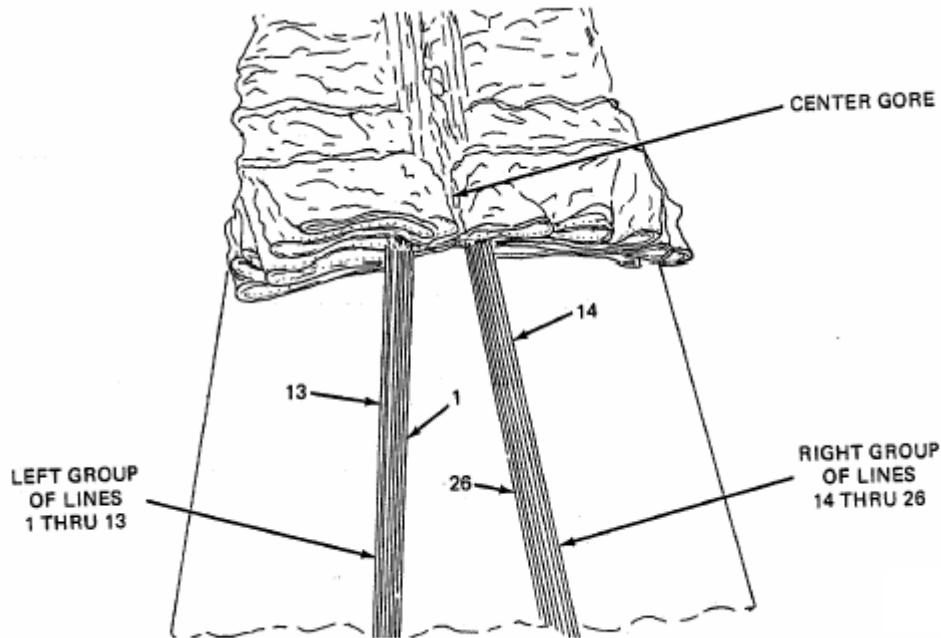

Figure 8. Suspension Line Separation.

END OF TASK

ASSEMBLY

NOTE

When the parachute is received from the supply activity, before it is packed for use, the components must be assembled. This must be accomplished during the layout of parachute (described in this work package), after removing inversions, turns, tangles, or twists, as required.

In assembling components, if any component is found to be defective, item must be processed for repair. Place components on the packing table and obtain proper layout of canopy assembly; then assemble components in accordance with the following:

1. Attaching static line.
 - a. If applicable, remove riser clevis or snap hook from small loop on 15-foot long static line.
 - b. Pass large loop located on one end of static line through deployment bag main strap attaching loop (Figure 9).
 - c. Pass opposite end of static line through large loop and draw formed loop tight against main strap attaching loop.

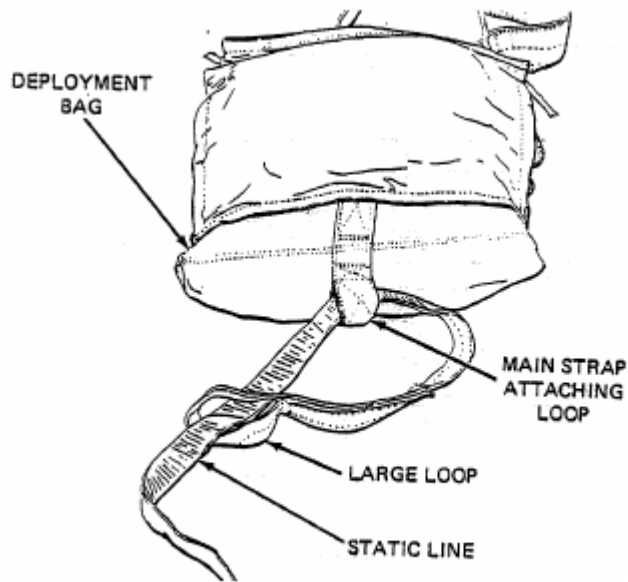

Figure 9. Attaching Static Line to Deployment Bag.

2. Prepare deployment bag with rubber retaining bands.
 - a. Attach 8 rubber retaining bands at equally spaced intervals on each suspension line-retaining strap located on top of the bag.
 - b. Attach rubber retaining bands to the static line retaining straps, 4 on the upper left and 3 on the upper right side of the bag.
3. 15-FT USL (Universal Static Line) may be used by attaching in the same manner as 1 and 2 above (Figure 9).

END OF TASK

RIGGER CHECK # 1: GORE FOLDING AND FLAT FOLD

1. Dress the apex and apply tension to canopy assembly.
2. Pick up right group of suspension lines with left hand. Holding top gore in position, flip right group of gores over left group of gores (Figure 10).
3. Beginning with line 14, fold right group of gores.

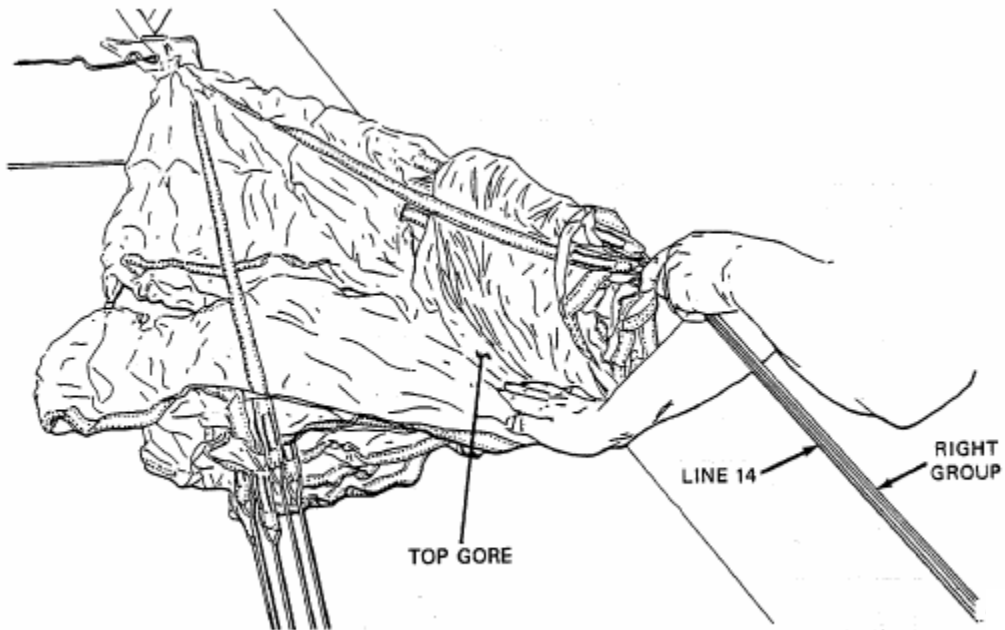

Figure 10. Flipping Right Gore Group.

4. Using right hand, scissor-grip right gore group of suspension lines between middle and index fingers. Rotate right group one-quarter turn clockwise (Figure 11).

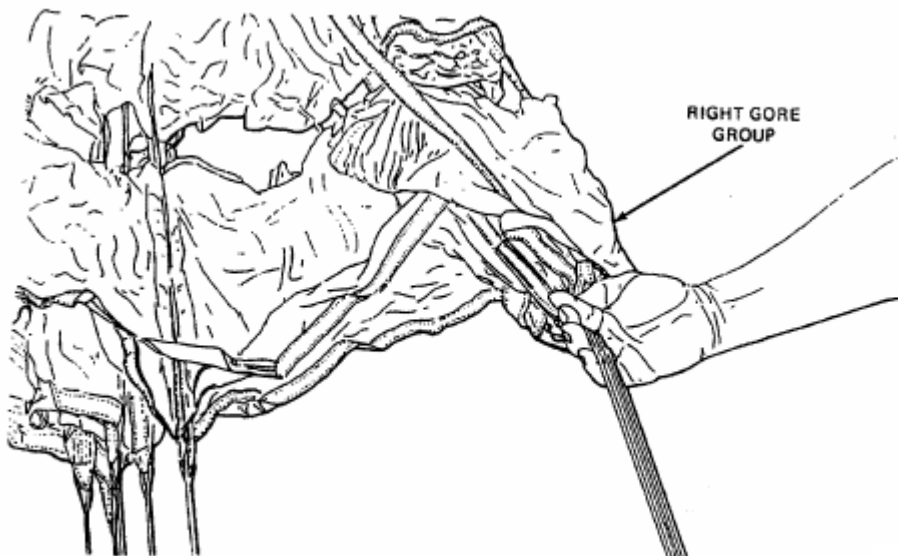

Figure 11. Right Gore Group Fold Complete.

5. Beginning with line 1, fold left group of gores, not including last two gores in group.

6. Raise last suspension line in left gore group; drape last gore on left. Drape next-to-last gore on right. Place last suspension line on top of other lines in left group.
7. Insert the two suspension line groups into line separator, just below canopy skirt.
8. Using left hand, hold line separator and separate suspension lines. Grasp canopy with right hand, pull canopy off right side of table, allowing folded gores to drape to side of table (Figure 12).

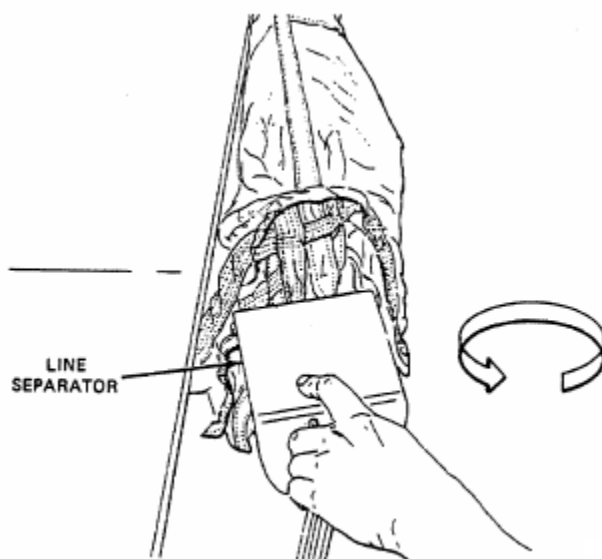

Figure 12. Draping Folded Gores to Right Side of Table.

9. Slide canopy back onto table and rotate suspension lines and line separator one-half turn counter-clockwise, allowing separator base to rest on table.
10. Place packing weight below line separator and apply additional tension (Figure 13).

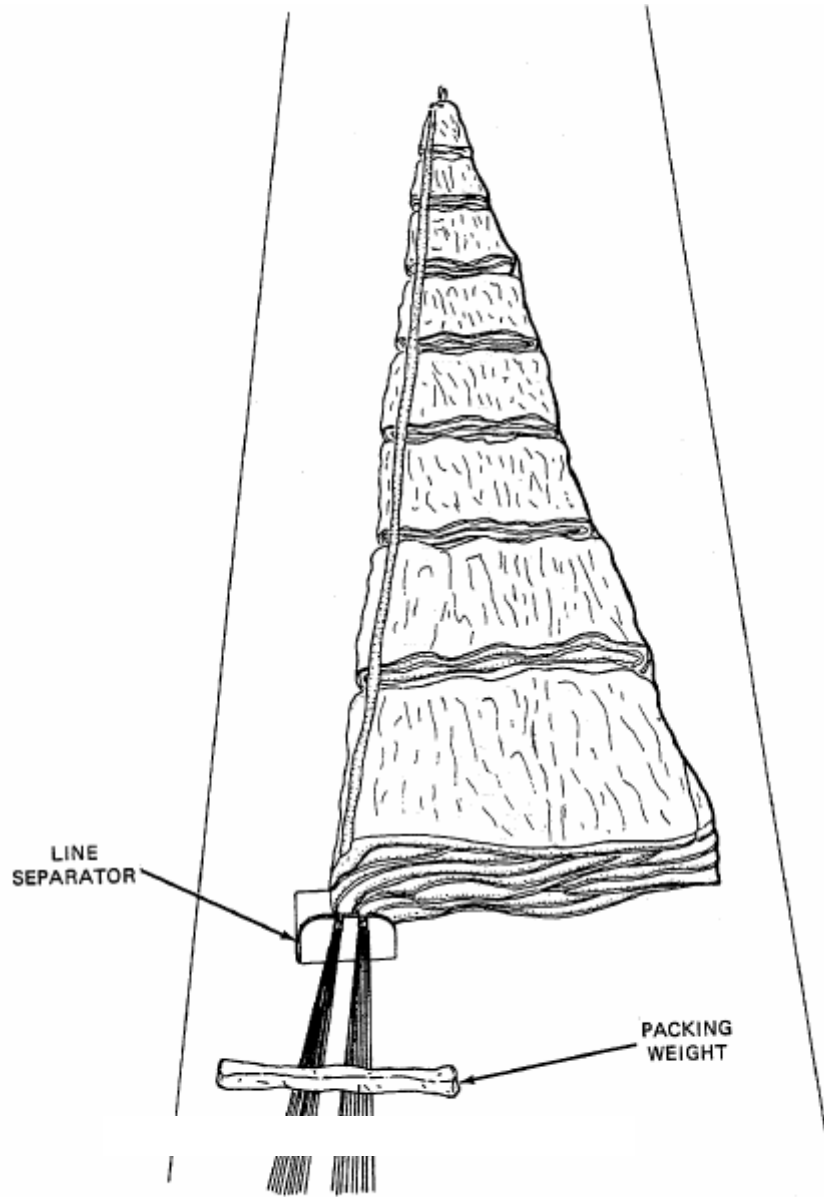

Figure 13. Folding Completed, Lines Separated.

11. To complete canopy flat fold, flip left group of gores to left side and dress gores and lower lateral band. Ensure correct number of gores are in each gore group and that a clear channel exists between the two gore groups (Figure 14).

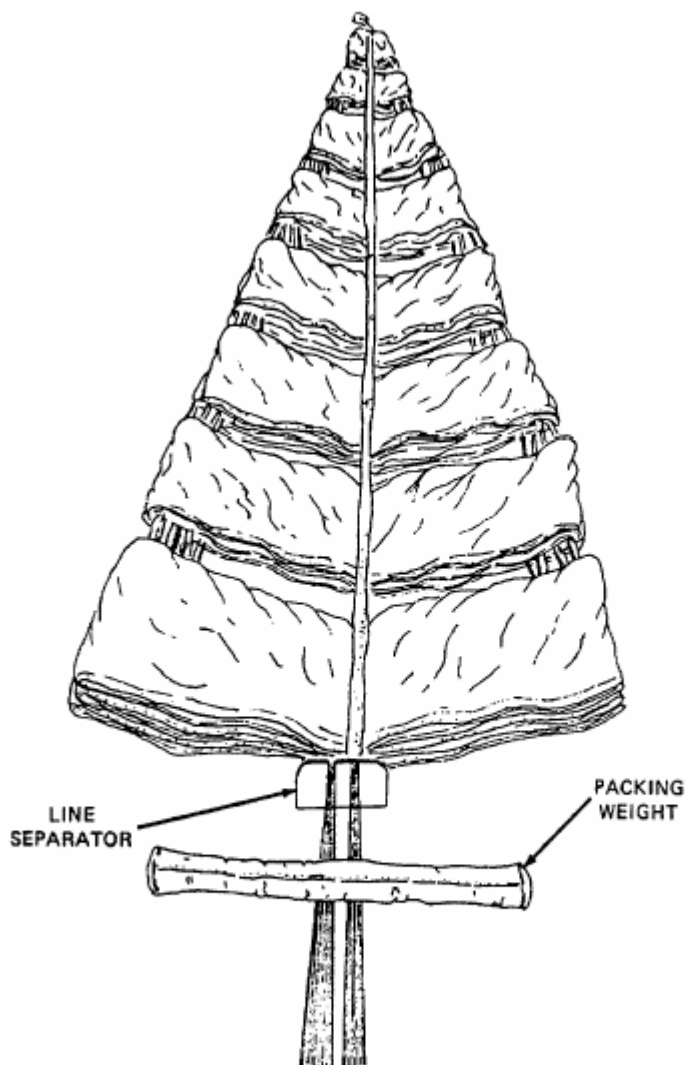

Figure 14. Canopy in Flat Fold.

END OF TASK

RIGGER CHECK # 2: LONG FOLDING THE CANOPY AND TYING BREAKCORD

After flat folding, the canopy is ready for long folding as follows:

1. Grasp the edges of the right group of gores with the left hand, with the right hand approximately 2 feet from the left hand. Fold edges over the radial tape (approximately 2 inches). Secure the fold with a packing weight.
2. Continue folding right group of gores, working toward the apex. Taper the fold until it breaks at a point approximately 36 inches from the apex. Secure fold with packing weights.

3. Fold the left group of gores in a similar manner, adjusting packing weights to hold both groups of gores (Figure 15). Long fold is completed.

NOTE

After long folding, the canopy should be the width of the deployment bag at the lower lateral band.

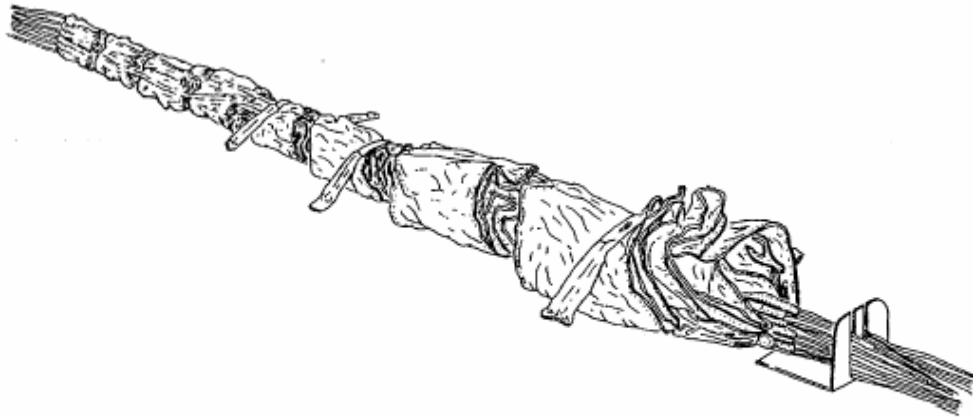

Figure 15. Canopy Longfolded.

4. Attaching cotton deployment bag with non-breakaway static line. (Cotton Bag)
 - a. Cut a 36-inch length of $\frac{1}{4}$ -inch-wide Type I cotton webbing and double the webbing length. This length shall be used as a breakcord.
 - b. Position deployment bag attaching loop (located on inside of bag) adjacent to canopy bridle loop (Figure 16).
 - c. Pass one end of the doubled webbing length through bridle loop and draw the webbing through until center of breakcord length is reached. Pull both ends of centered breakcord taut.
 - d. Working from opposite directions, pass each end of breakcord through deployment bag attaching loop and pull the webbing ends until a 3-inch loop is formed between the bridle loop and the bag attaching loop (Figure 16, A).
 - e. Secure two ends over deployment bag attaching loop (Figure 16, B) with a surgeon's knot and locking knot. Trim ends to two inches.
 - f. Reattach riser clevis to small loop on static line running end (Figure 16, C) and secure clevis with attached clevis pin and safety pin (Figure 16, C).

WARNING

Proper breakaway/non-breakaway packing is required. Failure to properly pack/rig may result in malfunction in the extraction or deployment phase. Failure to observe these precautions could result in injury to personnel and/or damage to equipment may occur.

5. Attaching deployment bag retaining tie and breakaway static line.
 - a. Cut a 40-inch length of ½-inch-wide tubular nylon webbing for use as retaining tie.
 - b. Position deployment bag attaching loop adjacent to canopy bridle loop.
 - c. Pass retaining tie through canopy bridle loop and pull tie through until center of webbing is reached. Pull two ends of retaining tie taut.
 - d. Working from opposite directions, pass each end of retaining tie through deployment bag attaching loop. Pull ends until 8-inch loop is formed in attaching tie between bridle loop and deployment bag attaching loop (Figure 17, A).
 - e. Secure two ends over deployment bag attaching loop with a surgeon's knot and a locking knot, as shown in B, Figure 17. Make an overhand knot in each running end. Trim ends 2 inches from knot.
 - f. Using a 2 ½-inch length of pressure sensitive tape, make 1½ turns through and around static line small loop (Figure 17, C).
 - g. Cut an 18-inch length of Type III nylon cord and remove core threads.
 - h. Pass one end of cord length through riser clevis body and pull through until center of cord is reached.
 - i. Working from opposite directions, pass each end of cord through static line small loop. Pull cord ends to form a 4-inch loop.
 - j. Secure cord ends around static line small loop with a surgeon's knot and locking knot. Make an overhand knot in each cord running end. Trim ends to 2 inches from knots (Figure 17, C).

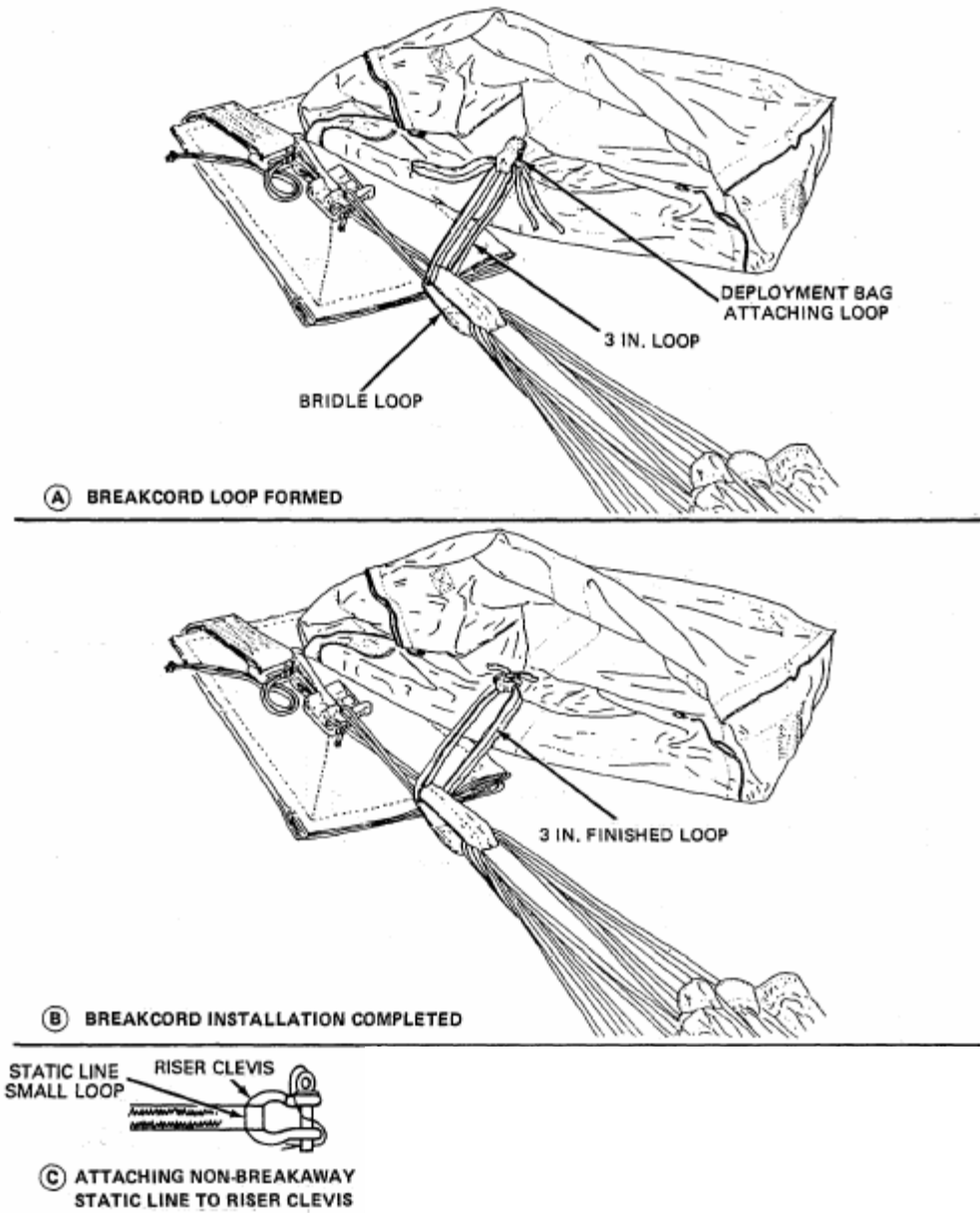

Figure 16. Attaching Cotton Deployment Bag for Non-Breakaway Static Lines.

END OF TASK

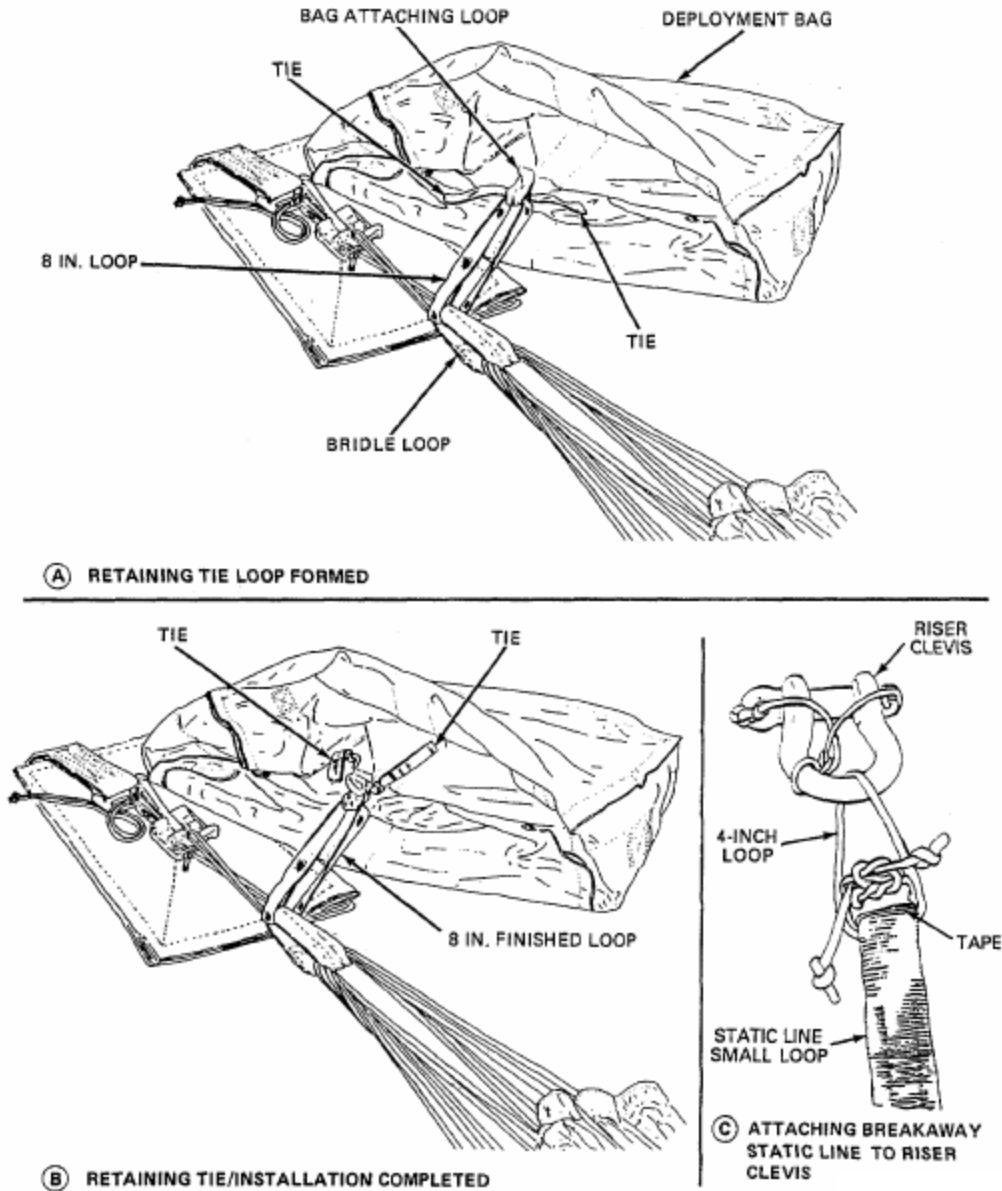

Figure 17. Attaching Cotton Deployment Bag Retaining Tie and Breakaway Static Lines.

For the Nylon Deployment Bag

6. Attaching deployment bag with the non-breakaway static line:

- a. Cut a 36-inch length of 1/4-inch wide, Type I cotton webbing and double the webbing length. This length shall be used as a breakcord.
- b. Position deployment bag retaining line (located outside of bag, attached to deployment bag attachment loop) adjacent to the canopy bridle loop, as shown in Figure 18.

- c. Pass one end of the doubled webbing length through bridle loop and draw the webbing through until center of breakcord length is reached. Pull both ends of centered breakcord taut.
- d. Working from opposite directions, pass each end of breakcord through deployment bag retaining line and pull the webbing ends until a 3-inch loop is formed between the bridle loop and the bag retaining line, as shown in Figure 18.
- e. Secure two ends over deployment bag retaining line with a surgeon's knot and locking knot, as shown in Figure 18. Trim ends approximately to 2 inches.
- f. Reattach riser clevis to small loop on static line running end and secure clevis with attached clevis pin and safety pin.
- g. Universal Static Line (USL) may also be used.

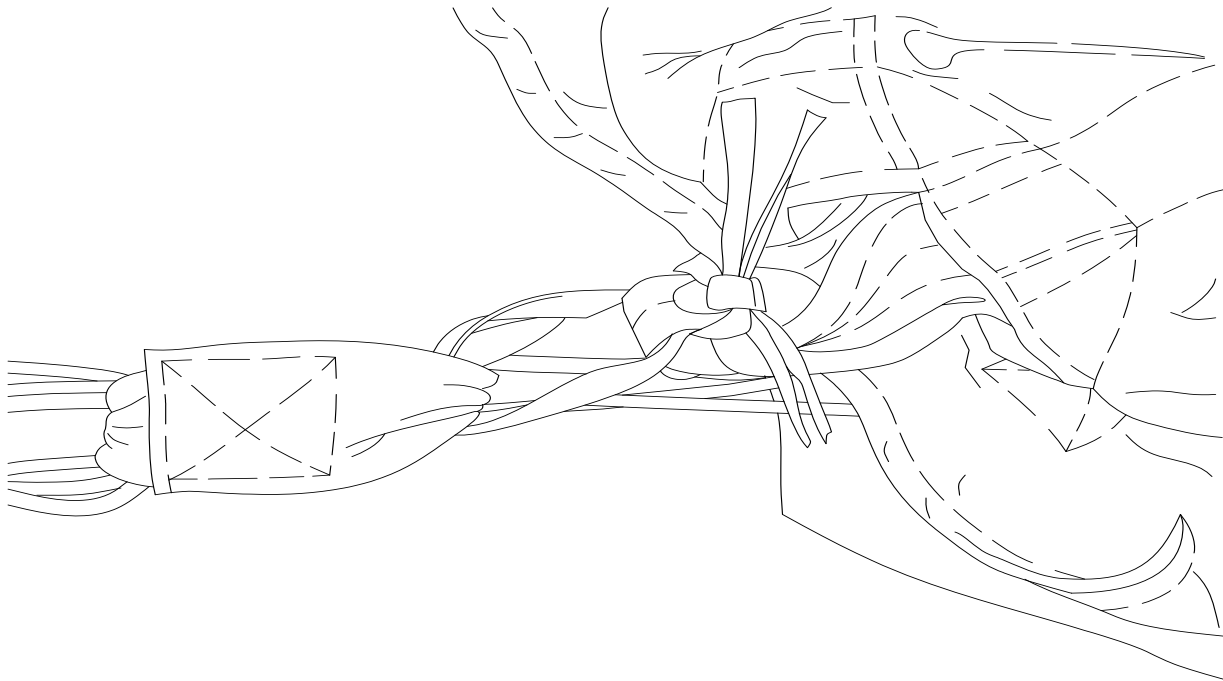

Figure 18. Attaching Nylon Bag for Non-Breakaway Static Line.

END OF TASK

RIGGER CHECK # 3:

7. Attaching nylon deployment bag with the breakaway static line:
 - a. Cut a 40-inch length of ½-inch wide tubular nylon webbing for use as a retaining tie.
 - b. Position deployment bag retaining line adjacent to the canopy bridle loop.
 - c. Pass retaining tie through canopy bridle loop and pull tie through until center of webbing is reached. Pull two ends of retaining ties taut.
 - d. Working from opposite directions, pass each end of retaining tie through deployment bag retaining line. Pull ends until 8-inch loop is formed in attaching tie between bridle loop and deployment bag retaining line, as shown in Figure 19.

- e. Secure two ends over deployment bag retaining line with a surgeon's knot and locking knot, as shown in Figure 19. Make an overhand knot in each running end. Trim ends 2 inches from knot.

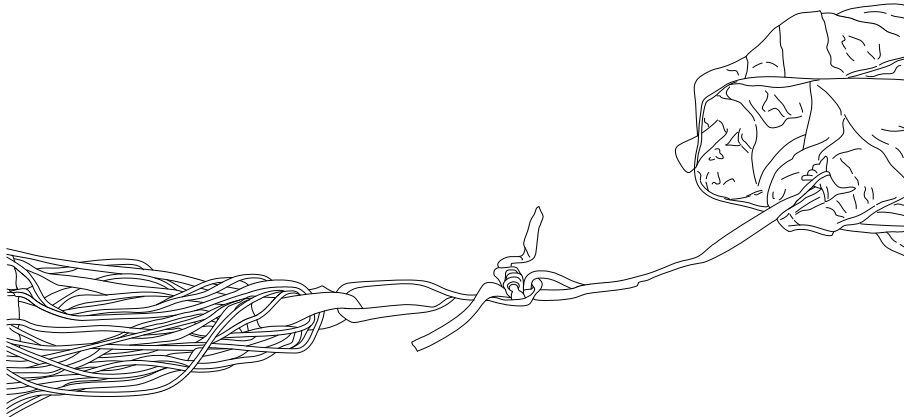

Figure 19. Retaining Tie.

- f. Using a 2½-inch length of pressure sensitive tape, make 1½ turns through and around static line small loop.
- g. Cut an 18-inch length of Type III nylon cord and remove core threads.
- h. Pass one end of cord length through riser clevis body and pull through until center of cord is reached.
- i. Working from opposite directions, pass each end of cord through static line small loop. Pull cord ends to form a 4-inch loop (Figure 17, C).
- j. Secure cord ends around static line small loop with a surgeon's knot and locking knot. Make an overhand knot in each cord running end. Trim ends 2 inches from knots.
- k. If using Universal Static Line (USL), remove girth hitch from snap hook. Cut an 18-inch length of Type III nylon cord and remove cord threads.
- l. Pass one end of the cord through the lower opening in the base of the snap hook and pull through until you reach the center of the cord (Figure 20).
- m. Working from opposite directions, pass each end of the cord through the lower opening of one of the snap hooks. Pull cord ends to form a 4-inch loop.



END OF TASK

Figure 20. USL Snap Hook Cord Connection.

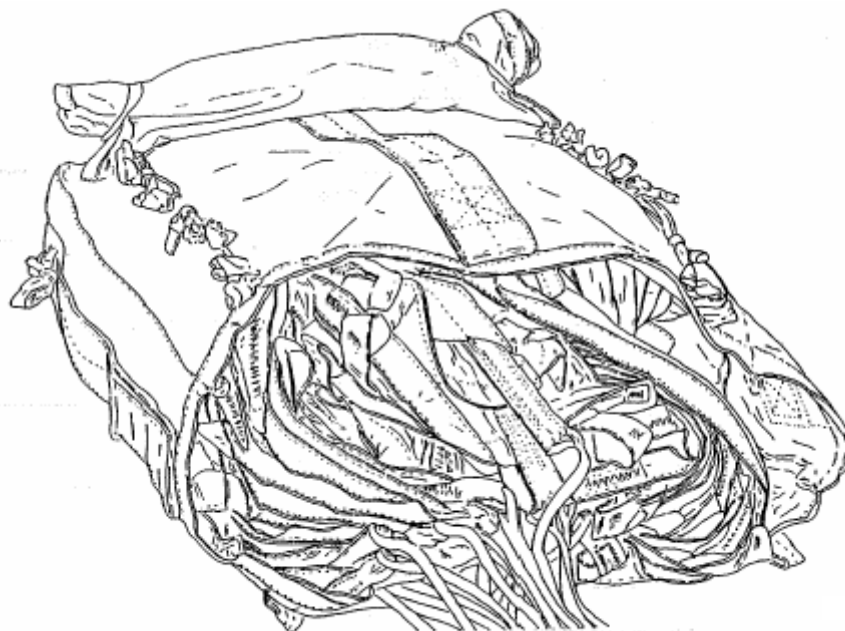

Figure 21. Canopy Stowage Completed.

STOWING THE CANOPY

1. Release the apex hook device.
2. Grasp canopy just below upper lateral band with left hand. Insert canopy vent into upper right-hand corner of deployment bag.
3. S-fold the canopy into the deployment bag.
4. Complete canopy stowage, with suspension lines extending from center of bag open end (Figure 21).
5. Using a 24-inch length of $\frac{1}{4}$ -inch-wide Type I cotton webbing, make a one-turn, single bag closing tie by tying top and bottom center bag tie loops around extended suspension line (Figure 22).
6. Secure tie with a surgeon's knot and a locking knot. Trim ends to 2-inches (Figure 22).
7. Flatten deployment bag.

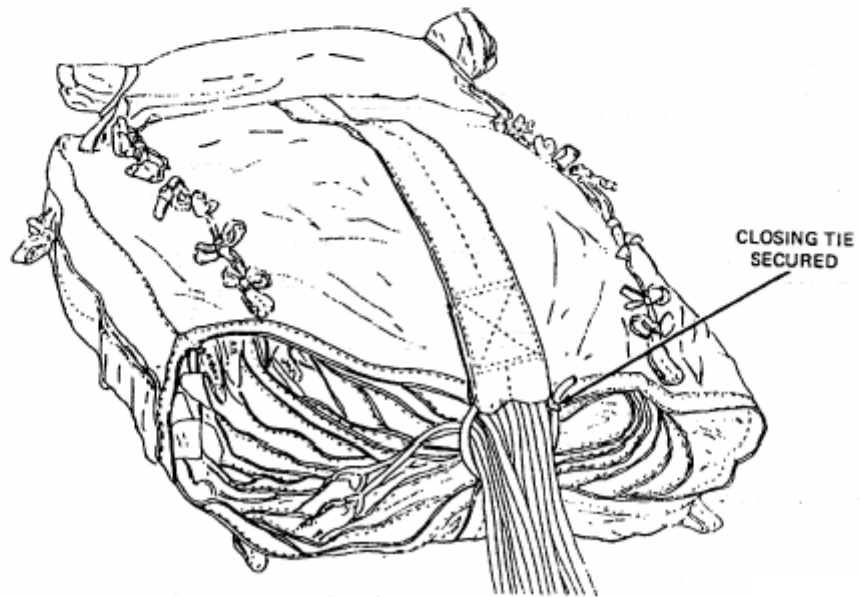
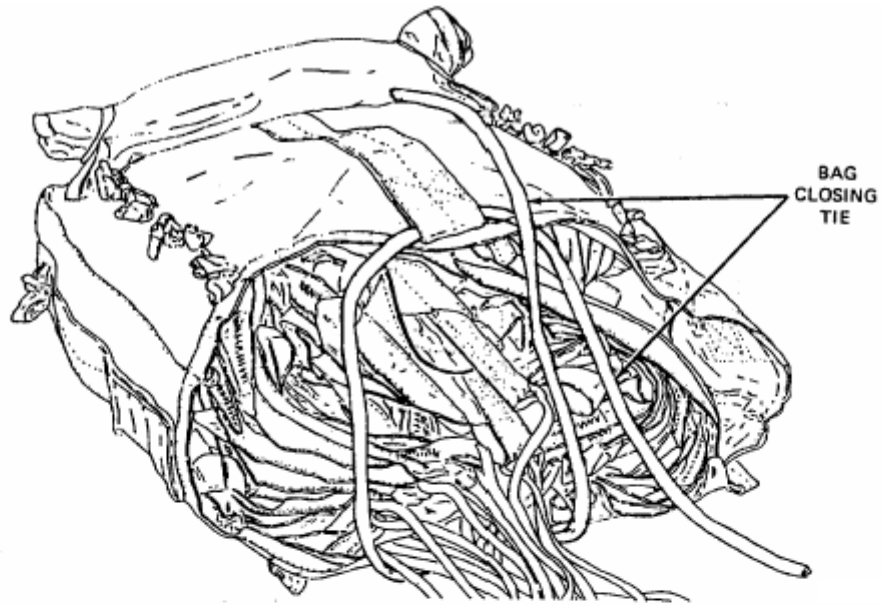

Figure 22. Bag Closing Tie Completed.

END OF TASK

RIGGER CHECK # 4: STOWING SUSPENSION LINES

1. Form and make the first suspension line stow at the upper right corner of deployment bag. Secure all stows with a single wrap of a rubber retaining band (Figure 23).

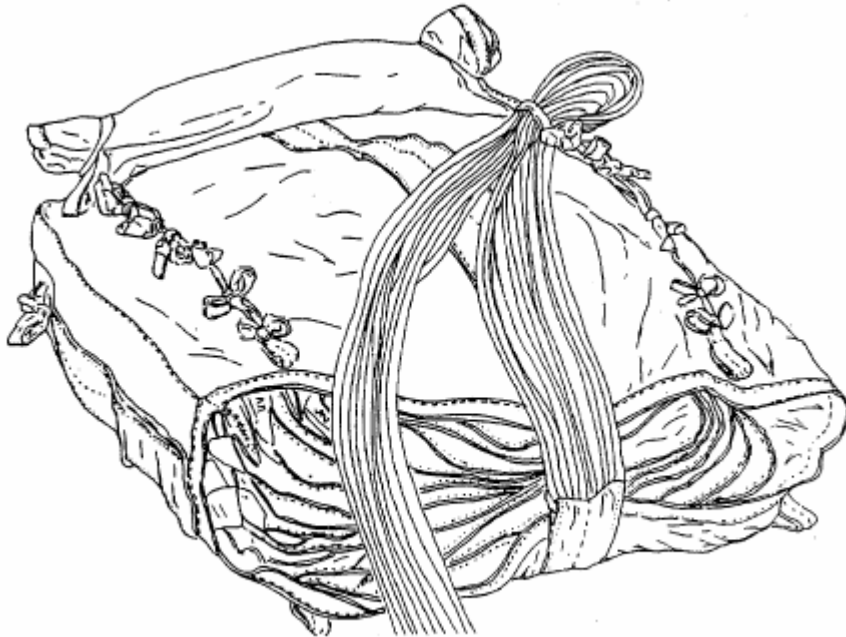

Figure 23. First Suspension Line Stow.

2. Extend suspension lines to left side of bag. Form and make second suspension line stow at upper left corner of bag, simultaneously rotating bag one-quarter turn, counterclockwise. Secure stow with a rubber retaining band (Figure 24).

NOTE

The width of stows will not exceed the width of the suspension line protector flap.

3. Working from right to left and moving bag toward tension plate, stow remaining suspension lines, securing each stow with a rubber retaining band, making last stow at a point 5 inches from riser connector loops and rotate bag one-quarter turn clockwise (Figure 25).

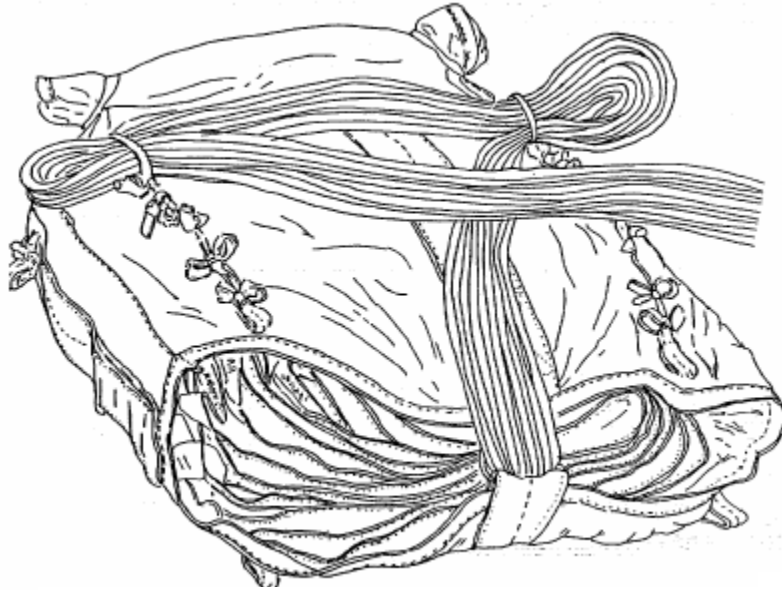

Figure 24. First and Second Suspension Line Stows Completed.



Figure 25. Suspension Line Stow Completed.

END OF TASK

RIGGER CHECK # 5: RISER SECURING TIES

1. Position riser connector loop at a point immediately below open end of bag.
2. Cut two 18-inch lengths of thread cotton, ticket number 8/7 for use as tie material.
3. Working in a counterclockwise direction, thread one 18-inch length through the left bottom bag tie loop, through the left riser connector loops, and through the left top bag tie loop (Figure 25).
4. Working in a clockwise direction, thread second 18-inch length through right bottom bag tie loop, through right riser connector loops, and through right top bag loop.



Figure 26. Riser Securing Ties Positioned.

5. Secure each tie, installed in 3 and 4 above, with a surgeon's knot and a locking knot (Figure 26). Ensure the knots are located to the outside of the bag tie loops.
6. Close suspension line protector flap over stowed suspension lines.
7. Pass one running end of left riser, securing tie through protector flap left tie loop, and secure running ends with a surgeon's knot and a locking knot. Trim ends to 2 inches (Figure 28).
8. Secure protector flap right tie loop using procedures in 7 above.

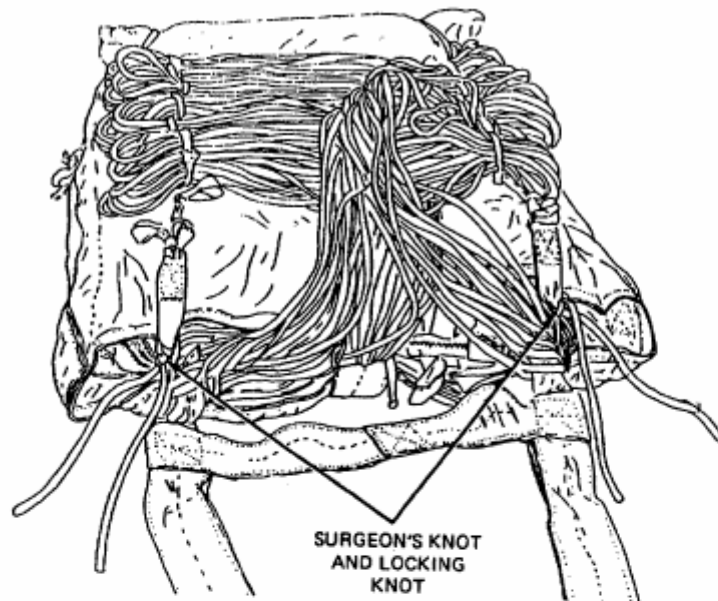

Figure 27. Riser Securing Ties Completed.

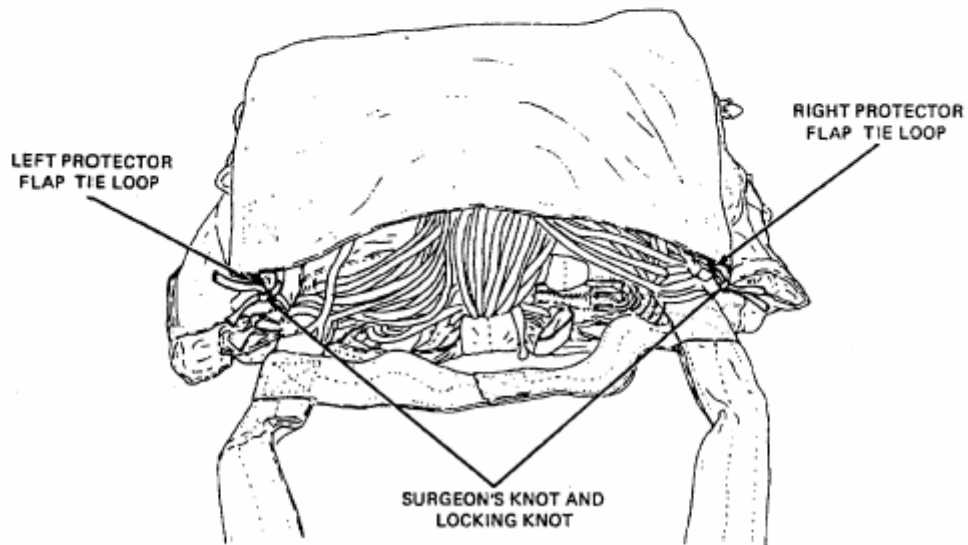

Figure 28. Suspension Line Protector Flap Closed and Secured.

END OF TASK

RIGGER CHECK # 6: COMPLETING THE PACK

1. Stow the static line by forming the first stow at the upper left corner of the deployment bag and secure the stow with a double wrap of the rubber retainer band attached to the static line retaining strap.

NOTE

Make the first stow and each succeeding stow to extend 2 inches beyond the outer edges of the static line retaining straps. Secure all stows with a double wrap of the rubber retainer bands.

2. Form the second static line stow at the upper, right corner of the bag and secure the stow with a rubber retainer band as in 1 above.
3. Continue stowing the remaining static line length, from left to right alternately, until the line is completely stowed and secured (Figure 29).
4. Remove log record (DA Form 3912) from the parachute inspection data pocket (log record pocket) located on the riser.
5. Make entries on the "Jump, Inspection and Repack Data" page as follows:
 - a. Date. Enter the day, month, and year of each packing action.
 - b. Bag number. Indicate whether breakaway or non-breakaway static line attachment.
 - c. Routine inspection. No entry required.
 - d. Jumps or dropped. No entry required.
 - e. Repack. For initial packing, enter "IN"; thereafter, enter a checkmark in the column each time the parachute is repacked.
 - f. Packer's name. The packer performing the packing will sign this entry.
 - g. Inspector's name. The inspector who has performed the pack-in process inspection will sign this entry.
 - h. Unit. Enter the unit designation to which the packer and/or inspector are assigned.
6. Return the log record to the log record pocket upon completion of the entire Rigger Check.
7. Extend risers and clevis across the stowed static line toward the upper edge of bag and fold the clevis back against the extended risers (Figure 30).
8. Using two 10-inch lengths of ¼-inch wide, Type I cotton webbing, make a first temporary tie using a bow knot to secure the clevis body to the deployment bag main strap attaching loop. At a point near the clevis screw, make a second temporary tie using a bow knot to secure the clevis body to the two risers (Figure 30).

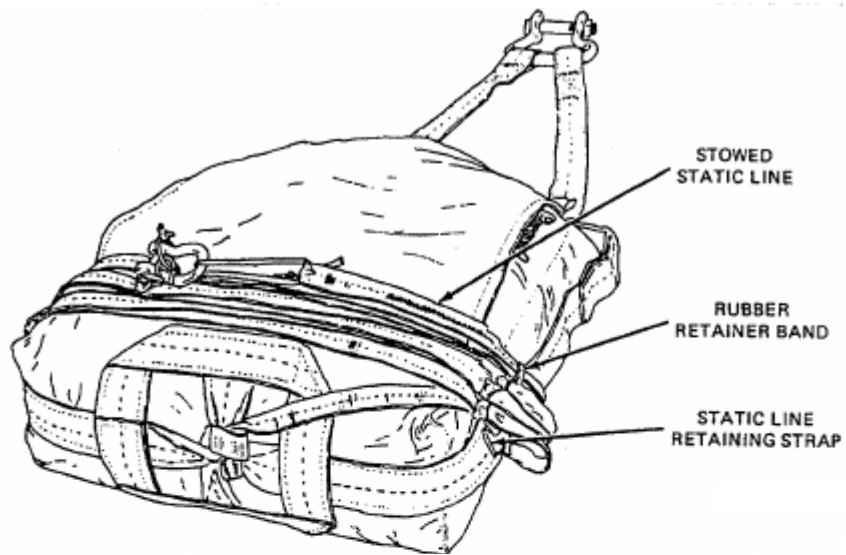

Figure 29. Static Line Stowed and Secured.

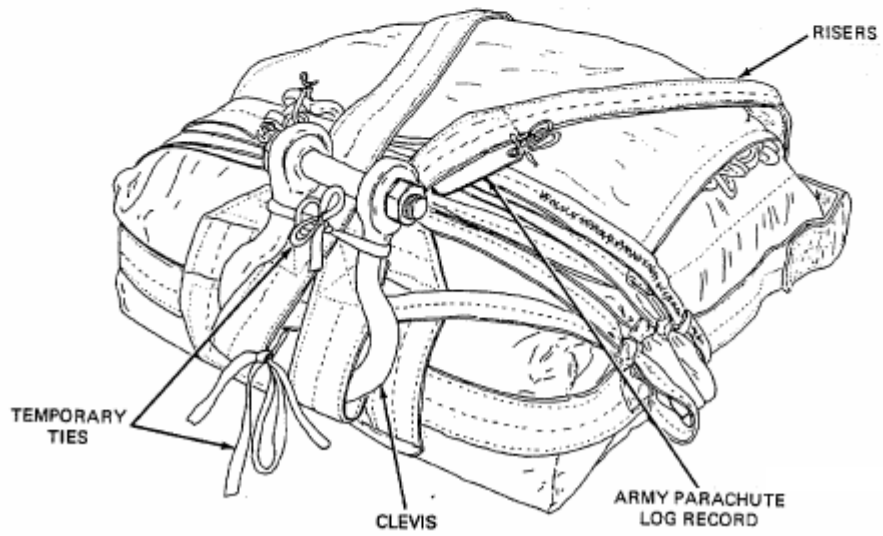

Figure 30. Parachute Pack Completed.



Figure 31. USL Static Line Stowed and Secured.

NOTE

Figure 32 shows the USL with temporary ties.



Figure 32. Parachute Pack Completed using USL, Breakaway.

END OF TASK

END OF WORK PACKAGE

**SERVICE MAINTENANCE
26-FOOT DIAMETER, HIGH-VELOCITY CARGO PARACHUTE ASSEMBLY
SEWING PROCEDURES**

INITIAL SETUP:**Tools**

Specified in paragraph applicable to the item being repaired.

References

WP 0014

Materials/Parts

Specified in paragraph applicable to the item being repaired.

Personnel Required

92R1P Parachute Rigger

Equipment Condition

Unpacked. Canopy with defects recorded. Clean.

NOTE

Sewing requirements will vary according to the type of item being repaired and the type of repair being made. The type of sewing machine, type of thread, the stitch range, and the stitch pattern (if applicable) required to accomplish a sewing procedure will be specified in the paragraph applicable to the item being repaired. All original stitching that is cut during the performance of a sewing procedure will be removed from the applicable item. Immediately after the accomplishment of a machine sewing procedure, trim thread ends to a point as close as possible to the material that has been sewn.

Repair and replacement of parachute components is performed in accordance with the repair instruction in this section and in specific paragraphs applicable to the item being repaired. Fabrication is a means of replacing an air delivery item component that is damaged beyond repair and not an issue item. Though the act of fabrication is a replacement-type action, the function is actually a method of repairing an end item. Since most fabrication pertains to components that are peculiar to parachutes, the fabrication of components that are most general in nature will be detailed in the following paragraph.

BASTING AND TEMPORARY TACKING

Basting and temporary tacking are hand-sewing methods used to temporarily hold layers of cloth fabric together while a repair is being performed. The following is a list of procedures that apply to basting and temporary tacking actions:

1. Basting and temporary tacking should be made using thread that is of a contrasting color to the material being worked.
2. Basting and temporary tacking will be performed using a single strand of size A, nylon thread, or ticket No. 24/4 cotton thread.
3. When basting, do not tie knots at any point in the thread length. Also, the basting should be made with two stitches per inch.
4. Immediately upon completion of a repair, remove previously made basting or temporary tacking.

END OF TASK

STITCHING AND RESTITCHING

Perform stitching and restitching as follows; refer to Tables 1 and 2.

1. Parachute canopy assemblies. The stitching and restitching made on parachute canopies should be accomplished with thread that is contrasting in color to the fabric being restitched. If contrasting color thread is not available, thread of matching color may be used, providing all other specifications are met. Straight stitching and restitching on parachute canopy assemblies should be locked by at least 2 inches at each end of a stitch row, when possible. Zig-Zag stitching does not require locking; however, zig-zag restitching should extend at least $\frac{1}{4}$ inch into undamaged stitching at each end, when possible. When restitching parachute canopy assemblies, stitch directly over the original stitching and follow the original stitch pattern as closely as possible.

Table 1. Sewing Machine Code Symbols.

CODE SYMBOL	SEWING MACHINE
LD	SEWING MACHINE, INDUSTRIAL: General Sewing; 301 Stitch; Light Duty; NSN 3530-01-177-8590.
MD ZZ	SEWING MACHINE, INDUSTRIAL: Zig-Zag; 308 Stitch; Medium Duty; NSN 3530-01-181-1421.
LD ZZ	SEWING MACHINE, INDUSTRIAL: Zig-Zag; 308 Stitch; Light Duty; NSN 3530-01-181-1420.
HD	SEWING MACHINE, INDUSTRIAL: General Sewing; 301 Stitch; Heavy Duty; NSN 3530-01-177-8588.
MD	SEWING MACHINE, INDUSTRIAL: General Sewing; 301 Stitch; Medium Duty; NSN 3530-01-177-8591.
DN	SEWING MACHINE, INDUSTRIAL: Darning; Lock Stitch; NSN 3530-01-177-8589.
LHD	SEWING MACHINE, INDUSTRIAL: 301 Stitch; Light-Heavy Duty; NSN 3530-01-186-3079.
ND	SEWING MACHINE, INDUSTRIAL: 301 Stitch; Double-Needle; NSN 3530-01-182-2873.

Table 2. Stitching and Restitching Specifications.

COMPONENT	RECOMMENDED SEWING MACHINE (CODE SYMBOL)	STITCHES PER INCH	THREAD SIZE
CANOPY			
Gore Section	LD DN	7 to 11 DARN	E E/A
Skirt Reinforcement Tape (lower lateral band)	LD	7 to 11	E
Radial Tape	LD	7 to 11	E
Suspension Line	MD ZZ	7 to 11	E
Bridle Loop	HD	5 to 8	6
Suspension Line	LD ZZ	7 to 11	E
Attaching loop	ZZ	7 to 11	E
Vent line	ZZ	7 to 11	E
Pocket band	ZZ	7 to 11	E
Riser	HD	5 to 8	3
Buffer	HD	5 to 8	3
Riser webbing	HD	5 to 8	3
Spreader	HD	5 to 8	3
Suspension line attaching loop	MD	7 to 11	E
Vent reinforcement tape (upper lateral band)	LD	7 to 11	E
Vertical tape	LD	7 to 11	E
DEPLOYMENT BAG			
Attaching loop	LD	7 to 11	E
Main strap	LD	7 to 11	E
Static line stow loop	LD	7 to 11	E
Stow loop retaining tie	LD	7 to 11	E
Protector flap tie loop	LD	7 to 11	E
Side main strap tie loop	LD	7 to 11	E
Panels and straps	LD	7 to 11	E
Static line	ZZ	7 to 11	FF

2. Other parachute items. Stitching and restitching on other parachute items constructed from cloth, canvas, and webbing should be accomplished with thread that matches the color of the original stitching, when possible. All straight stitching should be locked by backstitching at least $\frac{1}{2}$ inch. Restitching should be locked by overstitching each end of the stitch formation by $\frac{1}{2}$ inch. Zig-zag stitching does not require locking; however, zig-zag restitching should extend at least $\frac{1}{4}$ inch into undamaged stitching at each end, when possible. Restitching should be made directly over the original stitching; follow the original stitch pattern as closely as possible.

END OF TASK

DARNING

(Refer to Tables 1 and 2). Darning is a sewing procedure used to repair limited size holes, rips, and tears. A darning repair may be made either by hand or by sewing machine, depending upon the method preferred and the availability of equipment. However, a darning machine should be used to darn small holes and tears where fabric is missing. A darning repair will be performed using the following procedures, as appropriate:

1. Machine darning. Proceed as follows:
 - a. Using an authorized marking aid of contrasting color, mark a square around the damaged area and ensure the marking is at least $\frac{1}{4}$ -inch back from each edge of the damaged area.
 - b. Darn the damaged area by sewing the material in a back and forth manner, using size A or E nylon thread.
 - c. Turn the material and stitch back and forth across the stitching made in b., above, until the hole or tear is completely darned.

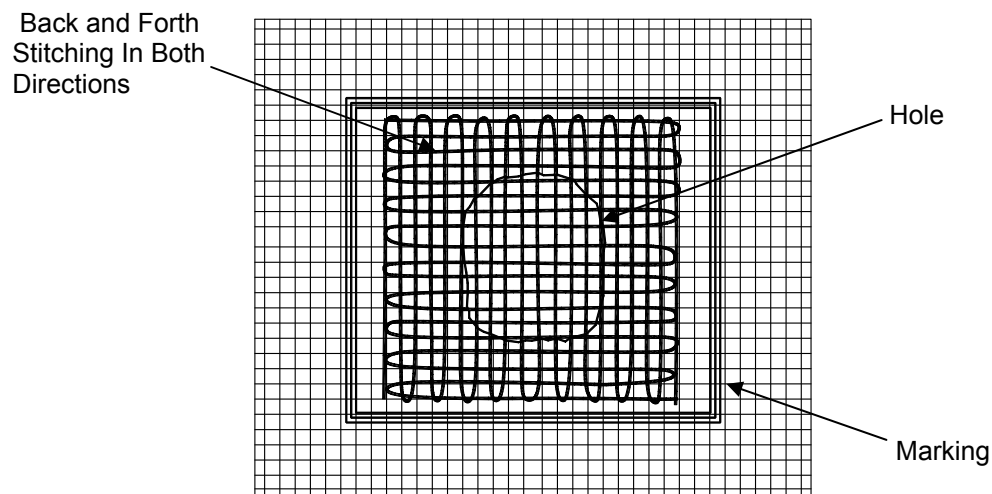

Figure 1. Machine Darning.

- d. If applicable, restencil informational data, gore number(s), or identification marks, using the criteria in WP 0014 00.

END OF TASK

2. Hand darning. When repair of a hole or tear is made by hand darning, the darn should match the original weave of the damaged material as closely as possible. Hand darning will be performed as follows:

- a. Using an authorized marking aid of contrasting color, mark a square around the damaged area and ensure the marking is at least $\frac{1}{4}$ -inch back from each edge of the damaged area.
- b. Using a darning needle and a length of size A or E nylon thread, begin darning at one corner of the marked area. Working parallel with the marking, pass the needle and thread back and forth through the material until the opposite diagonal corner of the marked area is reached.
- c. Turn the material and weave the needle and thread back and forth across the stitching made in b., above, until the hole is completely darned.

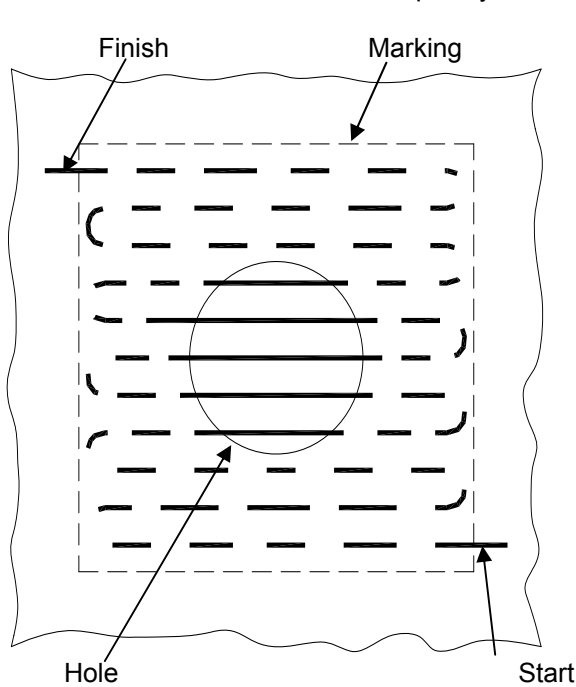

Figure 2. Hand Darning.

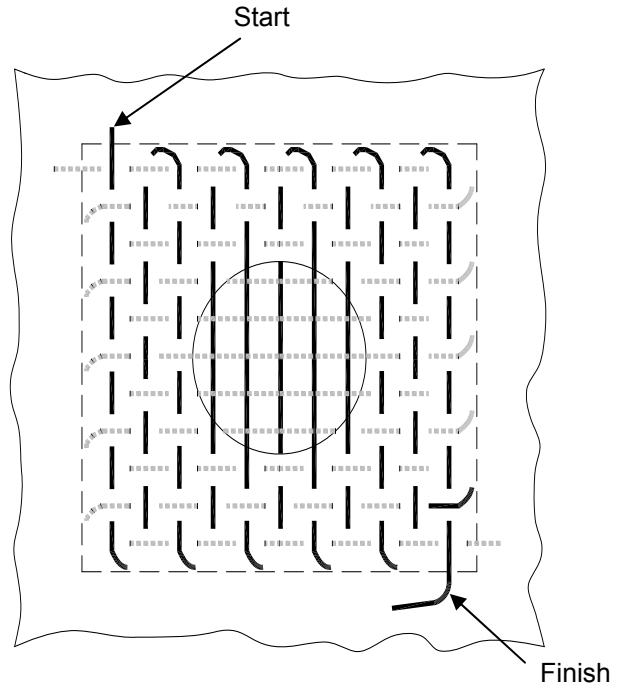

Figure 3. Hand Darning Completed.

- d. If applicable, restencil informational data or identification marks as outlined in WP 0014.

END OF TASK

ZIG-ZAG SEWING

(Refer to Tables 1 and 2). Components of the 26-Foot Diameter, High-Velocity Cargo Parachute, except the parachute canopy, that have sustained cut or tear damage, may be repaired by zig-zag sewing, provided the applicable damaged area does not have any material missing and the cut or tear is straight or L-shaped. Should the damaged area be irregular shaped or have material missing, the repair will be achieved by either darning or patching, as required. A zig-zag sewing repair will be accomplished using a zig-zag sewing machine, with the following procedures:

1. Set the sewing machine to the maximum stitch width.
2. Beginning at a point $\frac{1}{4}$ -inch beyond one end of the cut or tear, stitch lengthwise along the damaged area to a point $\frac{1}{4}$ -inch beyond the opposite end of the cut or tear.



Figure 4. Straight cut or Tear Stitching.

3. The cited stitching procedure will also apply to an L-shaped cut or tear.

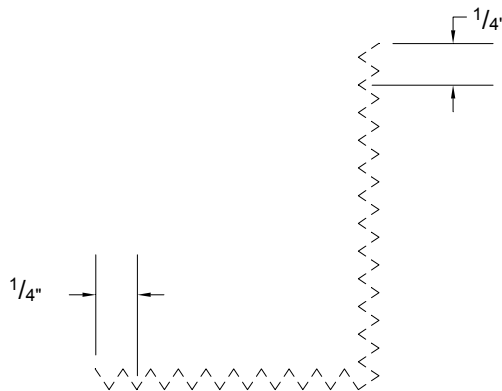

Figure 5. L-Shaped Cut or Tear Stitching.

4. If applicable, restencil informational data or identification marks as prescribed in WP 0014.

END OF TASK

END OF WORK PACKAGE

**SERVICE MAINTENANCE
26-FOOT DIAMETER, HIGH-VELOCITY CARGO PARACHUTE ASSEMBLY
SEARING AND WAXING**

INITIAL SETUP:**Tools**

Pot, Melting, Electric (WP 0049, Item 12)
Knife, Hot Metal (WP 0049, Item 6)

Personnel Required

92R1P Parachute Rigger

Materials/Parts

Beeswax, Technical, 1 lb. (WP 0050, Item 2)
Wax, Paraffin (WP 0050, Item 40)

Equipment Condition

Unpacked.

CAUTION

Cotton tape, webbing, or cord will not be seared.

NOTE

Fabric materials such as cord, tape, and webbing, that are cut for use in the maintenance of the 26-Foot Diameter, High-Velocity Cargo Parachute, will normally be heat-seared or dipped in a melted wax mixture, as applicable, to prevent the material from fraying or unraveling. However, in some instances, the preparation of the material may not be necessary and will be specified accordingly.

SEARING

The cut ends of nylon tape, webbing and cord lengths may be prepared by heat-searing, which is performed by pressing the raw end of the material against a hot metal surface (knife) until the nylon has melted sufficiently. Avoid forming a sharp edge or lumped effect on the melted end.

END OF TASK**WAXING**

The fraying or unraveling of cotton or nylon tape, webbing, and cord length ends may be prevented by dipping ½ inch of the raw end of the material into a thoroughly melted mixture of half beeswax and half paraffin in an electric melting pot. The wax temperature should be substantial enough to ensure the wax completely penetrates the material, rather than just coating the exterior fabric.

END OF TASK**END OF WORK PACKAGE**

**SERVICE MAINTENANCE
26-FOOT DIAMETER, HIGH-VELOCITY CARGO PARACHUTE ASSEMBLY
MARKING AND RESTENCILING**

INITIAL SETUP:**Tools**

Machine, Stencil Cutting (WP 0049, Item 8)

Materials/Parts

Brush, Stenciling (WP 0050, Item 4)
Ink, Marking (WP 0050, Item 16)
Marker, Felt Tip, Blue (WP 0050, Item 18)
Pen, Ballpoint (WP 0050, Item 20)
Stencilboard, Oiled (WP 0050, Item 26)

Personnel Required

92R1P Parachute Rigger

Equipment Condition

Laid out on packing table or other suitable area.

NOTE

Stenciling should be used whenever possible. A ballpoint pen or felt tip marker should be used only where stenciling is not possible, or when stenciling devices are not available. Any type ballpoint pen, using black or blue ink, may be used for marking on labels only.

Original stenciled data label or marking that becomes faded, illegible, obliterated, or removed as a result of performing a repair procedure, will be remarked with a ballpoint pen, felt tip marker, or restenciled. All marking or restenciling will be done on, or as near as possible to, the original location and should conform to the original lettering type and size.

MARKING

Using marking devices, such as a ballpoint pen or felt tip marker, mark on, or as near as possible to, the original location and conform to the original lettering type and size.

END OF TASK**RESTENCILING**

Proceed as follows:

1. Cut oiled stencilboard to match the original lettering type and size of data to be restenciled.
2. Place cut stencilboard over, or as near as possible to, the original marking to be restenciled.
3. Place an additional sheet of stencilboard beneath the area to be restenciled to prevent the marking ink from penetrating to other areas.
4. Hold the stencilboard in place and, using the stenciling brush filled with parachute marking ink, restencil the original marking.

END OF TASK

REMARKING AND RESTENCILING

Remark/restencil the original stenciled data/markings that become faded, illegible, obliterated, or that have been removed as a result of performing a repair procedure. Ensure all marking/restenciling is on, or as near as possible to, the original location and conforms to the original lettering type and size.

END OF TASK**END OF WORK PACKAGE**

SERVICE MAINTENANCE
26-FOOT DIAMETER, HIGH-VELOCITY CARGO PARACHUTE ASSEMBLY
BRIDLE LOOP
REPAIR, REPLACE

INITIAL SETUP:**Tools**

Sewing Machine, Heavy-Duty
 (WP 0049, Item 17)
 Shears (WP 0049, Item 13)
 Pot, Melting, Electric (WP 0049, Item 12)

Materials/Parts

Thread, Nylon, Size 6 (WP 0050, Items 38/39)
 Webbing, Cotton, Type VIII (WP 0050, Item 43)
 Beeswax, Technical, 1 lb (WP 0050, Item 2)
 Wax, Paraffin (WP 0050, Item 40)

Personnel Required

92R1P Parachute Rigger

References

WP 0009
 WP 0013

Equipment Condition

Inspected (WP 0006)
 Cleaned (WP 0008)
 Shaken out (WP 0007)
 Unpacked, canopy laid flat.

REPAIR

Repair a bridle loop, requiring restitching as follows:

1. Use a heavy-duty sewing machine to restitch any loose or broken stitches.
2. Restitch over original stitch pattern using nylon thread, size 6. Overstitch $\frac{1}{2}$ inch to lock stitches.

END OF TASK**REPLACE**

Replace a damaged or missing bridle loop by fabricating as follows:

1. Cut a 10-inch length of cotton webbing, Type VIII. Wax ends of webbing (WP 0013).
2. Pass one end of webbing around all canopy vent lines. Join both webbing ends together with a 2-inch overlap (Figure 1).
3. Begin at a point $\frac{1}{4}$ inch from one overlapped webbing end. Use a heavy-duty sewing machine to secure overlapped ends. With nylon thread, size 6, stitch a $1\frac{1}{2}$ -inch long, single Box X stitch, 5 to 8 stitches per inch.
4. Cut and remove damaged bridle loop.

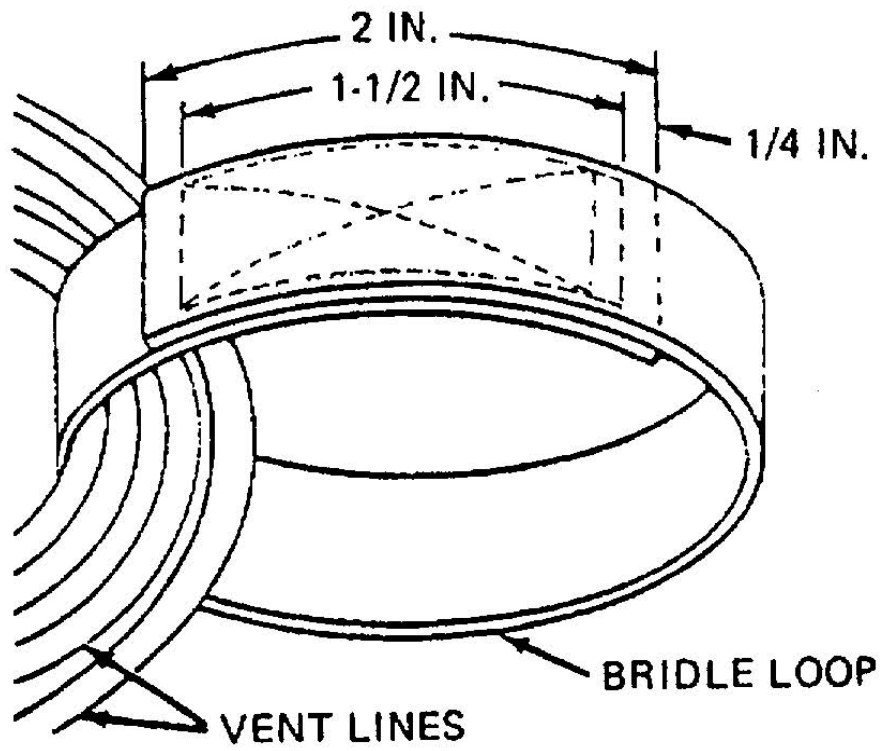

Figure 1. Bridle Loop Replacement Details.

END OF TASK

END OF WORK PACKAGE

SERVICE MAINTENANCE
26-FOOT DIAMETER, HIGH-VELOCITY CARGO PARACHUTE ASSEMBLY
VENT LINES
REPAIR, REPLACE

INITIAL SETUP:**Tools**

Knife (WP 0049, Item 5)
 Knife, Hot Metal (WP 0049, Item 6)
 Sewing Machine, Zig-Zag (WP 0049, Item 15)
 Yardstick (WP 0049, Item 22)

Personnel Required

92R1P Parachute Rigger

Materials/Parts

Cord, Nylon, Type II, Coreless OD (WP 0050, Item 13)
 Pencil, Marking Aid (WP 0050, Items 21/22)
 Thread, Nylon, Size E (WP 0050, Items 33/34)

Equipment Condition

Inspected (WP 0006)
 Cleaned (WP 0008)
 Shaken out (WP 0007)
 Unpacked, canopy in proper layout.

References

WP 0013

REPAIR

Repair vent lines, requiring restitching as follows:

1. Use a zig-zag sewing machine to restitch any loose or broken stitches.
2. Restitch over original stitch pattern using nylon thread, size E. Overstitch ½ inch to lock stitches.

END OF TASK**REPLACE**

Replace a damaged or missing vent line as follows:

1. Place canopy in proper layout on table and trace damaged vent line from one end of original vent line to other end. Using suitable marker, mark canopy at each end of vent line.
2. Remove damaged vent line by cutting stitching that holds line to canopy at both sides of apex.
3. Cut a 14-inch length of Type II nylon cord. Sear or dip ends of cord (WP 0013).
4. Position one end of new vent line in exact location formerly occupied by end of old line (Figure 1).

5. Using a zig-zag sewing machine and nylon thread, size E, stitch new line place. Begin stitching on Line $\frac{1}{4}$ -inch above upper edge of upper lateral band and sew to $\frac{1}{4}$ -inch beyond end of line, 7 to 11 stitches per inch and $\frac{1}{8}$ -inch wide (Figure 1).
6. Pass remaining end of line under other vent lines and through the bridle loop as required.
7. Position and sew remaining end of line to opposite side of canopy as in steps (4) and (5) above.

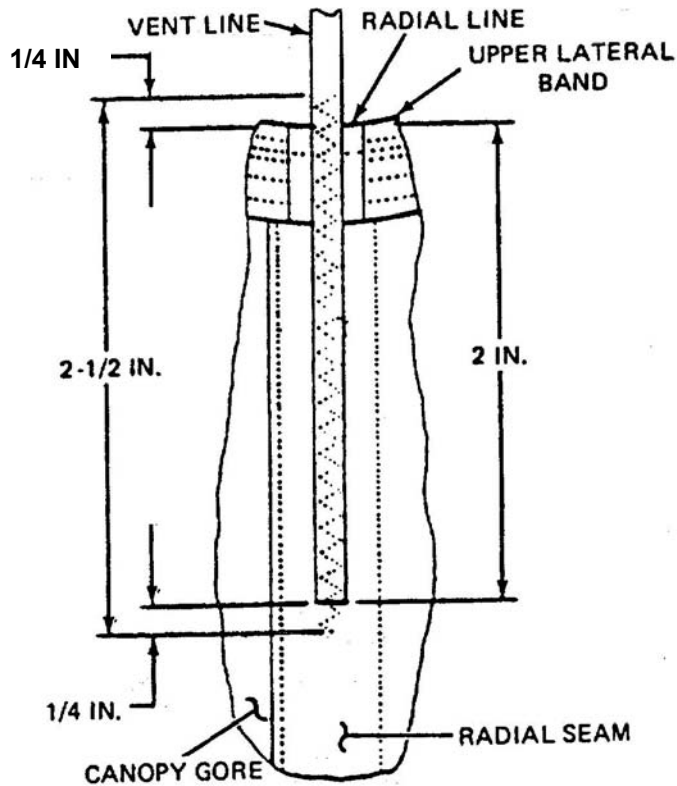

Figure 1. Vent Line Replacement Details.

END OF TASK

END OF WORK PACKAGE

SERVICE MAINTENANCE
26-FOOT DIAMETER, HIGH-VELOCITY CARGO PARACHUTE ASSEMBLY
VENT REINFORCEMENT TAPE (UPPER LATERAL BAND)
REPAIR

INITIAL SETUP:**Tools**

Shears (WP 0049, Item 13)
 Knife, Hot Metal (WP 0049, Item 6)
 Sewing Machine, Light-Duty (WP 0049, Item 14)
 Yardstick (WP 0049, Item 21)
 Sewing Machine, Zig-Zag (WP 0049, Item 15)

Personnel Required

92R1P Parachute Rigger

Materials/Parts

Pencil, Marking Aid (WP 0050, Items 21/22)
 Tape, Nylon, Type III, 3/4 Inch (WP 0050, Item 29)
 Thread, Nylon, Size E (WP 0050, Items 33/34)

Equipment Condition

Inspected (WP 0006)
 Cleaned (WP 0008)
 Shaken (WP 0007)
 Unpacked, canopy laid flat.

References

WP 0013
 WP 0016

REPAIR

1. Restitching. Restitching of vent reinforcement tape is authorized. Use a light-duty sewing machine and Size E nylon thread of contrasting color. Stitch over the original stitch pattern. Lock each row of stitches two inches at each end.

NOTE

Vent reinforcement tapes may be spliced only once and will never be replaced.

2. Damage Between Radial Seams. Repair as follows:
 - a. Mark vent line position and cut stitching of two vent lines on each side of damaged area. Move lines to one side.
 - b. Smooth canopy around damaged area.
 - c. Cut a piece of 3/4-inch nylon tape, long enough to extend 1 inch beyond outside edge of second radial seam on each side of damaged area. Sear or dip ends of tape (WP 0013).
 - d. Position webbing on damaged area. Use a light-duty sewing machine and size E nylon thread to stitch. Sew webbing in place with two continuous rows of stitching 1/8 inch from edge of tape, 7 to 11 stitches per inch. Overstitch ends of webbing 2 inches (Figure 1, A).
 - e. Reposition vent lines and sew them in place according to marks made earlier with a zig-zag sewing machine (WP 0016).

-
3. Damage Extending into Radial Seam. Repair as follows:
- a. Mark vent line position and cut stitching of vent line attached to damaged radial seam and the stitching of two vent lines on each side of damaged seam. Move lines to one side.
 - b. Smooth canopy around damaged area.
 - c. Cut a piece of $\frac{3}{4}$ -inch nylon tape long enough to extend 1 inch beyond outside edge of second radial seam on each side of damaged area. Sear or dip ends of tape (WP 0013).
 - d. Position tape on damaged area. Use a light-duty sewing machine and size E nylon thread to stitch. Sew webbing in place with two continuous rows of stitching, $\frac{1}{8}$ inch from edge of tape, 7 to 11 inches per stitch. Overstitch ends of tape two inches (Figure 1, B).
 - e. Reposition vent lines and sew in place according to marks made earlier with a zig-zag sewing machine (WP 0016).

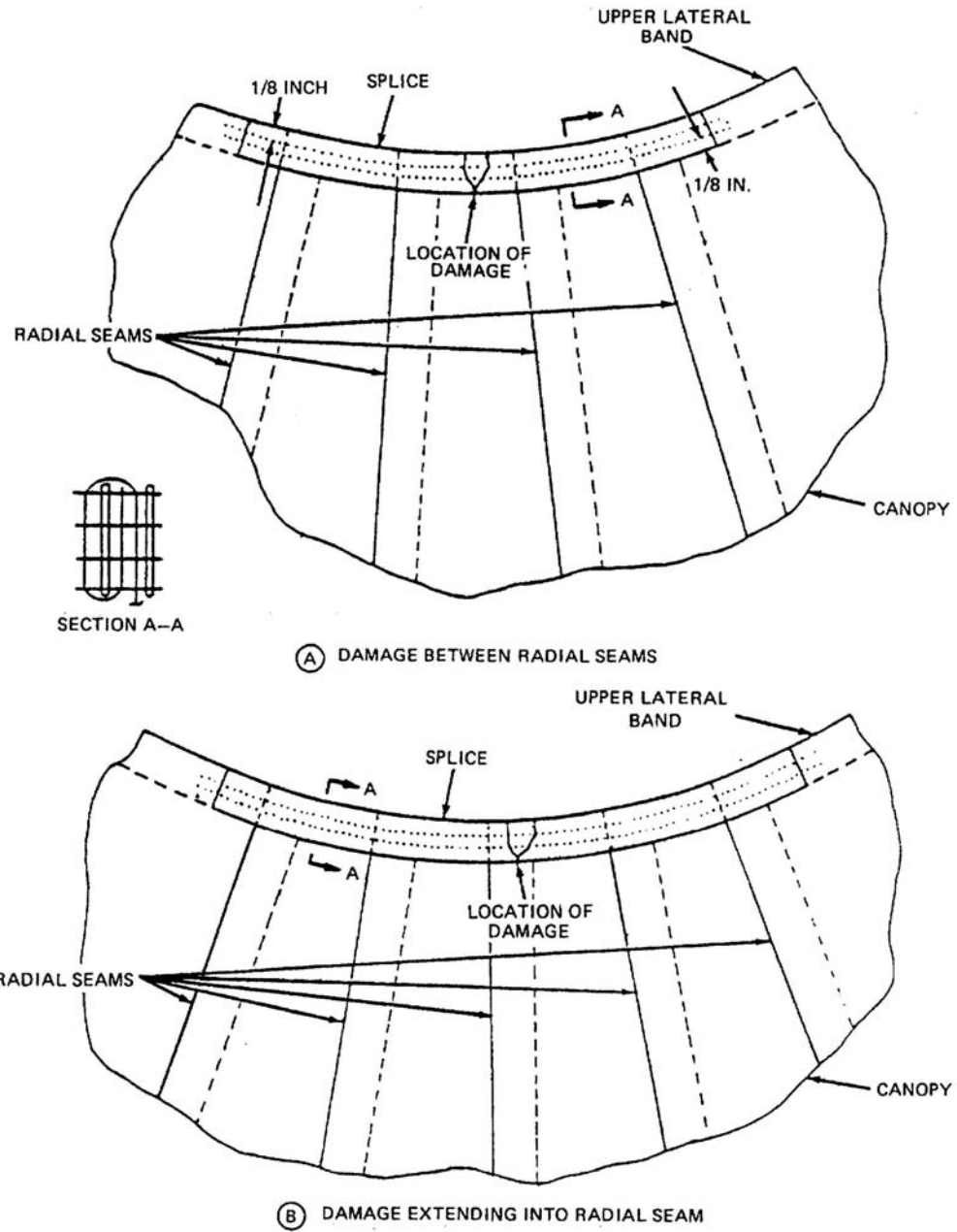

Figure 1. Vent Reinforcement Tape Splicing Details.

END OF TASK

END OF WORK PACKAGE

SERVICE MAINTENANCE
26-FOOT DIAMETER, HIGH-VELOCITY CARGO PARACHUTE ASSEMBLY
RADIAL TAPE
REPAIR

INITIAL SETUP:**Tools**

Shears (WP 0049, Item 13)
Knife, Hot Metal (WP 0049, Item 6)
Sewing Machine, Light-Duty (WP 0049, Item 14)
Yardstick (WP 0049, Item 22)

Materials/Parts

Tape, Nylon, Type III, 3/4 Inch (WP 0050, Item 29)
Thread, Nylon, Size E (WP 0050, Items 33/34)
Pencil, Marking Aid (WP 0050, Items 21/22)

Personnel Required

92R1P Parachute Rigger

Equipment Condition

Inspected (WP 0006)
Cleaned (WP 0008)
Shaken (WP 0007)
Unpacked, laid flat.

References

WP 0013

REPAIR

1. Restitching. Restitch radial tape. Use a light-duty sewing machine and size E nylon thread of contrasting color. Stitch over original pattern. Lock each row of stitches two inches at each end.
2. Splicing. Splice damaged radial tape as follows:
 - a. Place canopy on a repair table with damaged side of radial tape facing up and smooth out canopy material in affected area.

NOTE

There is no limit to the number of splices that may be made on radial tape. When splicing an area previously spliced, remove old splice material before attempting a second splice.

- b. Cut a length of 3/4-inch wide nylon tape long enough to extend 4 inches beyond each side of damaged area and sear ends as specified in WP 0013.
 - c. Center tape length over damaged area. Using a light-duty sewing machine and size E nylon thread, secure splice by stitching a box-stitch formation along full length of splice (Figure 1).

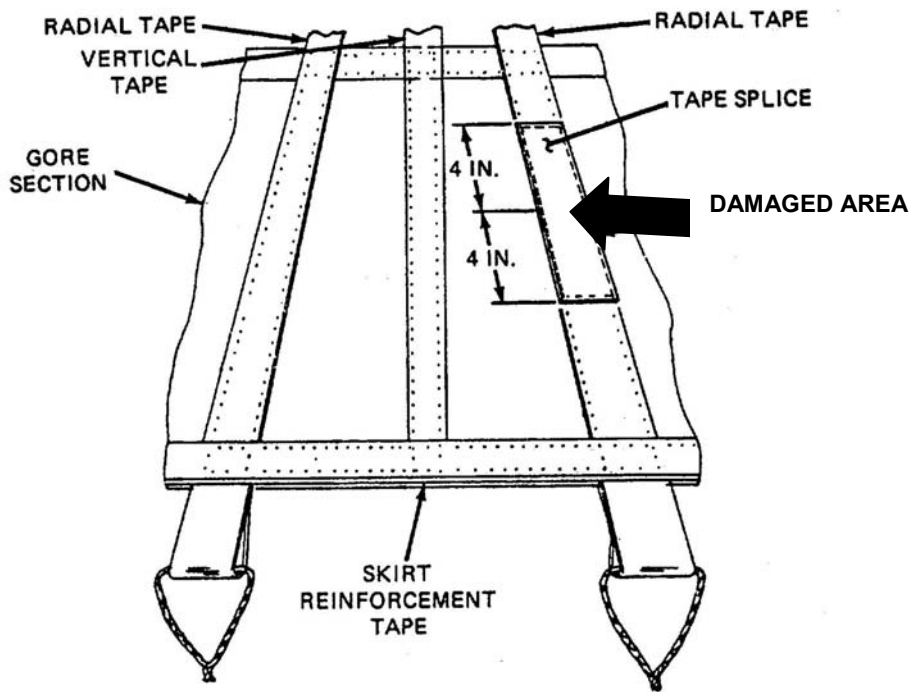

Figure 1. Radial Tape Splicing Details.

END OF TASK

END OF WORK PACKAGE

SERVICE MAINTENANCE
26-FOOT DIAMETER, HIGH-VELOCITY CARGO PARACHUTE ASSEMBLY
VERTICAL TAPE
REPAIR

INITIAL SETUP:**Tools**

Shears (WP 0049, Item 13)
Knife, Hot Metal (WP 0049, Item 6)
Sewing Machine, Light-Duty (WP 0049, Item 14)
Yardstick (WP 0049, Item 22)

Personnel Required

92R1P Parachute Rigger

Materials/Parts

Pencil, Marking Aid (WP 0050, Items 21/22)
Tape, Nylon, Type III, ½ Inch (WP 0050, Item 28)
Thread, Nylon, Size E (WP 0050, Items 33/34)

Equipment Condition

Inspected (WP 0006)
Cleaned (WP 0008)
Shaken (WP 0007)
Laid out on work table.

References

WP 0012
WP 0013

REPAIR

1. Stitching. Stitch and restitch (WP 0012) with thread size E nylon which matches the color of the original stitching, when possible. Lock all straight stitching by backstitching at least ½ inch. Restitch directly over the original stitch, following the original stitch pattern as closely as possible.
2. Splicing. Splice vertical tape as follows:

NOTE

There is no limit to the number of splices allowed on the vertical tape.

- a. Measure a length of ½ -inch wide nylon tape long enough to extend 4 inches beyond each side of damaged area.
- b. Double measurement; cut and sear ends (WP 0013).
- c. Center doubled tape length over damaged area. (Figure 1.)
- d. Using a light-duty sewing machine and size E nylon thread, secure splice by stitching a box-stitch formation the full length of splice material. Stitching will be ⅛ inch from edges of splice material, 7 to 11 stitches per inch.

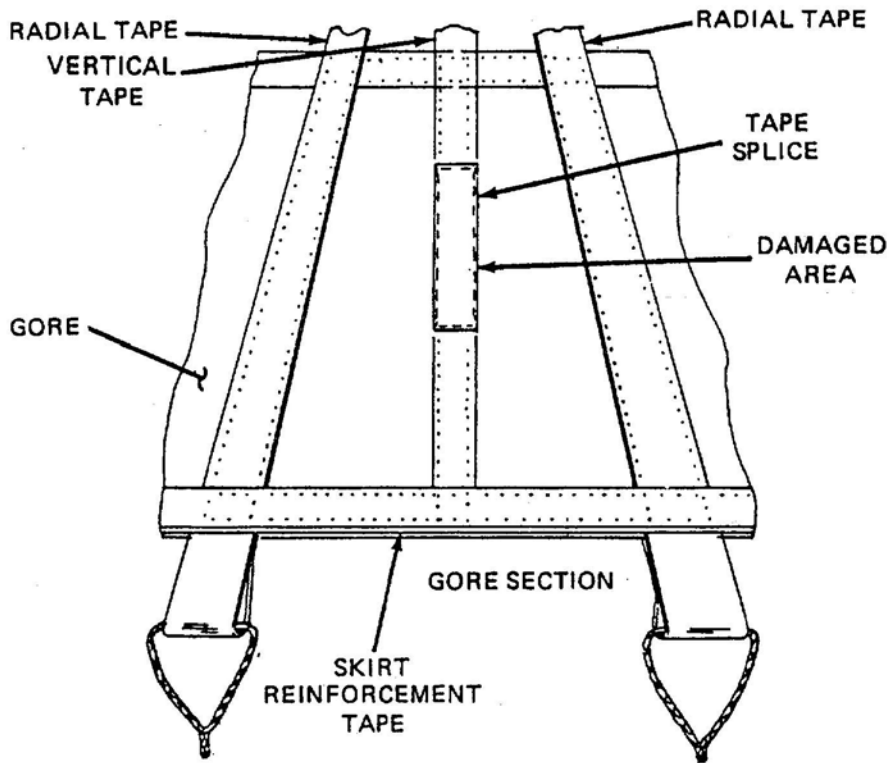

Figure 1. Vertical Tape Splicing Details.

END OF TASK

END OF WORK PACKAGE

SERVICE MAINTENANCE
26-FOOT DIAMETER, HIGH-VELOCITY CARGO PARACHUTE ASSEMBLY
SKIRT REINFORCEMENT TAPE (LOWER LATERAL BAND)
REPAIR

INITIAL SETUP:**Tools**

Shears (WP 0049, Item 13)
 Knife, Hot Metal (WP 0049, Item 6)
 Sewing Machine, Light-Duty (WP 0049, Item 14)
 Sewing Machine, Zig-Zag (WP 0049, Item 15)
 Yardstick (WP 0049, Item 22)

Personnel Required

92R1P Parachute
 Rigger

Materials/Parts

Tape, Nylon, Type III, 3/4 IN (WP 0050, Item 29)
 Thread, Nylon, Size E (WP 0050, Items 33/34)

Equipment Condition

Inspected (WP 0006)
 Cleaned (WP 0008)
 Shaken (WP 0007)
 Unpacked, lying flat on
 repair table.

References

WP 0012
 WP 0013
 WP 0021

REPAIR**NOTE**

The skirt reinforcement tape may have one splice between any suspension lines and cannot be replaced.

If the damage is located in a previously spliced area between two suspension lines, the earlier made splice material will be removed before attempting a second splice repair.

1. Restitching. Restitching of vent reinforcement tape is authorized. Use a light-duty sewing machine and Size E nylon thread of contrasting color. Stitch over the original stitch pattern. Lock each row of stitches two inches at each end.
2. Splicing. Splice the skirt reinforcement tape as follows:
 - a. With damaged side of skirt reinforcement tape facing up, smooth out affected area of canopy. Remove previous splice, if required.
 - b. As required, cut and remove original stitching which secures pocket band end to skirt reinforcement tape. Fold pocket band loose end away from repair area.
 - c. Cut a length of 3/4-inch wide nylon tape long enough to extend 6 inches beyond each side of damaged area. Sear each end of tape (WP 0013).
 - d. Center tape length over damaged area (Figure 1) and secure splice by making four rows of continuous stitching using a light-duty sewing machine and size E thread. Overstitch each webbing end by 1/2 inch. Stitching will be 7 to 11 stitches per inch.

e. Using a zig-zag sewing machine and size E nylon thread, reinstall pocket band loose end in original location with a two-inch long, 1/4-inch wide row of stitching. Stitching will be 7 to 11 stitches per inch (WP 0012).

3. Replace pocket band, if required (WP 0021).

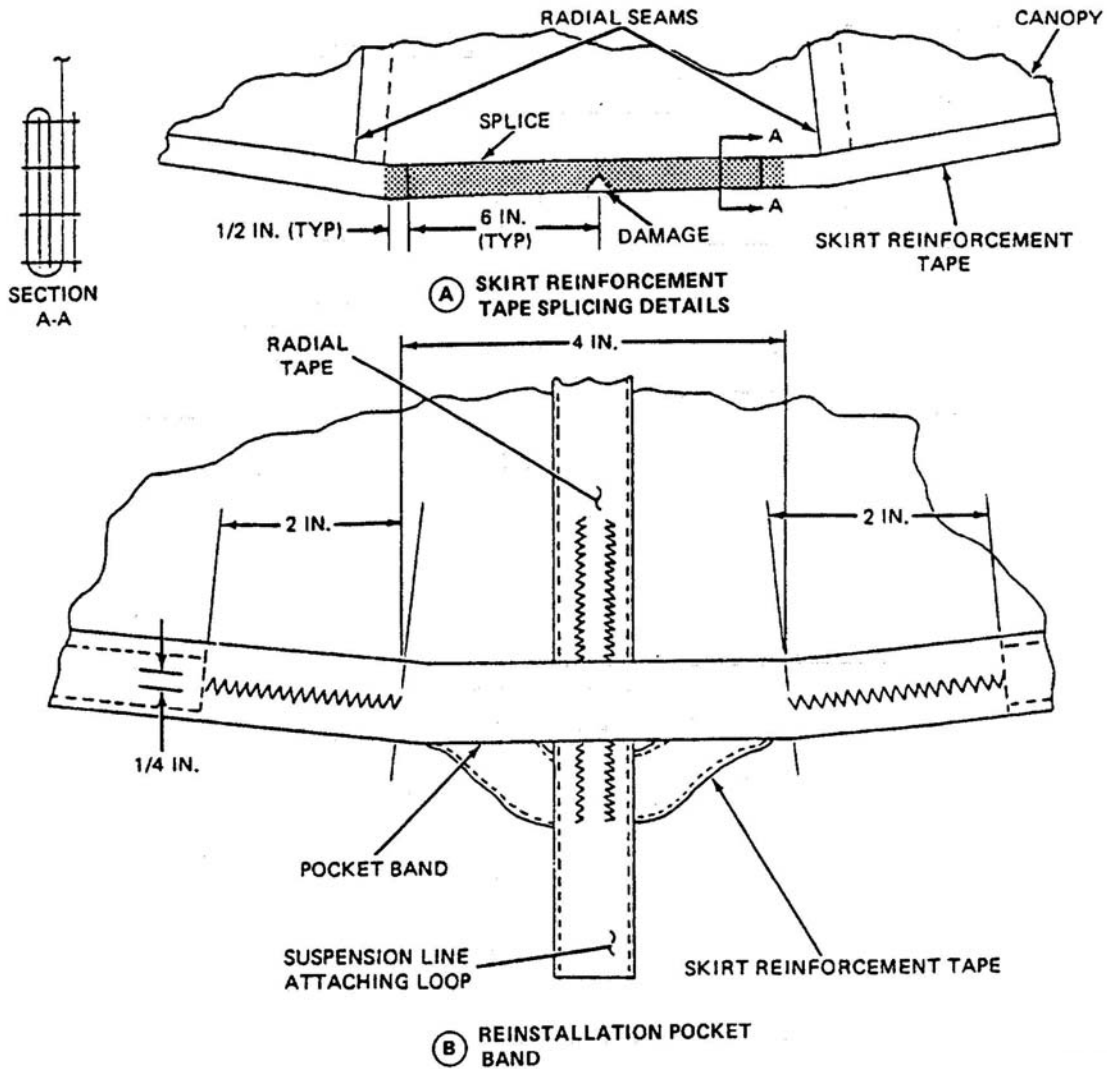

Figure 1. Skirt Reinforcement Tape Splicing Details.

END OF TASK

END OF WORK PACKAGE

SERVICE MAINTENANCE
26-FOOT DIAMETER, HIGH-VELOCITY CARGO PARACHUTE ASSEMBLY
POCKET BAND
REPAIR

INITIAL SETUP:**Tools**

Shears (WP 0049, Item 13)
Knife, Hot Metal (WP 0049, Item 6)
Sewing Machine, Zig-Zag (WP 0049, Item 15)
Yardstick (WP 0049, Item 22)

Personnel Required

92R1P Parachute Rigger

Materials/Parts

Pencil, Marking Aid (WP 0050, Items 21/22)
Tape, Nylon, Type III, 3/4 IN (WP 0050, Item 29)
Thread, Nylon, Size E (WP 0050, Items 33/34)

Equipment Condition

Inspected (WP 0006)
Cleaned (WP 0008)
Shaken (WP 0007)
Unpacked, lying flat on repair table.

References

WP 0012
WP 0013

REPAIR

Repair. Stitch and restitch (WP 0012) with nylon thread, size E, which matches the color of the original stitching, when possible. Lock all zig-zag stitching by over stitching at least 1/2 inch. Restitch directly over the original stitch pattern, following the original stitch pattern as closely as possible.

END OF TASK**REPLACEMENT**

1. Replacement. Replace an unserviceable pocket band by fabricating as follows:
 - a. Using a suitable marking aid, mark canopy at each end of original pocket band.
 - b. Cut stitching on both ends of the original pocket band and remove pocket band from canopy skirt.
 - c. Cut an 8-inch length of 3/4-inch wide nylon tape. Sear ends (WP 0013).
 - d. Using a zig-zag sewing machine and size E nylon thread, secure each end of replacement pocket band with a two-inch long, 1/4-inch wide row of stitching. Stitching will be 7 to 11 stitches per inch (Figure 1).

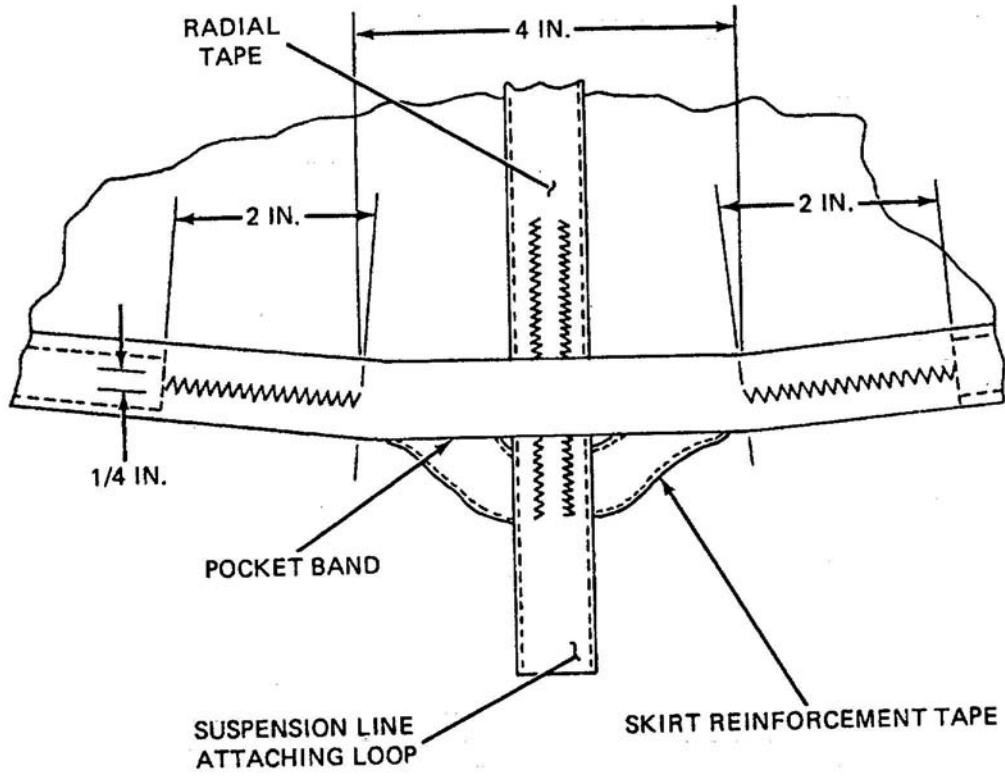

Figure 1. Pocket Band Replacement Details.

END OF TASK

END OF WORK PACKAGE

SERVICE MAINTENANCE
26-FOOT DIAMETER, HIGH-VELOCITY CARGO PARACHUTE ASSEMBLY
SUSPENSION LINE ATTACHING LOOP
REPAIR

INITIAL SETUP:**Tools**

Knife (WP 0049, Item 5)
Knife, Hot Metal (WP 0049, Item 6)
Sewing Machine, Light-Duty (WP 0049, Item 14)
Sewing Machine, Zig-Zag (WP 0049, Item 15)
Yardstick (WP 0049, Item 22)

Personnel Required

92R1P Parachute Rigger

Materials/Parts

Pencil, Marking Aid (WP 0050, Items 21/22)
Thread, Nylon, Size E (WP 0050, Items 33/34)
Tape, Nylon, Type III, 3/4 IN (WP 0050, Item 29)

Equipment Condition

Inspected (WP 0006)
Cleaned (WP 0008)
Shaken (WP 0007)
Canopy laid out on table.

References

WP 0012
WP 0035
WP 0049

REPAIR

Stitch and restitch (WP 0012) with thread which matches the color of the original stitching, when possible. Lock all straight stitching by overstitching at least 1/2 inch. Restitch directly over the original stitching, following the original stitch pattern as closely as possible.

NOTE

Replacement of suspension line attaching loop is accomplished at the Sustainment Level, in accordance with the Maintenance Allocation Chart (MAC), WP 0049. See WP 0035 for replacement instructions.

END OF TASK**END OF WORK PACKAGE**

SERVICE MAINTENANCE
26-FOOT DIAMETER, HIGH-VELOCITY CARGO PARACHUTE ASSEMBLY
SUSPENSION LINE
REPAIR

INITIAL SETUP:**Tools**

Knife (WP 0049, Item 5)
 Knife, Hot Metal (WP 0049, Item 6)
 Sewing Machine, Zig-Zag (WP 0049, Item 15)
 Splicing Aid (WP 0049, Item 23)
 Yardstick (WP 0049, Item 22)
 Machine, Stencil Cutting (WP 0049, Item 8)

Personnel Required

92R1P Parachute Rigger

Materials/Parts

Cord, Nylon, Type II Coreless (WP 0050, Item 13)
 Thread, Nylon, Size E (WP 0050, Items 33/34)

Equipment Condition

Inspected (WP 0006)
 Cleaned (WP 0008)
 Shaken (WP 0007)
 Canopy laid flat on repair table.

References

WP 0049

REPAIR

Repair a suspension line using the following procedures:

1. Restitching. Stitch and restitch with thread, nylon, size E, that is contrasting in color to the fabric being stitched or original thread being restitched. If contrasting color thread is not available, thread of matching color may be used, providing all other specifications are met. Straight stitching and restitching should be locked by at least two inches at each end of a stitch row when possible. Zig-zag restitching should extend at least $\frac{1}{4}$ inch into undamaged stitching at each end, when possible. Restitch directly over the original stitching, following the original stitch pattern as closely as possible.
2. Splicing. A suspension line may be spliced one time as follows:

NOTE

Splicing of the line on the 26-ft cargo parachute (high velocity) is an exception to the splicing of coreless cord.

- a. Cut a length of coreless nylon cord long enough to extend 3 inches beyond each side of damaged area. Sear or wax each end of cord $\frac{1}{2}$ inch.
- b. Center cord length over damaged area. Using a zig-zag sewing machine and size E nylon thread, secure splice by stitching a $\frac{3}{16}$ -inch wide row of stitching full length of splice, extending stitching $\frac{1}{2}$ inch beyond each end (Figure 1). Stitching will be 7 to 11 stitches per inch.

NOTE

Replacement of suspension lines is accomplished at the Intermediate (Field) Maintenance Level only, in accordance with the Maintenance Allocation Chart (MAC), WP 0049.

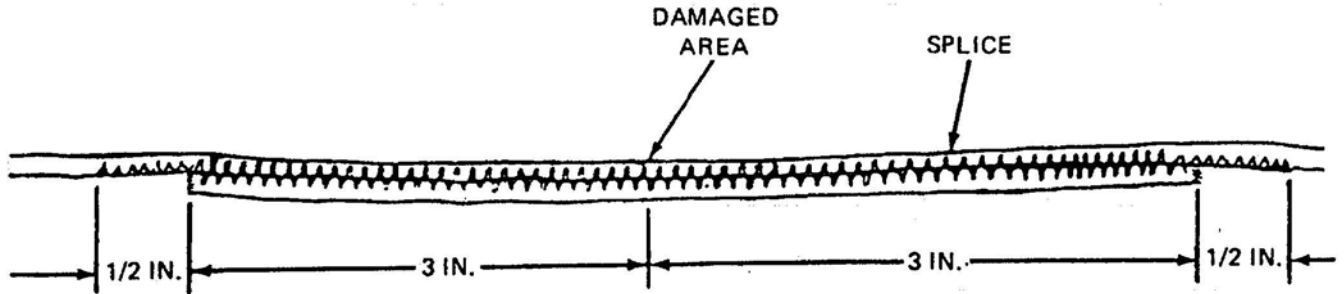

Figure 1. Suspension Line Splicing Details.

END OF TASK

END OF WORK PACKAGE

SERVICE MAINTENANCE
26-FOOT DIAMETER, HIGH-VELOCITY CARGO PARACHUTE ASSEMBLY
RISER
REPAIR, REPLACE

INITIAL SETUP:**Tools**

Knife (WP 0049, Item 5)
 Knife, Hot Metal (WP 0049, Item 6)
 Pot, Melting, Electric (WP 0049, Item 12)
 Sewing Machine, Heavy-Duty (WP 0049, Item 17)
 Yardstick (WP 0049, Item 22)

Personnel Required

92R1P Parachute Rigger

Equipment Condition

Inspected (WP 0006)
 Cleaned (WP 0008)
 Shaken (WP 0007)
 Unpacked, laid flat on
 repair table.

Materials/Parts

Beeswax, Technical, 1 LB (WP 0050, Item 2)
 Pencil, Marking Aid (WP 0050, Items 21/22)
 Tape, Pressure Sensitive, 1 Inch (WP 0050, Item 30)
 Thread, Nylon, Size 3 (WP 0050, Items 36/37)
 Webbing, Cotton, Type I ¼ Inch (WP 0050, Item 41)
 Webbing, Nylon, Type VIII (WP 0050, Item 44)
 Webbing, Cotton, Type VIII (WP 0050, Item 43)
 Wax, Paraffin, Technical (WP 0050, Item 40)

References

WP 0003
 WP 0012
 WP 0013
 WP 0014
 WP 0036

REPAIR

1. Stitching. Stitch and restitch with thread, nylon, size 3, which matches the color of the original stitching, if possible. Lock all straight stitching by backstitching at least ½ inch. Restitch directly over the original stitching, following the original stitch pattern as closely as possible.
2. Retaping attachment loop. Before retaping, ensure remains of all original tape have been removed. Retape rolled portion of suspension line attaching loop using five spiral turns of 1-inch wide, pressure sensitive tape (Figure 1).
3. Restencil. As required, restencil identification marking using procedures in WP 0014.

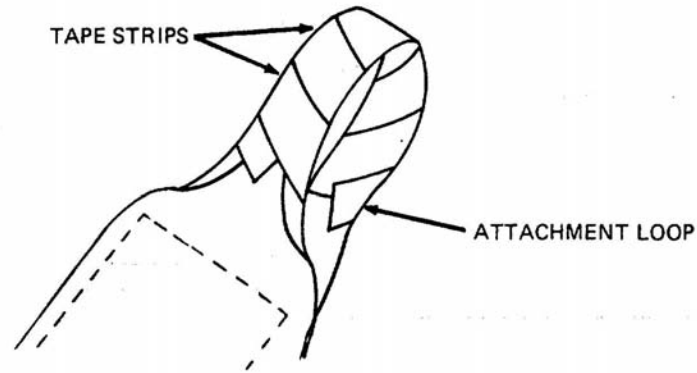

Figure 1. Retaping Attaching Loop.

4. Splicing. Each of the two riser straps and the spreader may be spliced one time as follows:

NOTE

Splicing will be performed on a left riser when the damaged area extends into the parachute inspection data pocket (log record pocket). When this occurs, a log record pocket from stock will be installed in this location in accordance with procedures in WP 0003.

- a. Cut a length of 1 23/32-inch wide Type VIII nylon webbing long enough to extend 4 inches beyond each side of damaged area and sear ends (WP 0013).
- b. Center webbing length over damaged area (Figure 2). Using a heavy-duty Sewing machine and size 3 nylon thread, secure each end of splice by stitching a 3-inch long, four-point WW stitch formation, 1/8 inch in from each side edge of splice material. Overstitch each end of splice material by one stitch on each point of stitch formation. Stitching shall be 5 to 8 stitches per inch.

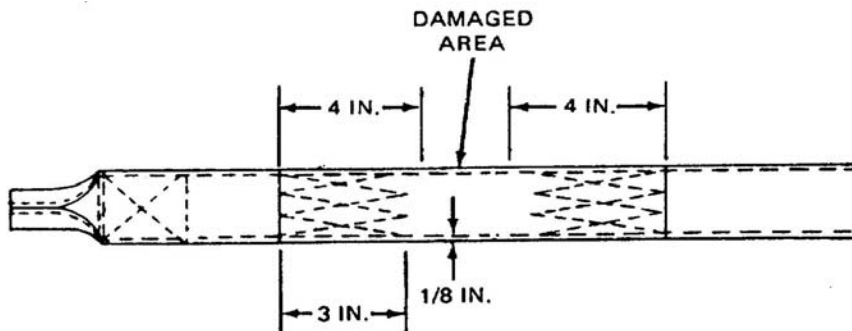

Figure 2. Riser Splicing Details.

END OF TASK

REPLACE

Replace an unserviceable individual riser strap, a spreader, or the entire riser assembly by fabricating as follows (refer to Figure 3):

NOTE

Prior to disconnecting a riser strap from the suspension lines, temporarily secure the applicable suspension line groups, to prevent disarrangement, by passing a suitable length of ¼-inch Type I cotton webbing through the loops on the lower end of the suspension lines and tying the webbing ends together.

1. Left Riser Strap.

- a. Disconnect the riser strap from the suspension lines by cutting the two suspension line attaching loops at the strap top. Ensure the suspension lines are not damaged during the cutting process. Also, ensure the two groups of suspension lines are separated.
- b. Cut and remove the stitching which secures the spreader webbing around the riser strap and remove the strap from between the spreader webbing plies. Also, remove the parachute inspection data record (log record) from the record pocket on the riser strap and retain the record for further use, if serviceable.
- c. Cut a 71 ½ -inch length of 1 23/32-inch wide, Type VIII nylon webbing, and sear the ends.
- d. Using a suitable marking aid, mark the webbing length at points 6 inches from one end and 5 ½ inches from the opposite end.
- e. On each side of the 6 and 5 ½-inch marks, roll 2 inches of the webbing edges into the center of the webbing width (Figure 3). Secure each rolled edge by stitching a 4-inch long row of stitching ⅛ inch from edges. Also, make a row of stitching laterally across the webbing width at each end of the rolled edges. Stitching will be 5 to 8 stitches per inch using size 3 nylon thread and a heavy-duty sewing machine.

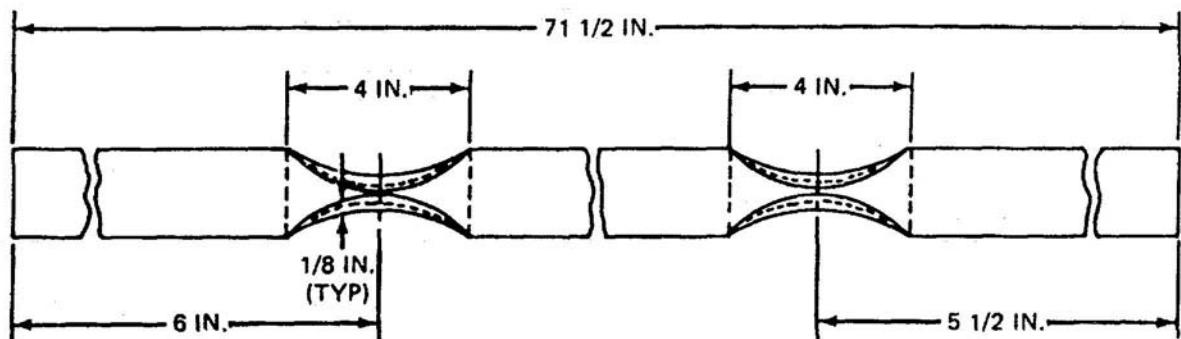

Figure 3. Riser Suspension Line Attaching Loops Construction Details.

- f. Tape each of the 4-inch long rolled edge areas with five spiral turns of 1-inch wide pressure sensitive tape (Figure 1).
- g. Invert the webbing length with the rolled edges facing down. Using a suitable marking aid, mark the webbing at points 31 inches from each end.
- h. Cut a 9 ½-inch length of 1 ¾-inch wide, Type VIII cotton webbing, for use as a buffer and wax the ends.
- i. Place the webbing length between the two marks made in (g), above, and secure the webbing to the riser strap by stitching a 9 ½-inch long four point WW stitch formation, 1/8 inch from each webbing side edge, using the details in Figure 2. Stitching will be 5 to 8 stitches per inch using size 3 nylon thread and a heavy-duty sewing machine.
- j. Form the riser strap suspension attaching loops by passing each end of the riser strap through the end loops of the original suspension line groups according to original attachment details (WP 0036, Figure 4) and center each of the strap-taped rolled edges in the applicable end loops. Then fold the strap ends as shown in Figure 2, allowing a ½-inch overlap on one end.
- k. Beginning at a point 2 inches below the tops of the formed strap suspension line attaching loops, secure the riser strap plies together by stitching with a heavy-duty sewing machine, using size 3 nylon thread, 5 to 8 stitches per inch, following the details in Figure 2. Ensure the parachute inspection data pocket (log record pocket) is formed between the strap plies by omitting 3 ½ inches of stitching down along the strap outer edge, beginning at a point 11 inches above the lower end of the strap clevis attaching loop.
- l. Pass the strap running end down between the spreader webbing plies to a point 2 inches below the strap top. Secure the spreader webbing plies to the strap by stitching with a heavy-duty sewing machine, using size 3 nylon thread, 5 to 8 stitches per inch, following the details in Figure 2. Remove the temporary tie made on the lower end loops of the suspension line group.
- m. Stencil the parachute inspection data pocket (log record pocket) identification markings on the riser straps according to original stenciling details, using the procedures in WP 0014. Reinstall the parachute inspection data record (log record), if serviceable, in the log record pocket in accordance with WP 0003.

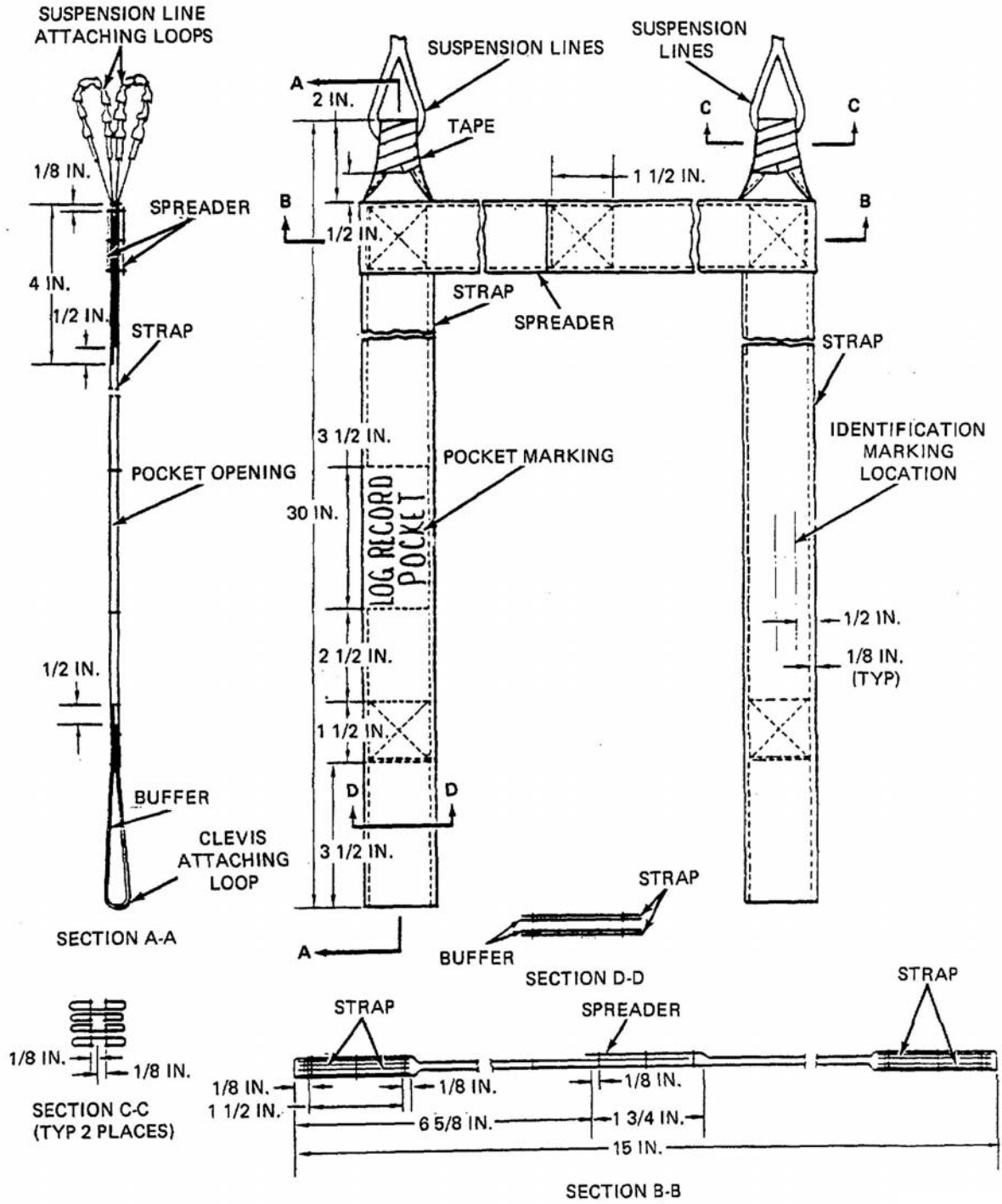

Figure 4. Riser Assembly Construction Details.

2. Right Riser Strap. Replace a right riser strap using the procedures in paragraph (1) above. However, details for forming the parachute inspection data pocket (log record pocket) do not apply to the right riser strap. In addition, only the riser identification markings will be stenciled on the right riser strap. The stenciling will be performed according to original stenciling details, using the procedures in WP 0014.
3. Spreader.
 - a. Cut and remove the stitching which secures the spreader webbing around each of the riser straps. Remove the spreader from the riser assembly by cutting the spreader webbing.
 - b. Cut 31 $\frac{3}{4}$ -inch length of 1 $\frac{23}{32}$ -inch wide, Type VIII nylon webbing, and sear the ends.
 - c. Fold the webbing length around each end of the riser straps according to original construction details and make a 1 $\frac{3}{4}$ -inch overlap of the webbing ends at the center between the two riser straps. Secure the spreader webbing plies together and also attach the webbing in the original location on each riser strap by stitching according to the details in Figure 4. Using the same details, secure the overlapped spreader webbing ends by stitching a 1 $\frac{1}{2}$ -inch wide single box-X stitch formation. Stitching will be made with a heavy-duty sewing machine, using size 3 nylon thread, 5 to 8 stitches per inch.

END OF TASK

END OF WORK PACKAGE

**SERVICE MAINTENANCE
26-FOOT DIAMETER, HIGH-VELOCITY CARGO PARACHUTE ASSEMBLY
DEPLOYMENT BAG
REPAIR, REPLACE**

INITIAL SETUP:**Equipment Condition**

Inspected (WP 0006)
Cleaned (WP 0007)
Detached from canopy and static line.

Personnel Required

92R1P Parachute Rigger

REPAIR

Refer to individual repair procedures in work packages to follow.

CAUTION

When performing a repair on a deployment bag, that requires cutting or stitching on an original part, ensure that adjacent bag material is not damaged during the cutting process.

END OF TASK**REPLACE**

An unrepairable deployment bag will be replaced with a serviceable bag from stock.

END OF TASK**END OF WORK PACKAGE**

SERVICE MAINTENANCE
26-FOOT DIAMETER, HIGH-VELOCITY CARGO PARACHUTE ASSEMBLY
DEPLOYMENT BAG ATTACHING LOOP
REPAIR, REPLACE

INITIAL SETUP:**Tools**

Knife (WP 0049, Item 5)
 Sewing Machine, Light-Duty (WP 0049, Item 14)
 Sewing Machine, Heavy-Duty (WP 0049, Item 17)
 Pot, Melting, Electric (WP 0049, Item 12)
 Yardstick (WP 0049, Item 22)
 Shears (WP 0049, Item 13)

Personnel Required

92R1P Parachute Rigger

Materials/Parts

Beeswax, Technical, 1 LB (WP 0050, Item 2)
 Thread, Nylon, Size E (WP 0050, Items 33/34)
 Thread, Nylon, Size 3 (WP 0050, Items 36/37)
 Thread, Nylon, Size FF, Type I (WP 0044, Item 7)
 Webbing, Cotton, Type II (WP 0050, Item 42)
 Wax, Paraffin, Technical (WP 0050, Item 40)
 Webbing, Nylon, Type VIII (WP 0050, Item 44)
 Webbing, Nylon, Type IV (WP 0044, Item 14)

Equipment Condition

Inspected (WP 0006)
 Cleaned (WP 0008)
 Shaken (WP 0007)
 Laid out on work table.

References

WP 0013
 WP 0014
 MAM-ATCOM 96-15

REPAIR

1. Stitch and restitch with nylon thread, size E, which matches the color of the original stitching, when possible. Lock all straight stitching by backstitching at least $\frac{1}{2}$ inch. Restitch by overstitching each end of the stitch formation by $\frac{1}{2}$ inch. Restitch directly over the original stitching. Follow the original stitch pattern as closely as possible.
2. Mark and restencil in accordance with WP 0014.

END OF TASK**REPLACE**

Replace a damaged attaching loop by fabricating as follows:

1. Remove original attaching loop from bag inside by cutting and removing stitching securing loop.
2. Cut a 16-inch length of 1-inch wide cotton webbing and wax ends (WP 0013).
3. Fold webbing length according to original construction details in Figure 1.
4. Place folded webbing in original attaching loop location and secure webbing loop by stitching a $2 \frac{7}{8}$ -inch long three-point WW stitch formation according to details in Figure 1. Stitching will be made with a light-duty sewing machine using size E nylon thread, 7 to 11 stitches per inch.

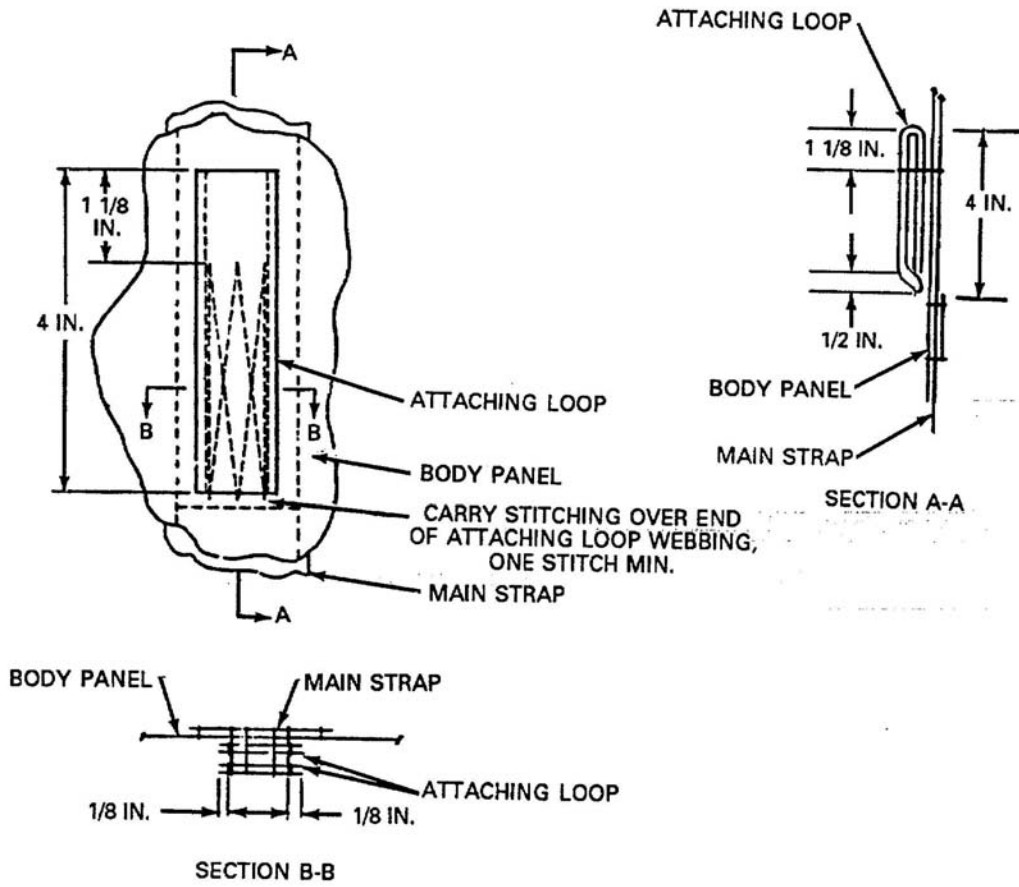

Figure 1. Attaching Loop Fabrication Details.

END OF TASK

Replace a deployment bag attaching loop (Cotton D-BAG only, IAW MAM-ATCOM 96-15)

If the parachute assembly is used in a breakaway configuration "Cotton Deployment bag ONLY," follow procedures to complete the Minor Alteration IAW MAM-ATCOM 96-15.

1. Remove the existing cotton loop from the deployment bag and discard.
2. Cut a piece of Nylon, Type VIII webbing 6 ½ inches long and underfold each end of the webbing ½ inch.
3. Position one end of the webbing 13 inches from the mouth of the deployment bag and sew it to the inside of the bag, over the bottom main strap. This webbing must be sewn with FF nylon thread, 7 to 11 stitches per inch, ⅛ inch from the edge of the webbing, in a box formation.
4. Cut a piece of Nylon, Type IV, 1-inch webbing, 8 ¼-inches long, turning it under 1 inch on one end and 3 inches on the other end. The ends of the webbing should touch to make a loop of webbing with an overall length of 4 inches.
5. Center this loop on the Type VIII webbing, locating the loop end with the 3-inch turnunder at 13 ½ inches from the mouth of the deployment bag.
6. Secure the folded loop with a three-point WW stitch formation that will form a 1 1/8-inch loop toward the mouth of the deployment bag. Stitching will be accomplished with a size 3 nylon thread, 5 to 8 stitches per inch. Overstitch by one stitch at the webbing end.

END OF TASK

END OF WORK PACKAGE

SERVICE MAINTENANCE
26-FOOT DIAMETER, HIGH-VELOCITY CARGO PARACHUTE ASSEMBLY
DEPLOYMENT BAG MAIN STRAP (SIDE AND CENTER)
REPAIR, REPLACE

INITIAL SETUP:**Tools**

Knife (WP 0049, Item 5)
 Sewing Machine, Light-Duty (WP 0049, Item 14)
 Yardstick (WP 0049, Item 22)
 Shears (WP 0049, Item 13)

Personnel Required

92R1P Parachute Rigger

Materials/Parts

Beeswax, Technical, 1 LB (WP 0050, Item 2)
 Thread, Nylon, Size E (WP 0050, Items 33/34)
 Webbing, Cotton, Type VIII, 1 3/4 IN (WP 0050, Item 43)
 Wax, Paraffin, Technical (WP 0050, Item 40)
 Pencil, Marking Aid (WP 0050, Items 21/22)

Equipment Condition

Inspected (WP 0006)
 Cleaned (WP 0008)
 Shaken (WP 0007)
 Laid out on work table.

References

WP 0012
 WP 0013

REPAIR

Repair a side or center main strap as follows:

1. **Stitching.** Stitch and restitch with nylon thread, size E, which matches the color of the original stitching when possible. Lock all straight stitching by backstitching at least 1/2 inch. Restitch by overstitching each end of the stitch formation by 1/2 inch. Restitch directly over the original stitching. Follow the original stitch pattern as closely as possible (WP 0012).
2. **Splicing.** A deployment bag side or center main strap may be spliced an unlimited number of times as follows:
 - a. As applicable, according to location of damaged area, cut and remove original stitching that secures tie loop on bag outside, attaching loop on bag inside, or 1 inch of stitching on each side of the center main strap, which secures suspension line protector flap.
 - b. Cut a length of 1 3/4-inch wide, Type VIII cotton webbing long enough to extend 4 inches beyond each side of damaged area. Wax ends in accordance with WP 0013.
 - c. Center webbing length over damaged area (Figure 1) and secure each end of splice webbing by stitching a 2-inch long, single Box X stitch formation with one double end. Stitching will be made with a light-duty sewing machine using size E nylon thread, 7 to 11 stitches per inch.
 - d. As applicable, reinstall items removed in (a), above, by restitching according to original construction details in WP 0012.

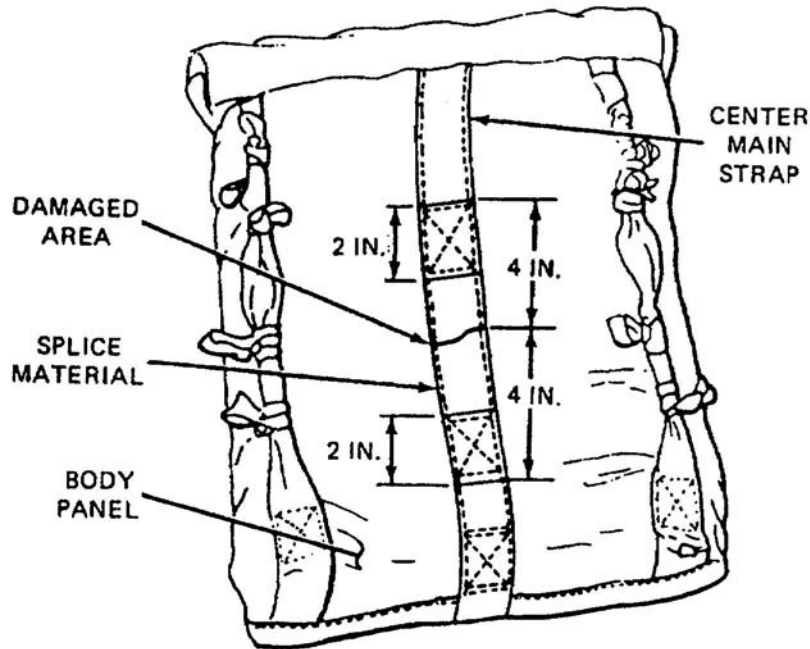

Figure 1. Main Strap Splicing Details.

END OF TASK

REPLACE

Replace a side or center main strap that is damaged beyond repair by fabricating as follows:

1. Center Main Strap.

- a. Remove the attaching loop from the bag inside by cutting the stitching which secures the attaching loop to the center main strap.
- b. Remove the suspension line protector flap by cutting the stitching which secures the flap to the bag body.
- c. Cut the stitching which secures the bag upper end reinforcement over the center main strap at two points for a distance of 3 inches on each side of the strap.
- d. Remove the original center main strap by cutting the stitching which secures the strap to the bag main panel.
- e. Cut a 53-inch length of 1 $\frac{3}{4}$ -inch wide, Type VIII cotton webbing and wax the ends.

- f. Using a suitable marking aid, mark the webbing lengths at the center. On each side of the center mark, roll 2 ¼ inches of the webbing edges to the center of the webbing width (Figure 2). Secure the rolled edges by making three rows of stitching laterally across the center of the rolled webbing. Stitching will be made with a light-duty sewing machine using size E nylon thread, 7 to 11 stitches per inch.

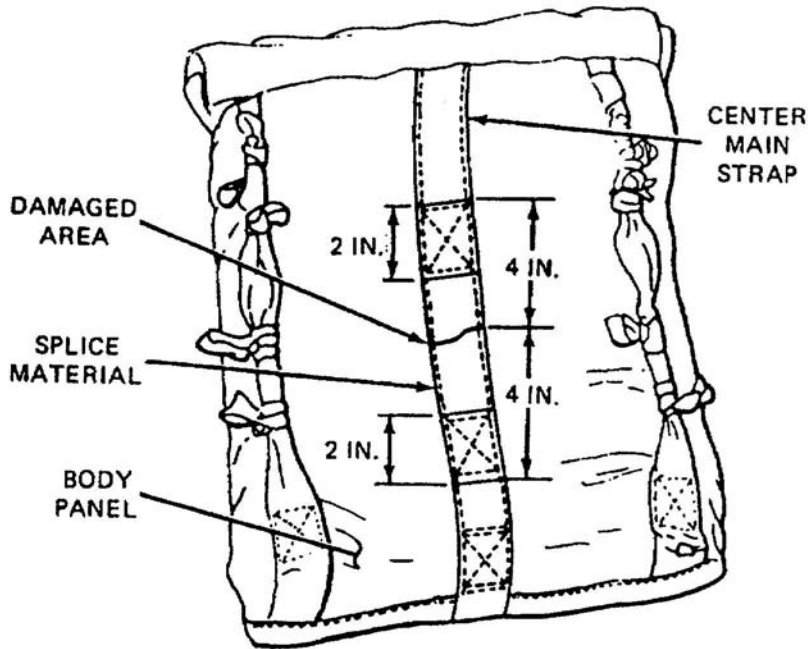

Figure 2. Main Strap Construction Details.

- g. Position webbing strap in the original center main strap location, with the rolled edges at the bag upper end, and make a 3 ¼-inch long turnunder on each webbing end. Secure the strap to the bag body by stitching according to original construction details and the details in Figure 3. Stitching will be made with a light-duty sewing machine using size E nylon thread, 7 to 11 stitches per inch. When positioning a replacement center main strap, ensure the strap rolled edges are located under the side main strap rolled edges at the bag upper end.
- h. Reposition the loose sides of the bag upper end reinforcement removed in (c), above, and restitch according to original construction details with a light-duty sewing machine using size E nylon thread, 7 to 11 stitches per inch.
- i. Position the suspension line protector flap removed in (b), above, in the original location and secure the flap by stitching according to original construction details. Stitching will be made with a light-duty sewing machine using size E nylon thread, 7 to 11 stitches per inch.
- j. Position the attaching loop removed in (b), above, in the original location and secure the loop by stitching according to original construction details. Stitching will be made with a light-duty sewing machine, using size E nylon thread, 7 to 11 stitches per inch.

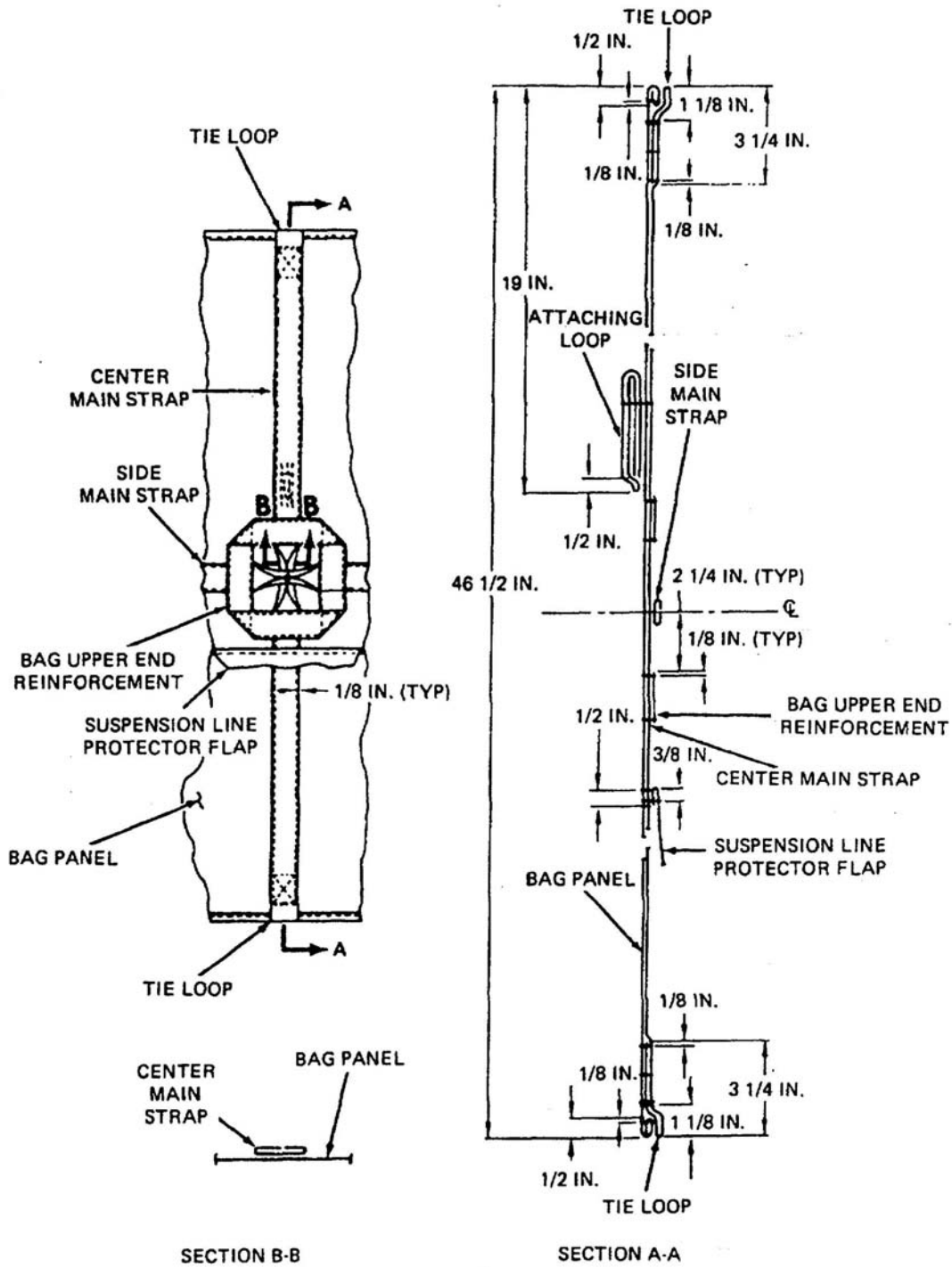

Figure 3. Center Main Strap Installation Details.

2. Side Main Strap.

- a. Remove each of the static line retaining straps and tie loops from the bag side main strap by cutting the stitching securing each loop.
- b. Cut the stitching which secures the bag upper end reinforcement over the side main strap at two points for a distance of 3 inches on each side of the strap.
- c. Cut a suitable amount of stitching which secures the folded lower edge of each side gusset panel over each of the side main strap ends.
- d. Remove the original side main strap by cutting the stitching which secures the strap to the bag main panel and side gusset panels.
- e. Cut a 72 inch length of 1¾-inch wide, Type VIII cotton webbing and wax the ends.
- f. Using a suitable marking aid, mark the webbing length at the center. On each side of the center mark, roll 2 ¼ inches of the webbing edges to the center of the webbing width. Secure the rolled edges by making three rows of stitching laterally across the center of the rolled webbing, according to original construction details. Stitching will be made with a light-duty sewing machine using size E nylon thread, 7 to 11 stitches per inch.
- g. Position the webbing strap in the original side main strap location with the rolled edges located at the bag upper end, on top of the center main strap rolled edges. Secure the strap to the side gusset panels and the bag main panel by stitching according to original construction details and the details in Figure 4. Stitching will be made with a light-duty sewing machine using size E nylon thread, 7 to 11 stitches per inch.
- h. Refold the lower edge of each side gusset panel and restitch according to original construction details with a light-duty sewing machine using size E nylon thread, 7 to 11 stitches per inch.
- i. Reposition the loose sides of the bag upper end reinforcement removed in (c), above, in the original location and restitch according to original construction details with a light-duty sewing machine using size E nylon thread, 7 to 11 stitches per inch.
- j. Position each of the static line retaining straps and tie loops removed in (a), above, in the original location and secure each item by stitching according to original construction details. Stitching will be made with a light-duty sewing machine using size E nylon thread, 7 to 11 stitches per inch.

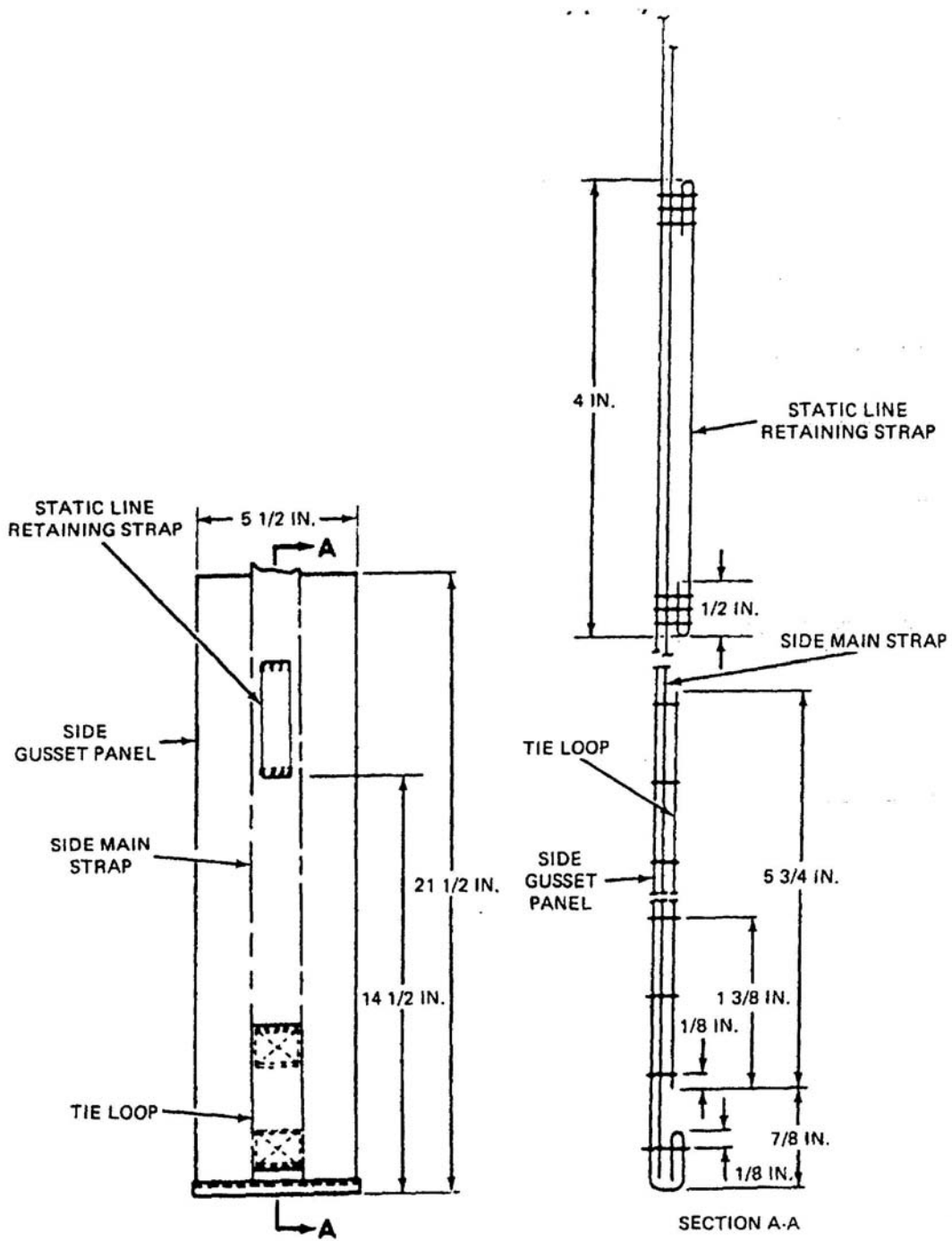

Figure 4. Side Main Strap Replacement Details.

END OF TASK

END OF WORK PACKAGE

SERVICE MAINTENANCE
26-FOOT DIAMETER, HIGH-VELOCITY CARGO PARACHUTE ASSEMBLY
DEPLOYMENT BAG STATIC LINE RETAINING STRAP
REPAIR, REPLACE

INITIAL SETUP:**Personnel Required****Tools**

92R1P Parachute Rigger

Pot, Melting, Electronic (WP 0049, Item 12)
 Knife (WP 0049, Item 5)
 Sewing machine, Light-Duty (WP 0049, Item 14)
 Yardstick (WP 0049, Item 22)

Equipment Condition

Inspected (WP 0006)
 Cleaned (WP 0008)
 Shaken (WP 0007)
 Deployment bag laid out on
 work table.

Materials/Parts

Beeswax, Technical (WP 0050, Item 2)
 Thread, Nylon, Size E (WP 0050, Items 33/34)
 Webbing, Cotton, Type II, 1 IN (WP 0050, Item 42)
 Wax, Paraffin, Technical (WP 0050, Item 40)

References:

WP 0029

REPAIR

Stitch and restitch broken or loose stitching with nylon thread, size E, which matches the color of the original stitching, when possible. Lock all straight stitching by backstitching at least ½ inch. Restitch by overstitching each end of the stitch formation by ½ inch. Restitch directly over the original stitching. Follow the original stitch pattern as closely as possible.

END OF TASK**REPLACE**

Replace a damaged static line retaining strap located on the side main strap by fabricating as follows:

1. Remove the original retaining strap by cutting the stitching which secures the strap to the side main strap.
2. Cut a 5-inch length of 1-inch wide, Type II cotton webbing and wax the ends.
3. Make a ¼-inch long turnunder on each end of the webbing length and position the webbing in the original retaining strap location with the turnunders facing down. Secure the replacement strap by making three rows of stitching across each strap according to original construction details and the details in Figure 1, WP 0029. Stitching will be made with a light-duty sewing machine using size E nylon thread, 7 to 11 stitches per inch.
4. No repairs authorized on Universal Static Line (USL).

END OF TASK**END OF WORK PACKAGE**

SERVICE MAINTENANCE
26-FOOT DIAMETER, HIGH-VELOCITY CARGO PARACHUTE ASSEMBLY
DEPLOYMENT BAG SUSPENSION LINE RETAINING STRAP
REPAIR, REPLACE

INITIAL SETUP:**Tools**

Pot, Melting, Electric (WP 0049, Item 12)
 Knife (WP 0049, Item 5)
 Sewing machine, Light-Duty (WP 0049, Item 14)
 Yardstick (WP 0049, Item 22)

Personnel Required

92R1P Parachute Rigger

Equipment Condition

Inspected (WP 0006)
 Cleaned (WP 0008)
 Shaken (WP 0007)
 Deployment bag laid out on
 work table.

Materials/Parts

Beeswax, Technical, 1 LB (WP 0050, Item 2)
 Thread, Nylon, Size E (WP 0050, Items 33/34)
 Webbing, Cotton, Type II, 1 IN (WP 0050, Item 42)
 Wax, Paraffin, Technical (WP 0050, Item 40)

REPAIR

Stitch and restitch broken or loose stitching with nylon thread, size E, which matches the color of the original stitching, when possible. Lock all straight stitching by backstitching at least $\frac{1}{2}$ inch. Restitch by overstitching each end of the stitch formation by $\frac{1}{2}$ inch. Restitch directly over the original stitching. Follow the original stitch pattern as closely as possible.

END OF TASK**REPLACE**

Replace a damaged suspension line retaining strap by fabricating as follows:

1. Cut 3 inches of stitching on each end of the suspension line protector flap edge and fold the loose sides of the flap in toward the bag center.
2. Remove the original suspension line retaining strap by cutting the strap webbing flush with each side of the original single Box X stitch formations. Ensure the tie loop formed on the lower end of the strap is also removed by cutting the loop material flush with adjacent X-box stitch formation.
3. Cut a 20 $\frac{3}{4}$ -inch length of 1-inch wide, Type II cotton webbing and wax the ends.
4. Make a 2 $\frac{1}{4}$ -inch long foldunder on one end of the webbing length to form a tie loop and position the webbing in the original strap location with the foldunder facing down and aligned with the lower end of the bag panel. Using the remaining original stitch formations as reinforcement, secure the replacement strap by stitching according to original construction details and the details in Figure 1. Stitching will be made with a light-duty sewing machine using size E nylon thread, 7 to 11 stitches per inch.
5. Position the sides of the suspension line protector flap in the original location and restitch the flap upper end according to original location and original construction details, with a light-duty sewing machine using size E nylon thread, 7 to 11 stitches per inch.

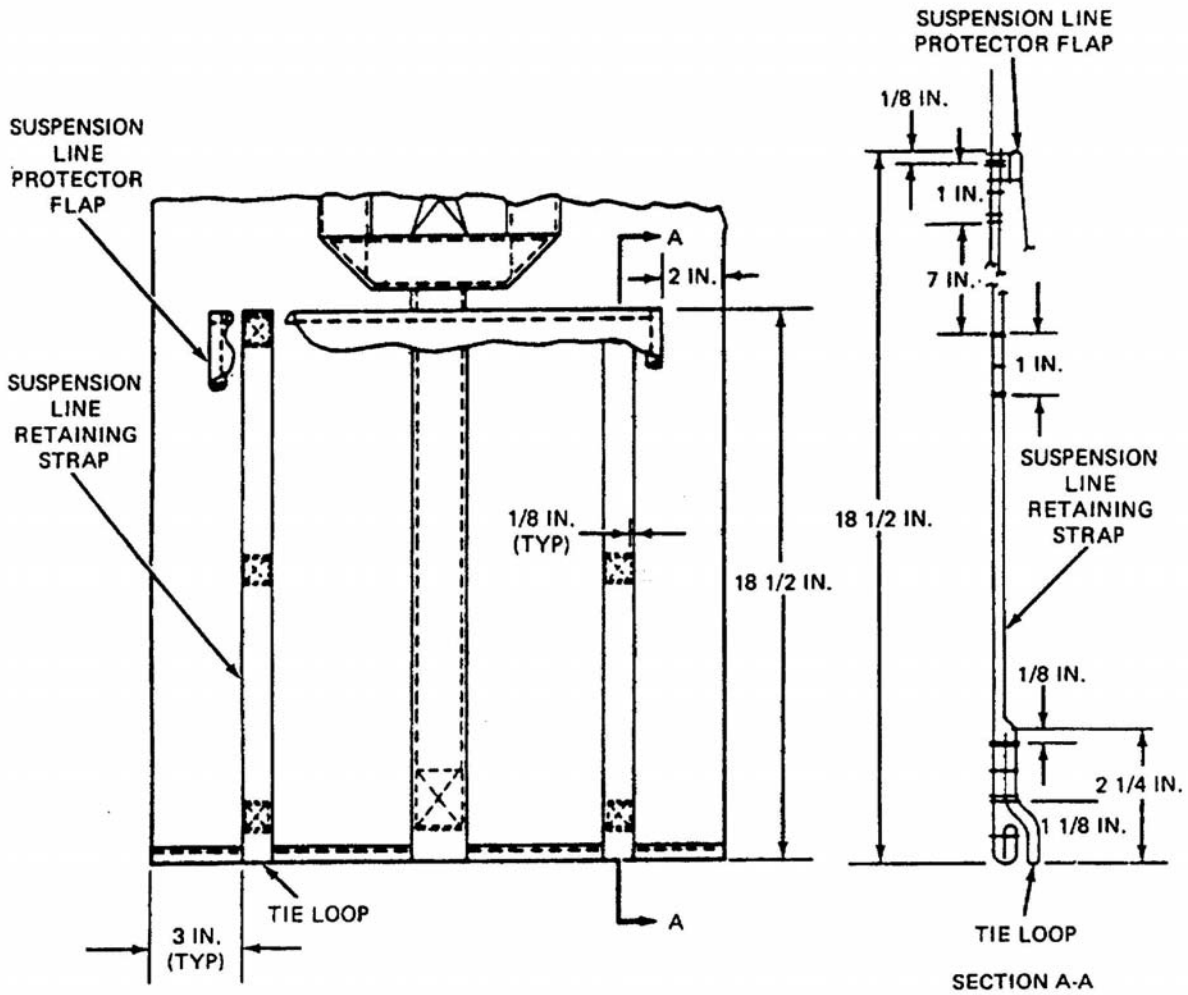

Figure 1. Suspension Line Retaining Strap Replacement Details.

END OF TASK

END OF WORK PACKAGE

SERVICE MAINTENANCE
26-FOOT DIAMETER, HIGH-VELOCITY CARGO PARACHUTE ASSEMBLY
DEPLOYMENT BAG TIE LOOPS
REPAIR, REPLACE

INITIAL SETUP:**Tools**

Knife (WP 0049, Item 5)
 Sewing machine, Light-Duty (WP 0049, Item 14)
 Yardstick (WP 0049, Item 22)

Personnel Required

92R1P Parachute Rigger

Materials/Parts

Thread, Nylon, Size E (WP 0050, Items 33/34)
 Webbing, Cotton, Type II, 1 IN (WP 0050, Item 41)
 Webbing, Cotton, Type VIII (WP 0050, Item 43)

Equipment Condition

Inspected (WP 0006)
 Cleaned (WP 0008)
 Shaken (WP 0007)
 Laid out on work table.

References

WP 0012
 WP 0027

REPAIR

Stitch and restitch broken or loose stitching according to original construction details with thread which matches the color of the original stitching, when possible. Lock all straight stitching by backstitching at least ½ inch. Restitch by overstitching each end of the stitch formation by ½ inch. Restitch directly over the original stitching. Follow the original stitch pattern as closely as possible in accordance with WP 0012.

END OF TASK**REPLACE**

1. Protector flap tie loop. Replace a damaged protector flap tie loop by fabricating as follows:
 - a. Remove the original tie loop by cutting the stitching which secures the loop to the suspension line protector flap.
 - b. Cut a 6 ½-inch length of 1-inch wide, Type II cotton webbing and fold the webbing length according to the details in Figure 1 to form a 3 ¼-inch long tie loop.
 - c. Position the formed tie loop in the original tie loop location and secure the loop by stitching according to original construction details and the details in Figure 1. Stitching will be made with a light-duty sewing machine using size E nylon thread, 7 to 11 stitches per inch.
2. Side Main Strap Tie Loop. Replace a damaged side main strap tie loop by fabricating as follows:
 - a. Remove the original tie loop by cutting the stitching which secures the loop to the side main strap and the side gusset panel.
 - b. Cut a 5 ¾-inch length of 1 ¾-inch wide, Type VIII cotton webbing and wax the ends.
 - c. Position the webbing length in the original loop location and secure the webbing by stitching

according to original construction details and the details in Figure 4, WP 0027. Stitching will be made with a light-duty sewing machine using size E nylon thread, 7 to 11 stitches per inch.

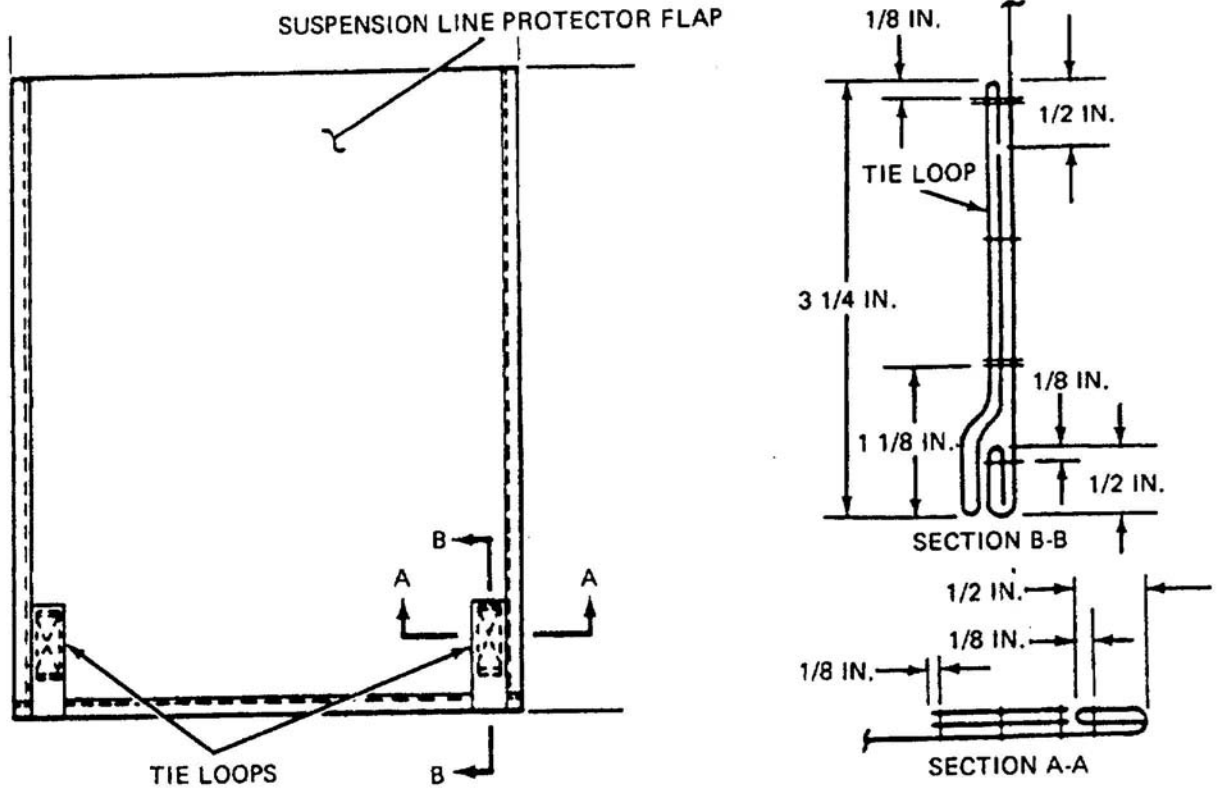

Figure 1. Protector Flap Tie Loop Replacement Details.

END OF TASK

END OF WORK PACKAGE

SERVICE MAINTENANCE
26-FOOT DIAMETER, HIGH-VELOCITY CARGO PARACHUTE ASSEMBLY
DEPLOYMENT BAG PANELS AND FLAPS
REPAIR

INITIAL SETUP:**Tools**

Shears (WP 0049, Item 13)
 Knife (WP 0049, Item 5)
 Sewing Machine, Darning (WP 0049, Item 19)
 Sewing Machine, Light-Duty (WP 0049, Item 14)
 Yardstick (WP 0049, Item 22)

Materials/Parts

Thread, Nylon, Size E (WP 0050, Items 33/34)
 Cloth, Cotton, Duck, 12.29 oz. (WP 0050, Item 8)
 Pencil, Marking Aid (WP 0050, Items 21/22)

Personnel Required

92R1P Parachute Rigger

Equipment Condition

Inspected (WP 0006)
 Cleaned (WP 0008)
 Shaken (WP 0007)
 Laid out on work table.

References

WP 0012
 WP 0014

REPAIR

1. **Stitching.** Stitch and restitch broken or loose stitching with thread that matches the color of the original stitching, when possible. Use a light-duty sewing machine and size E nylon thread, 7 to 11 stitches per inch. Lock all straight stitching by backstitching at least ½ inch. Restitch by overstitching each end of the stitch formation by ½ inch. Restitch directly over the original stitching. Follow the original stitch pattern as closely as possible in accordance with WP 0012.
2. **Darning.** Darn a hole or tear which does not exceed ¾ inch in length or diameter according to procedures in WP 0012, using a darning sewing machine with size E nylon thread, 7 to 11 stitches per inch. There is no limit to the number of darns which may be made on the bag panels and flaps.
3. **Patching.** Patch a hole or tear which exceeds ¾ inch in length or diameter using 12.29 oz. cotton duck cloth, a light-duty sewing machine, and size E nylon thread, 7 to 11 stitches per inch (see specifications table, WP 0012). There is no limit to the number of patches which may be made on the bag panels and flaps. Proceed as follows:

NOTE

Patches may be applied to the inside or outside of deployment bag.

- a. Smooth fabric around the damaged area and secure with pushpins. Do not pin damaged area.
- b. Using an authorized marking aid of contrasting color, mark a square or rectangle around the area to be patched and ensure one side of the marked square or rectangle is parallel to warp or filling of fabric.
- c. Cut damaged area of fabric along lines made in (b) above. Further cut fabric diagonally at each corner to allow ½-inch foldback in raw edges.

- d. Make a 1/2-inch foldback on each raw edge. Pin and baste each foldback to complete prepared hole. Basting will be performed using procedures in WP 0012.
 - e. Using duck cloth, mark and cut a patch 2 1/2 inches wider and longer than inside measurements of the prepared hole. Ensure that patch material is marked and cut along the warp or filling of fabric.
 - f. Center patch material over prepared hole and ensure the warp or filling of patch material matches warp or filling of fabric being patched. Pin patch material in position.
 - g. Make a 1/2-inch foldunder on each edge of patch material and baste patch to prepared area. Basting will be performed using procedures in WP 0012.
 - h. Remove pushpins securing the item to repair table and secure the patch by stitching, using applicable details in Figure 1, and stitching with a light-duty sewing machine, size E nylon thread, 7 to 11 stitches per inch. Make first row of stitching completely around patch. Turn deployment bag inside out and make a second row of stitching around prepared hole. Stitching will be performed in accordance with WP 0012.
4. Restenciling. As required, restencil identification markings on the suspension line protector flap using procedures in WP 0014.

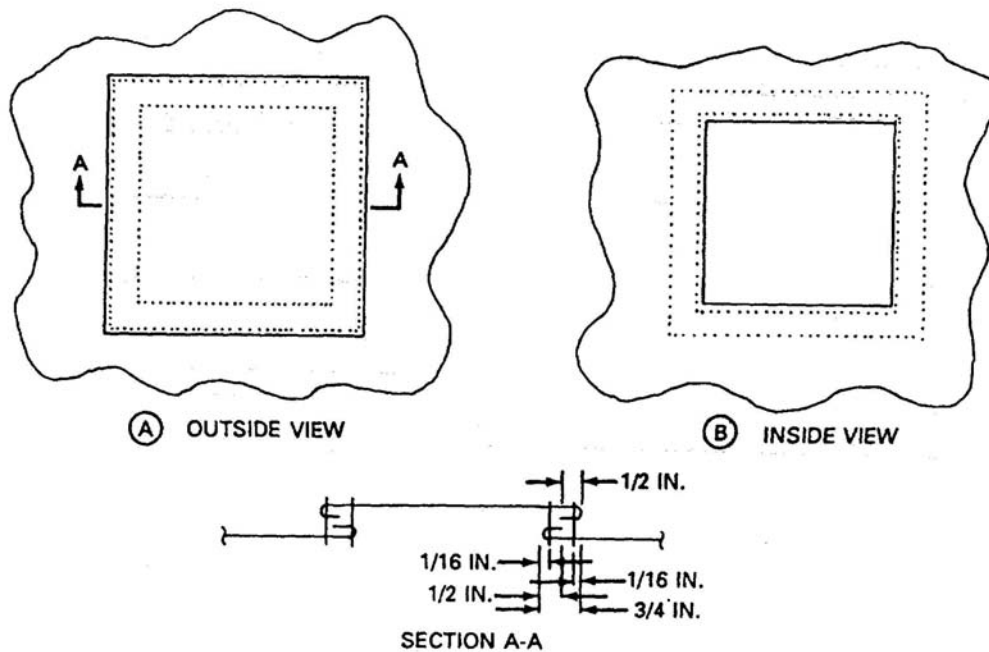

Figure 1. Patching Deployment Bag Panels and Flaps.

END OF TASK

END OF WORK PACKAGE

SERVICE MAINTENANCE
26-FOOT DIAMETER, HIGH-VELOCITY CARGO PARACHUTE ASSEMBLY
STATIC LINE
REPAIR, REPLACE

INITIAL SETUP:**Tools**

Knife (WP 0049, Item 5)
 Knife, Hot Metal (WP 0049, Item 6)
 Sewing Machine, Zig-Zag (WP 0049, Item 15)
 Yardstick (WP 0049, Item 22)
 Machine, Stencil Cutting (WP 0049, Item 8)

Personnel Required

92R1P Parachute Rigger

Equipment Condition

Inspected (WP 0006)
 Cleaned (WP 0008)
 Shaken (WP 0007)
 Laid out on work table.

Materials/Parts

Thread, Nylon, Size FF (WP 0050, Item 35)
 Pencil, Marking Aid (WP 0050, Items 21/22)
 Tape, Pressure Sensitive (WP 0050, Item 30)
 Webbing, Nylon, Tubular, ¾ IN (WP 0050, Item 46)

References

WP 0004
 WP 0014

REPAIR

1. Stitching. Stitch and restitch broken or loose stitching using zig-zag sewing machine with size FF nylon thread that matches the color of the original stitching, when possible. Restitch by overstitching each end of the stitch formation by ½ inch. Restitch directly over the original stitching. Follow the original stitch pattern as closely as possible.
2. Marking and Restenciling. As required, restencil identification marks using the procedures in WP 0014.
3. Retaping. As required, retape static line clevis attaching loop located on one end of static line length as follows:
 - a. Remove the remains of the original tape from the static line clevis attaching loop.
 - b. Using a 2 ½-inch length of 1-inch wide, pressure-sensitive tape, wrap static line clevis attaching loop with one and one-half turns (Figure 1).

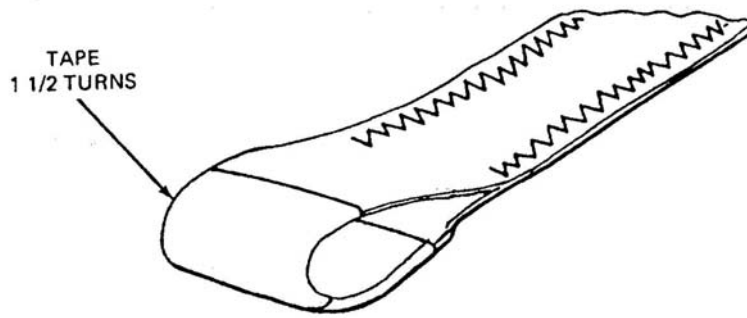

Figure 1. Retaping Static Line Clevis Attaching Loop.

END OF TASK

REPLACE

Replace an unserviceable static line by fabricating as follows:

1. Remove static line clevis from clevis attaching loop and further remove static line length from attaching loop on deployment bag. Retain static line clevis for further use, if serviceable.
2. Cut a 192- $\frac{1}{2}$ inch length of $\frac{3}{4}$ -inch wide tubular nylon webbing and sear ends.
3. Place a mark 14 inches from end and make a 7-inch long foldback on one end of the webbing length (Figure 2). Beginning at seared edge, secure foldback by stitching two $\frac{3}{16}$ -inch wide by 4-inch long rows of double-throw zig-zag stitching using size FF nylon thread, 7 to 11 stitches per inch.
4. On opposite end of webbing length, mark 11 inches from end and make a 5 $\frac{1}{2}$ -inch long foldback. Secure foldback using procedure in (3) above.
5. Using a 2 $\frac{1}{2}$ -inch length of 1-inch wide, pressure-sensitive tape, wrap the 1 $\frac{1}{2}$ -inch long loop with one and one-half turns (Figure 1).
6. Cut a 7 $\frac{1}{2}$ -inch length of $\frac{3}{4}$ -inch wide tubular nylon webbing and sear ends.
7. Place a mark 10 inches from the 3-inch loop end, opposite side of foldback.
8. Fold webbing on 4-inch mark, position seared end at 10-inch mark, and secure by stitching two $\frac{3}{16}$ -inch wide by 2 $\frac{1}{2}$ -inch long rows of double-throw zig-zag stitching, using size FF nylon thread, 7 to 11 stitches per inch.
9. Stencil part numbers 11-1-219 on static line webbing using procedures in WP 0014.
10. If required, reattach the static line to static line attaching loop on deployment bag, as outlined in WP 0011.
11. Install a serviceable riser clevis on a 1 $\frac{1}{2}$ -inch long clevis attaching loop according to original riser clevis installation details.

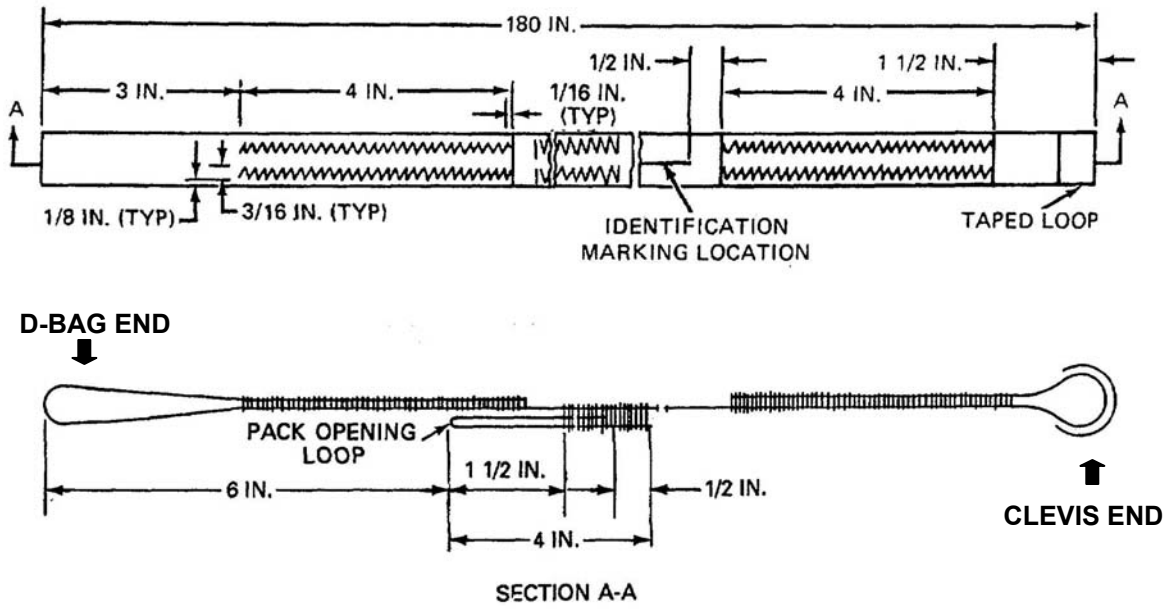

Figure 2. Static Line Construction Details.

END OF TASK

END OF WORK PACKAGE

**SERVICE MAINTENANCE
26-FOOT DIAMETER, HIGH-VELOCITY CARGO PARACHUTE ASSEMBLY
STATIC LINE CLEVIS
REPAIR, REPLACE**

INITIAL SETUP:**Tools**

Knife (WP 0049, Item 5)
Knife, Hot Metal (WP 0049, Item 6)

Personnel Required

92R1P Parachute Rigger

Materials/Parts

Cord, Nylon, Type I (WP 0050, Item 12)
Pin, Cotter (WP 0050, Item 23)
Shackle, Clevis (WP 0050, Item 25)

Equipment Condition

Inspected (WP 0006)
Cleaned (WP 0008)
Shaken (WP 0007)
Laid out on work table.

REPAIR

Repair a static line clevis using the following procedures:

1. Replacing a clevis pin retaining cord.
 - a. Cut and remove original clevis pin retaining cord from static line clevis body, clevis pin, and safety pin (Figure 1).
 - b. Cut a 16-inch length of Type I nylon cord and sear ends.
 - c. Pass one half of cord length around static line clevis body; join ends and make a square knot snug against clevis body (Figure 1).
 - d. Pass one tie running end through the eye of clevis pin and secure the tie end snug with a square knot, leaving a 3/8-inch long running end.
 - e. Make an overhand knot in the remaining running end at a point within 3/16 inch of the square knot.
 - f. Secure opposite cord running end to the eye of safety pin using procedures in (d) and (e) above.
2. Replacing a clevis safety pin.
 - a. Remove original safety pin from clevis assembly by untying overhand knot and square knot which secure pin to clevis.
 - b. Replace cotter pin from stock.
 - c. Reinstall safety pin in clevis pin.
 - d. Pass tie running end through eye of safety pin. Make an overhand knot in running end (Figure 1).
 - e. Secure tie end against safety pin with a square knot, leaving a 3/8-inch running end.

END OF TASK

REPLACE

Replace an unserviceable or missing static line clevis with a serviceable item from stock.

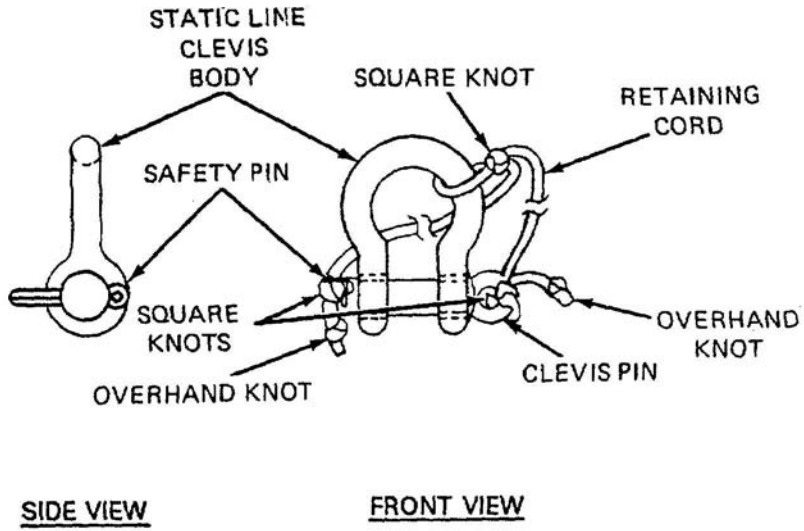

Figure 1. Replacing Clevis Pin Retaining Cord.

END OF TASK

END OF WORK PACKAGE

SERVICE MAINTENANCE
26-FOOT DIAMETER, HIGH-VELOCITY CARGO PARACHUTE ASSEMBLY
GORE SECTION
REPAIR, REPLACE

INITIAL SETUP:**Tools**

Shears (WP 0049, Item 13)
 Iron, Household (WP 0049, Item 4)
 Sewing Machine, Light-Duty (WP 0049, Item 14)
 Sewing Machine, Zig-Zag (WP 0049, Item 15)
 Yardstick (WP 0049, Item 22)

Personnel Required

92R1P Parachute Rigger

Equipment Condition

Inspected (WP 0006)
 Cleaned (WP 0008)
 Shaken (WP 0007)
 Parachute laid out on table.

Materials/Parts

Pencil, Marking Aid (WP 0050, Items 21/22)
 Cloth, Cotton, Duck (WP 0050, Item 8)
 Cloth, Cotton Balloon, Coated (WP 0050, Item 7)
 Thread, Nylon, Size E (WP 0050, Items 33/34)
 Thread, Nylon, Size A (WP 0050, Item 32)
 Cloth, Muslin, Type II (WP 0050, Item 10)

References

WP 0012
 WP 0014
 WP 0049

NOTE

Repair and/or replacement of a gore section is accomplished at the Intermediate (Field) Maintenance Level only, in accordance with the Maintenance Allocation Chart (MAC), WP 0049.

REPAIR

1. Restitching. Stitching and restitching made on parachute canopies should be accomplished with size E or A nylon thread that is contrasting in color to the fabric being stitched or the original thread being restitched. If contrasting color thread is not available, thread of matching color may be used, providing all other specifications are met. Straight stitching and restitching should be locked by at least two inches at each end of a stitch row, when possible. Zig-zag restitching should extend at least $\frac{1}{4}$ inch into undamaged stitching at each end, when possible. Restitch directly over the original stitching and follow the original stitch pattern as closely as possible.
2. Darning. Darn a hole or tear in a gore section which does not exceed $\frac{3}{4}$ inch in length or diameter as prescribed in WP 0012, using size E or A nylon thread. There is no limit to the number of darns which may be made on a gore section.
3. Patching. Use a patch to repair holes which exceed $\frac{3}{4}$ inch in length or diameter, using either the sewn patch or the pressure-sensitive patch methods.

NOTE

The following limitations apply to the 26-foot cargo parachute. The limitations prescribed for parachute canopy patching will be stringently adhered to under all circumstances and without any deviations:

A patch will not be applied to a damaged area that has been previously patched.

There is no limitation to the number of patches or size of patch to each canopy gore section or gore panel. However, determination should be made as to the most economical method to be used, i.e., two or more patches versus one large patch or one large patch versus a section replacement. A patch applied to a parachute canopy may extend from radial seam to radial seam.

4. Sewn Patches. There are two types of sewn patches authorized, the basic and miscellaneous. A basic patch is used to repair damaged cloth when the affected area is no closer than 1 inch from a radial tape, vent reinforcement tape or skirt reinforcement tape. Should a damaged area be closer than 1 inch to the cited areas, a miscellaneous patch will be made.

NOTE

Sewn patches on the canopy will be applied to the inside and may be square or rectangular in shape.

When a miscellaneous canopy patch is used, cut stitching and remove or lay aside items which may interfere with patch application. Refer to applicable item repair paragraph for proper procedures.

- a. Using an authorized marking aid of contrasting color, mark a square or rectangle around area to be patched and ensure one side of marked square or rectangle is parallel to warp or fill of fabric.
- b. Cut damaged area of fabric along lines made in paragraph 1 above. Further, cut fabric diagonally at each corner to allow a ½-inch foldback in raw edges. Cut stitching and lay aside or remove any item which will interfere with miscellaneous patch application.
- c. Make ½-inch foldback on each raw edge. Pin and baste each foldback to complete prepared hole. Basting will be performed using procedures in WP 0012.
- d. Using 3.5-ounce muslin cloth, mark and cut a patch 2½ inches wider and longer than inside measurements of prepared hole. Ensure patch material is marked and cut along warp or fill of fabric.
- e. Center patch material over prepared hole and ensure warp or fill of patch material matches warp or fill of fabric being patched. Pin patch material in position.
- f. Make ½-inch foldunder on each edge of patch material and baste patch to prepared area. Basting will be performed using procedures in WP 0012.
- g. Remove pincushions securing item to the repair table and secure patch by stitching, using the applicable details in Figure 1, and stitching specifications outlined in Table 3, WP 0012. Make first row of stitching completely around patch; invert canopy and make a second row of stitching around prepared hole. Stitching will be performed in accordance with WP 0012.
- h. Replace items removed for miscellaneous patch, as required, in accordance with applicable item procedures.

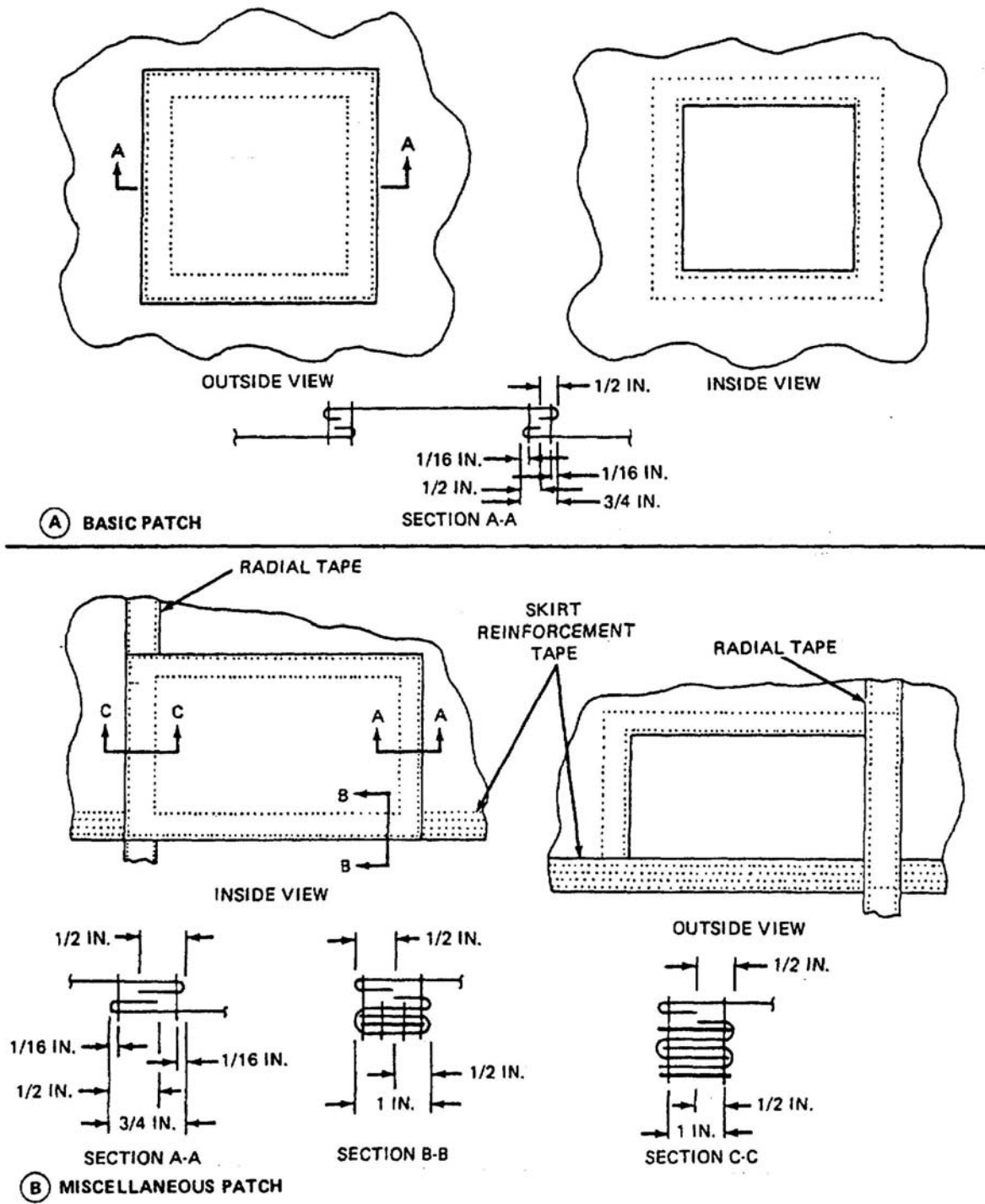

Figure 1. Patch Application Stitch Method.

5. Pressure-sensitive (iron-on) patch. This method of applying a basic patch is a heat and pressure (iron-on) technique using pressure-sensitive coated cotton balloon cloth. This method is limited to use on the cotton muslin canopies, such as the 26-foot cargo parachute. A complete canopy section replacement will be performed when an individual section has been patched extensively with the pressure-sensitive patch material and an apparent stiffening of the section occurs. The stiffening effect may adversely affect the proper layout and packing of a parachute canopy. Apply a pressure-sensitive (iron-on) patch as follows:
 - a. Smooth all wrinkles from materials surrounding the damaged area.
 - b. Cut a piece of pressure-sensitive coated cotton balloon cloth large enough to extend 1 inch beyond all edges of the damaged area. If damaged area extends to a point within 1 inch of upper lateral band, only a sewn patch, as outlined in Figure 1, B, will be allowed.
 - c. Place coated cloth patch over damaged area with adhesive side facing down. If damaged area has no material missing, patch will be applied to the inside of canopy only. Whenever damaged area has a space between the edges of material which indicates that material is missing, patch will be applied to both inside and outside of canopy (Figure 2).
 - d. Using a household-type electric iron with heat regulated for cotton material, apply heat and pressure simultaneously to patch material for at least 30 seconds. Ensure that all of patch material is subjected to heat and pressure and that all edges of patch have adhered to canopy material. Also, ensure that temperature of iron remains constant during patch application effort and that no other part of canopy is underneath area being patched.
6. Restenciling. As required, restencil identification markings using procedures in WP 0014.

END OF TASK

REPLACE

NOTE

When replacing gore sections, use 3.5 ounce cotton muslin cloth of same color as that being replaced. If the same color cloth is not available, another color may be used. When replacing section 1 of gore 1, restencil gore number and information data block on replacement section. For other gores, stencil gore numbers as necessary using procedures in WP 0014. A gore section which is damaged beyond repair will be replaced as follows:

1. Gore section 1.
 - a. Cut a piece of 3.5-ounce cotton muslin cloth 2 ½ inches longer and 1 ½ inches wider than original gore section (Figure 3).
 - b. Place cut material over damaged area and using a suitable marking device, trace outline of original gore section, including width of radial tapes on each side of damaged area and width of skirt reinforcement tape (lower lateral band) at bottom. Allow material to extend 1 inch beyond original gore section upper edge, 1½ inches below lower skirt reinforcement tape, and ¾ inch beyond outside edge of each of the radial tapes. Trim excess material, as required.
 - c. On upper end of cut material, make a double ½-inch wide foldunder. Secure foldunder with a single row of stitching sewn through foldunder center across width of material. Stitching will be 7 to 11 stitches per inch.

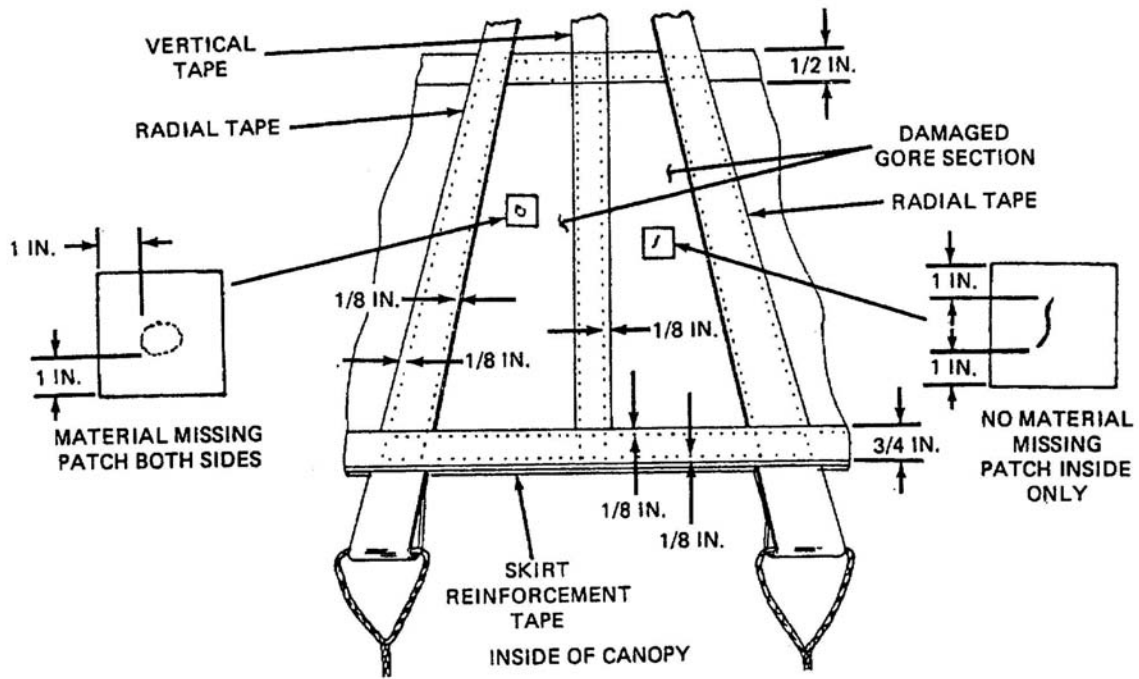

Figure 2. Pressure Sensitive Patch.

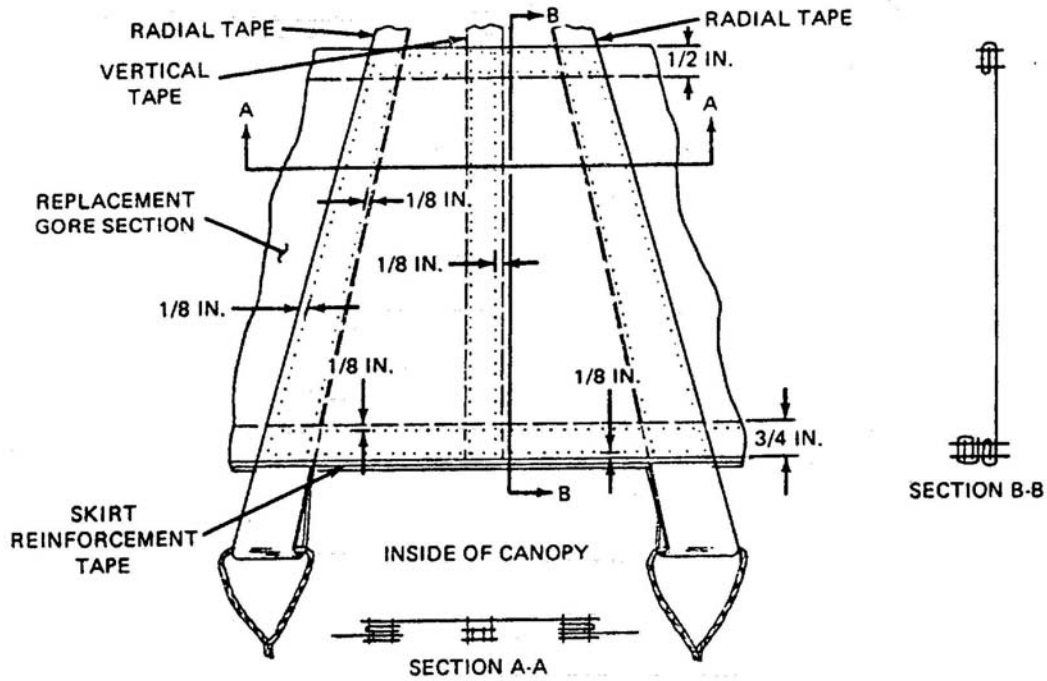

Figure 3. Gore Section 1, Replacement Details.

- d. Cut and remove original stitching which secures pocket band ends to skirt reinforcement tape (lower lateral band) in original gore section area. Fold pocket band loose ends away from repair area.
- e. Invert canopy to inside and align upper edge of foldunder made in (d), above, with upper edge of original gore section. Allow each side of replacement gore section material to extend $\frac{3}{4}$ inch beyond outside edges of original gore section radial tapes. Ensure $\frac{1}{2}$ -inch wide foldunder faces down. Temporarily secure replacement gore section to original gore section upper edge with pincushions.
- f. On each side of replacement gore section, make a $\frac{3}{4}$ -inch wide foldunder and align material folded edge with outside edge of each original gore section radial tapes. Temporarily secure foldunders with pincushions.
- g. At lower end of replacement gore section, make a doubled $\frac{3}{4}$ -inch wide foldunder and align lower edge of fold with lower edge of skirt reinforcement tape (lower lateral band). Temporarily secure foldunder with pushpins.
- h. Baste edges of replacement gore section in accordance with WP 0012 and remove pushpins.
- i. Using a light-duty sewing machine and size E thread, secure replacement gore section to original gore section radial tapes, vertical tape, and skirt reinforcement tape (lower lateral band) with two rows of stitching, using 7 to 11 stitches per inch. Ensure lower edge of replacement gore section does not extend beyond bottom of skirt reinforcement tape (lower lateral band).
- j. Remove basting, reinvert canopy to outside, and remove original gore section material by cutting down inside of each applicable radial tape, down both sides of vertical tape, and across upper edge of skirt reinforcement tape (lower lateral band).
- k. Using a zig-zag sewing machine and size E nylon thread, reinstall pocket band loose end in original location with a 2-inch long, $\frac{1}{4}$ -inch wide row of stitching (Figure 4). Stitching will be 7 to 11 stitches per inch.

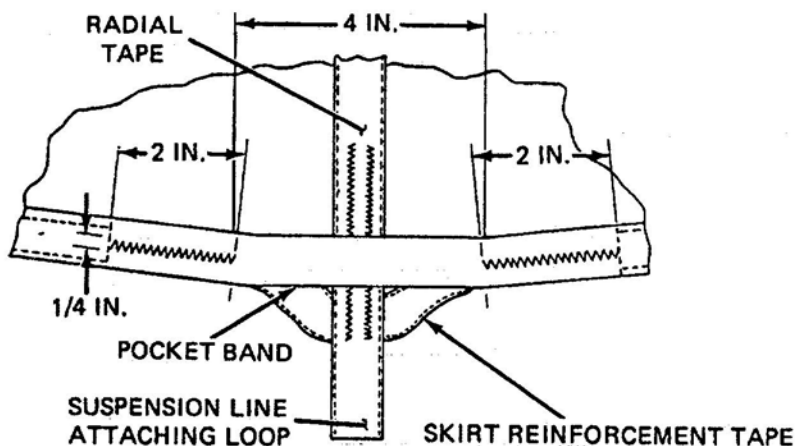

Figure 4. Reinstalling Pocket Band.

END OF TASK

2. Gore Section 2.

- a. Place canopy on a repair table with damaged gore section facing up.
- b. Cut a piece of 3.5-ounce muslin cloth 2 inches longer and 1½ inches wider than damaged gore section (Figure 5).
- c. Place cut material over damaged area and using a suitable marking device, trace outline of original gore section, including width of radial tapes on each side of damaged area. Allow material to extend 1 inch beyond top and bottom of original gore section and ¾ inch beyond outer edge of each radial tape. Trim excess material, as required.
- d. On upper and lower edges of the replacement material, make a doubled ½-inch wide fold-under. Secure each foldunder with a single row of stitching sewn through the center of fold-under, across width of material. Stitching will be 7 to 11 stitches per inch, using size E thread.
- e. Invert canopy to inside. Position replacement gore section material over the damaged area with upper and lower edges of material aligned with respective edges of original gore section. Ensure foldunders face down and that sides of material extend ¾ inch beyond outside edge of each radial tape.
- f. On each side of replacement gore section material, make a ¾-inch wide foldunder and align the folded edge with the outside edge of the damaged area radial tape. Temporarily secure foldunders with pushpins.
- g. Baste edges of replacement gore section in accordance with WP 0012 and remove pushpins.
- h. Using a light-duty sewing machine and size E thread, secure replacement gore section to original gore section radial tapes and vertical tape with two rows of stitching, using 7 to 11 stitches per inch.
- i. Remove basting, reinvert canopy to outside, and remove original gore section material by cutting down inside of each of the original gore section radial tapes and on either side of vertical tape from upper edge through lower edge of section.

END OF TASK

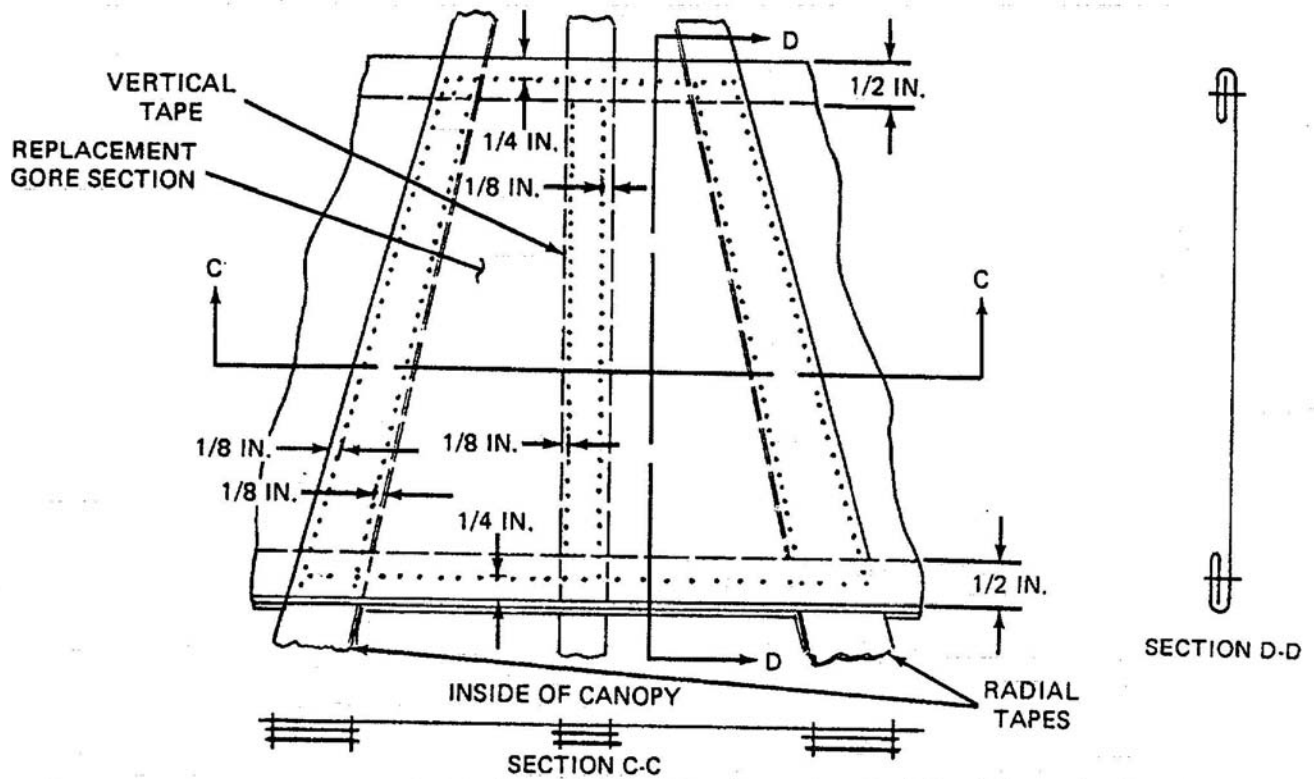

Figure 5. Gore Section 2, Replacement Details.

3. Gore Section 3.

- a. Place canopy on a repair table with damaged gore section facing up.
- b. Cut a piece of 3.5-ounce cotton cloth 2½ inches longer and 1½ inches wider than damaged gore section (Figure 6).
- c. Place cut material over damaged area and, using a suitable marking device, trace outline of original gore section, including width of radial tapes on each side of damaged area and width of skirt reinforcement tape (lower lateral band) at bottom. Allow material to extend 1 inch beyond original gore section upper edge, 1½ inches below skirt reinforcement tape (lower lateral band), and ¾ inch beyond outside edge of each radial tape. Trim excess material, as required.
- d. On lower end of cut material, make a double ½-inch wide foldunder. Secure foldunder with a single row of stitching sewn through foldunder center across width of material. Stitching will be 7 to 11 stitches per inch, using size E nylon thread and a light-duty sewing machine.
- e. Invert canopy inside and align lower edge of foldunder made in (d), above, with lower edge of the original gore section. Allow each side of replacement gore section material to extend ¾ inch beyond outside edges of original gore section radial tapes. Ensure ½-inch wide foldunder faces down. Temporarily secure replacement gore section to original gore section lower edge with pushpins.

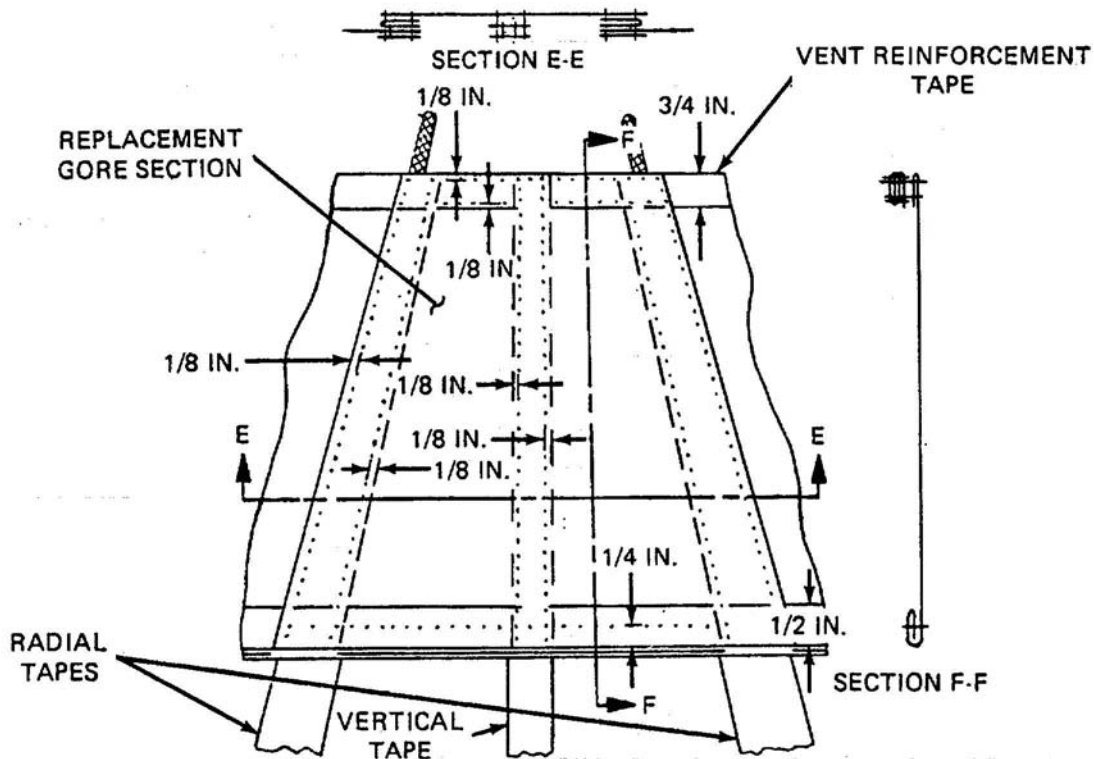

Figure 6. Gore Section 3, Replacement Details.

- f. On each side of replacement gore section material, make a 3/4-inch wide foldunder and align folded edge with outside edge of each original gore section radial tape. Temporarily secure each of the side foldunders with pushpins.
- g. At upper end of replacement gore section, make a doubled 3/4-inch wide foldunder and align upper edge of fold with upper edge of vent reinforcement tape (upper lateral band). Temporarily secure fold-under with pushpins.
- h. Baste edges of replacement gore section in accordance with WP 0012 and remove pushpins.
- i. Using a light-duty sewing machine and size E nylon thread, secure replacement gore section to original gore section radial tapes, vertical tape, and vent reinforcement tape (upper lateral band) with two rows of stitching, using 7 to 11 stitches per inch.
- j. Remove basting, reinvert canopy to outside, and remove original gore section material by cutting up inside of each applicable radial tape, up both sides of vertical tape, and across lower edge of vent reinforcement tape (upper lateral band).

END OF TASK

END OF WORK PACKAGE

SERVICE MAINTENANCE
26-FOOT DIAMETER, HIGH-VELOCITY CARGO PARACHUTE ASSEMBLY
SUSPENSION LINE ATTACHING LOOP
REPLACE

INITIAL SETUP:**Tools**

Knife (WP 0049, Item 5)
 Knife, Hot Metal (WP 0049, Item 6)
 Sewing Machine, Light-Duty (WP 0049, Item 14)
 Sewing Machine, Zig-Zag (WP 0049, Item 15)
 Yardstick (WP 0049, Item 22)

Personnel Required

92R1P Parachute Rigger

Equipment Condition

Inspected (WP 0006)
 Cleaned (WP 0008)
 Shaken (WP 0007)
 Canopy laid out on repair table.

Materials/Parts

Pencil, Marking Aid (WP 0050, Items 21/22)
 Thread, Nylon, Size E (WP 0050, Items 33/34)
 Tape, Nylon, Type III, 3/4 IN (WP 0050, Item 29)

REPLACE

A damaged suspension line attaching loop shall be replaced by fabricating as follows:

- a. Remove original suspension line attaching loop by cutting original radial tape at a point immediately below lower edge of skirt reinforcement tape (lower lateral band).
- b. Cut a 19-inch length of 3/4-inch wide nylon tape and sear ends. Double tape and align ends.
- c. Using a light-duty sewing machine and size E nylon thread, stitch a single row of stitching 1/8 inch from each side along double tape length (Figure 1). Stitching will be 7 to 11 stitches per inch.
- d. Using a suitable marking aid, mark doubled tape length at a point 3 inches from each end.
- e. Center doubled tape length in top loop of suspension line and align both ends of tape above suspension line.
- f. Position one end of tape length under and opposite end of tape length over applicable radial tape and align two 3-inch marks made in (4), above, with lower edge of the skirt reinforcement tape, to form a loop below canopy skirt.
- g. Using a zig-zag sewing machine and size E nylon thread, secure ends of formed loop to radial tape by stitching two 3/16-inch wide by 3-inch long rows of stitching, 1/8 inch from tape edges. Stitching will be 7 to 11 stitches per inch.

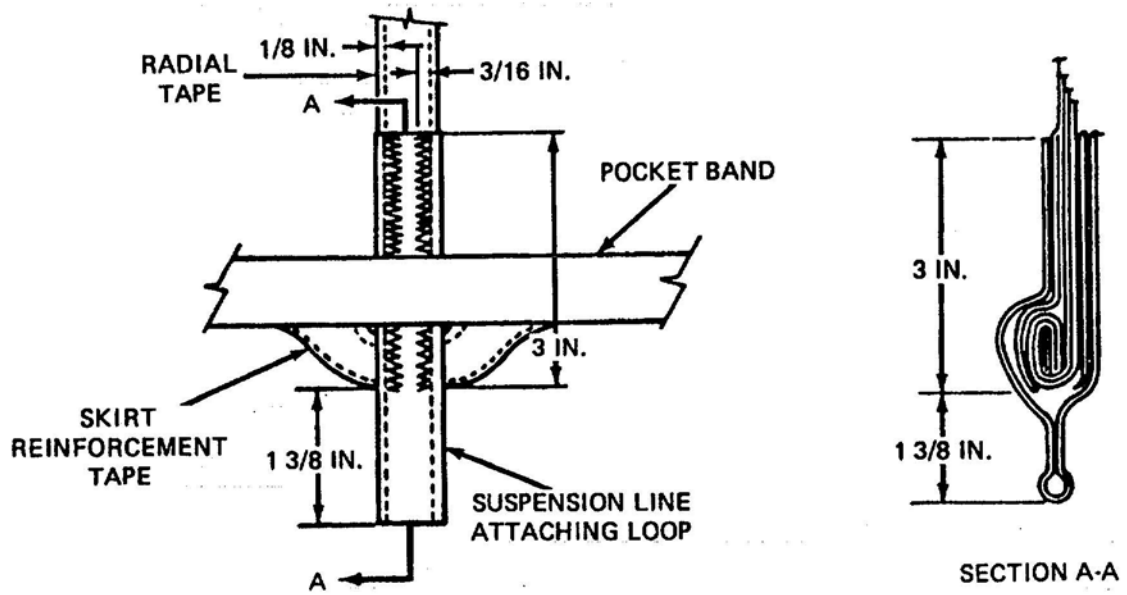

Figure 1. Suspension Line Attaching Loop Replacement Details.

END OF TASK

END OF WORK PACKAGE

SERVICE MAINTENANCE
26-FOOT DIAMETER, HIGH-VELOCITY CARGO PARACHUTE ASSEMBLY
SUSPENSION LINE
REPLACE

INITIAL SETUP:**Tools**

Knife (WP 0049, Item 5)
 Knife, Hot Metal (WP 0049, Item 6)
 Sewing Machine, Zig-Zag (WP 0049, Item 15)
 Splicing Aid (WP 0049, Item 23)
 Yardstick (WP 0049, Item 22)

Personnel Required

92R1P Parachute
 Rigger

Materials/Parts

Cord, Nylon, Type II, Coreless (WP 0050, Item 13)
 Thread, Nylon, Size E (WP 0050, Items 33/34)

Equipment Condition

Inspected (WP 0006)
 Cleaned (WP 0008)
 Shaken (WP 0007)
 Canopy laid flat on repair
 table.

REPLACE

Replace an unserviceable suspension line by fabricating as follows:

1. Place canopy assembly in proper layout on inspection table.
2. Apply partial tension to suspension lines and trace defective suspension line from the riser to suspension line attaching loop at canopy skirt. Upon completion of line tracing, release line tension.
3. Remove original suspension line from canopy and applicable riser by cutting formed loop located on each end of suspension line.
4. Cut a 27-foot length of coreless nylon cord and taper cut each end.
5. Using a suitable marking aid, mark the cord at points 4½, 6½, and 11 inches from one tapered end (Figure 1).
6. Pass 5¾ inches of marked cord through original suspension line attaching loop on canopy skirt.
7. Insert a suitable splicing aid into the cord casing at 11-inch mark and work splicing aid up through cord casing and to outside at the 6½-inch mark (Figure 2).
8. Insert cord tapered end into eye of the splicing aid.
9. Pull splicing aid and cord tapered end down inside cord casing until 4½-inch and 6½-inch marks are aligned (Figure 3).
10. Hold aligned marks together, pull splicing aid and cord tapered end down and to outside at 11-inch mark.

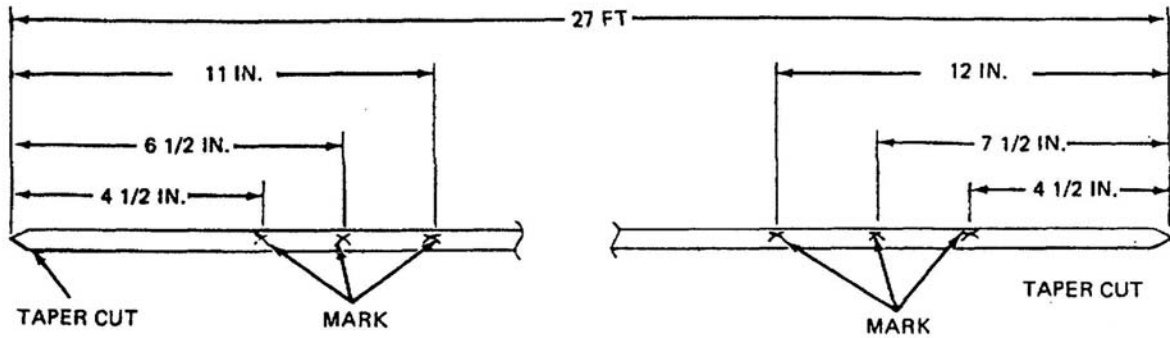

Figure 1. Replacement Suspension Line Construction Details.

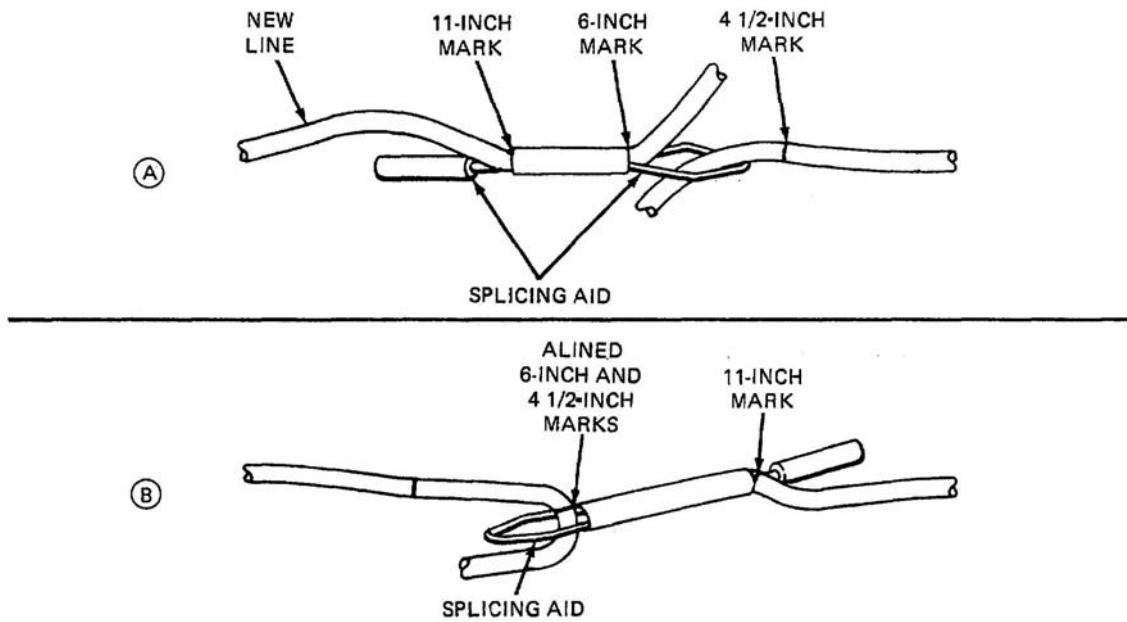

Figure 2. Inserting Splicing Aid into Cord Casing.

11. Remove cord tapered end from splicing aid and, while holding 4 1/2-inch and 6 1/2-inch marks together, pull cord at a point below 11-inch mark to allow cord tapered end to withdraw into cord casing.
12. Beginning at a point 1/2 inch below aligned 4 1/2- and 6 1/2-inch marks, secure formed loop by stitching a 1/8 -inch wide, 2-inch long row of double-throw zig-zag stitching using size E nylon thread. Stitching will be 7 to 11 stitches per inch (Figure 3).

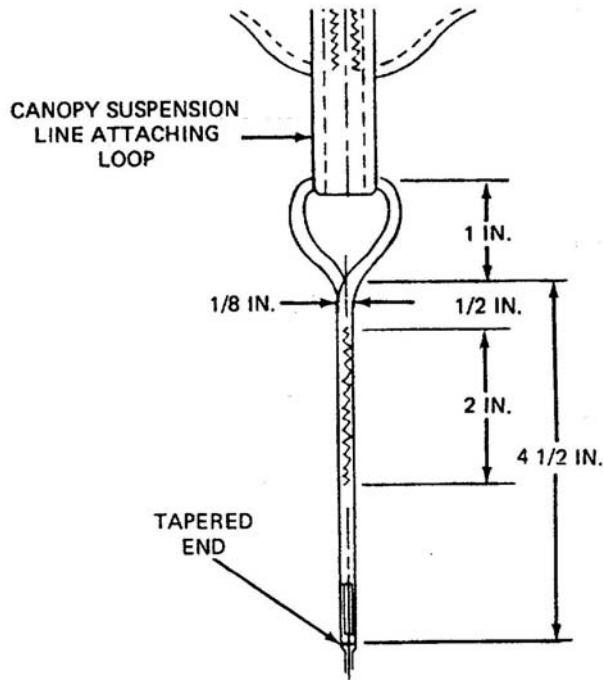

Figure 3. Securing Suspension Line at Suspension Line Attaching Loop.

13. On the running end of the cord length, mark the cord at points $4\frac{1}{2}$, $7\frac{1}{2}$, and 12 inches from the tapered end (Figure 1).
14. Trace replacement suspension line from canopy skirt down to applicable riser suspension line attaching loop.
15. Apply tension to replacement suspension line equal to that of an adjacent suspension line, to ascertain that marks made on the replacement line are located correctly.
16. Release tension on suspension line and attach line length to applicable riser suspension line attaching loop by passing $6\frac{3}{4}$ inches of marked cord through original suspension line attaching loop on riser. Suspension lines shall be attached to riser in numerical sequence (Figure 4).
17. Insert a suitable splicing aid to cord casing at the 12-inch mark and pass inserted aid down through the cord casing and to outside at the $7\frac{1}{2}$ -inch mark, in a manner similar to that shown in Figure 2, but in the opposite direction.
18. Insert cord tapered end into eye of splicing aid.
19. Pull splicing aid and cord tapered end up inside cord casing until the $4\frac{1}{2}$ -inch and $7\frac{1}{2}$ -inch marks are aligned.
20. Hold aligned marks together and pull splicing aid and cord tapered end up and to outside at 12-inch mark.

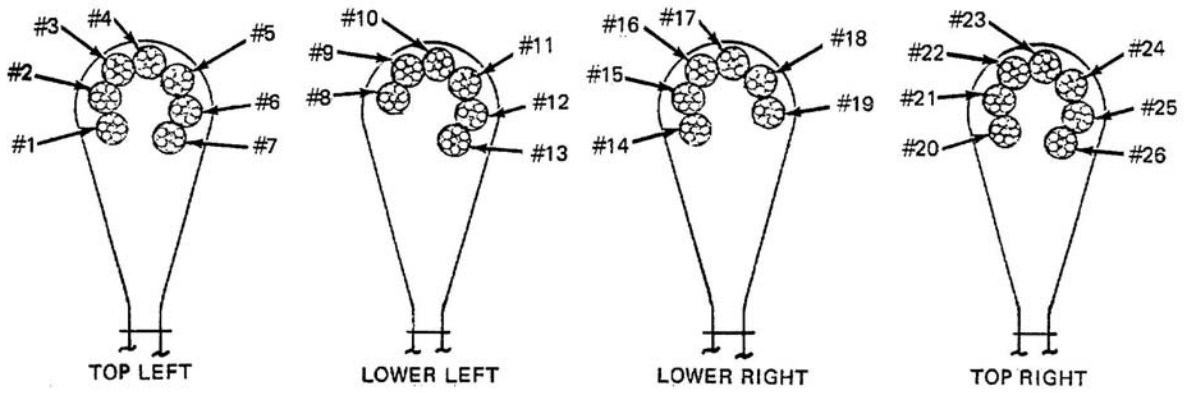

Figure 4. Suspension Line Numerical Sequence.

21. Remove cord tapered end from splicing aid and, while holding 4½-inch and 7½ -inch marks together, pull cord at a point above the 12-inch mark to allow cord tapered end to withdraw into cord casing.
22. Beginning at a point ½ inch above aligned 4½-inch and 7½-inch marks, using a zig-zag sewing machine and size E nylon thread, secure formed loop by stitching a ⅛ -inch wide, 2-inch long row of stitching. Stitching will be 7 to 11 stitches per inch (see Figure 5).

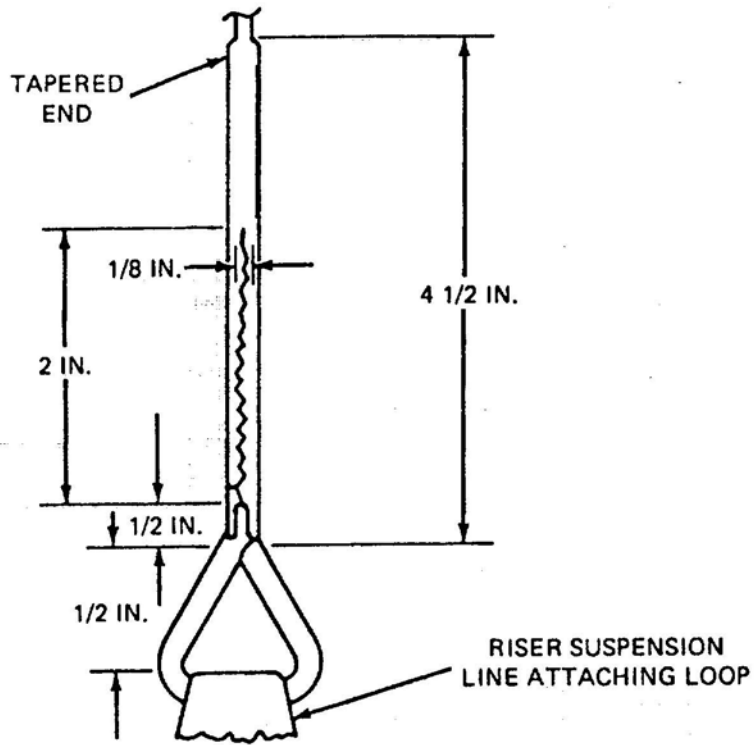

Figure 5. Securing Suspension Line at Riser Suspension Line Attaching Loop.

END OF TASK

END OF WORK PACKAGE

SERVICE MAINTENANCE
26-FOOT DIAMETER, HIGH-VELOCITY CARGO PARACHUTE ASSEMBLY
PREPARATION FOR STORAGE OR SHIPMENT

Storage Criteria

Administrative storage of air delivery equipment will be accomplished in accordance with AR 750-1 and the instructions furnished below.

General Storage Requirements

To ensure that stored air delivery equipment serviceability standards are maintained, every effort will be made to adhere to the following storage requirements:

1. When available, a heated building should be used to store parachutes and other air delivery items.
2. Air delivery equipment will be stored in a dry, well-ventilated location and protected from pilferage, dampness, fire, dirt, insects, rodents, and direct sunlight.
3. Air delivery equipment will not be stored in a manner which would prevent ventilation or interfere with light fixtures, heating vents, fire-fighting devices, cooling units, exits, or fire doors.
4. Air delivery items will not be stored in a damaged, dirty, or damp condition.
5. All stored air delivery items will be marked, segregated, and located for accessibility and easy identification.
6. Air delivery equipment will not be stored in direct contact with any building floor or wall. Storage will be accomplished using bins, shelves, pallets, racks or dunnage to provide airspace between the storage area floor and the equipment. If preconstructed shelving or similar storage accommodations are not available, locally fabricate storage provisions using suitable lumber or wooden boxes.
7. All available materials handling equipment should be used as much as possible in the handling of air delivery items.
8. Periodic rotation of stock, conversion of available space, proper housekeeping policies, and strict adherence to all safety regulations will be practiced at all times.

Storage specifics for parachutes. In addition to the storage requirements stipulated above, following is a list of specific requirements that must be enforced when storing parachutes:

- (1) Except for those assemblies required for contingency operation, parachutes will not be stored in a packed configuration.
- (2) Stored parachute assemblies will be secured from access by unauthorized personnel.
- (3) A parachute which is in storage, and is administered a cyclic repack and inspection, will not be exposed to incandescent light or indirect sunlight for a period of more than 36 hours. Exposure to direct sunlight should be avoided entirely.

In-Storage Inspection

General Information. An in-storage inspection is a physical check conducted on a random sample of parachutes which are located in storage.

Intervals. Parachutes in storage will be inspected at least semiannually and at more frequent intervals if prescribed by the local Airdrop Systems Technician (921A) or Senior Airdrop NCO (92R4P)

and above, under guidance from an Airdrop Systems Technician assigned to the command at the Battalion level or higher, when no Airdrop Technician is assigned at the Company/Detachment/Team level.

Inspection. Inspect to ensure that the parachute is ready for issue.

- (1) Check the parachute for proper identification.
- (2) Check for damage or deterioration.
- (3) Ensure that all modifications or similar requirements have been completed.
- (4) Check the adequacy of the storage facilities, efforts taken to control pests and rodents, and protection against unfavorable climatic conditions.

Shipment

Initial Shipment. The initial packaging and shipping of parachutes is the responsibility of item manufacturers, who are required to comply with federal and military packing specification as stipulated in contractual agreements. Air delivery equipment is normally shipped to depot activities by domestic freight or parcel post, packaged to comply with overseas shipping requirements. Except for those air delivery items which are unpackaged and subjected to random inspections or testing by a depot activity, parachutes received by a using unit will be contained in original packaging materials.

Shipping Between Maintenance Activities. The shipping of air delivery equipment between organizational and direct support maintenance activities will be accomplished on a signature verification basis using whatever means of transportation are available. Used parachutes and other fabric items will be tagged in accordance with DA PAM 738-751, and rolled, folded or placed loosely in a parachute pack, deployment bag, or other suitable container, as required. Used wood and metal air delivery items will be tagged as prescribed in DA PAM 738-751 and placed in a suitable type container, if necessary. Unused air delivery equipment will be transported in original shipping containers. During shipment, every effort will be made to protect air delivery equipment from weather elements, dust, dirt, oil, grease and acids. Vehicles used to transport parachutes will be inspected to ensure the items are protected from the previously cited material-damaging conditions.

Other Shipping Instructions. Air delivery equipment destined for domestic or overseas shipment will be packaged and marked in accordance with AR 700-15 (Packaging of Materiel).

Accordion Folding and Rigger Rolling

Accordion Folding. Parachute canopy assemblies that are not packed for use should be accordion folded prior to entry into storage. To accordion fold a parachute canopy assembly, perform the following:

- (1) Place the parachute canopy in proper layout under partial tension and dress the outside edges of both gore groups.
- (2) Fold the left group of gores over the right group of gores (Figure 1, A). Release tension.

- (3) "Chain" the suspension lines and S-fold the "chained" lines on top of the deployment bag (Figure 1, B).
- (4) Place the lower end of the canopy on top of the S-folded suspension lines and locate the lower edge of the canopy skirt at the lower end of the deployment bag.
- (5) Accordion fold the remaining canopy length neatly on top of the canopy lower end (Figure 1, C). Turn the canopy vent under the last fold.
- (6) Temporarily secure the folded canopy to the deployment bag with available webbing (Figure 1, D).
- (7) Upon completion of the accordion folding process, place the folded parachute assembly in a suitable type container for storage.

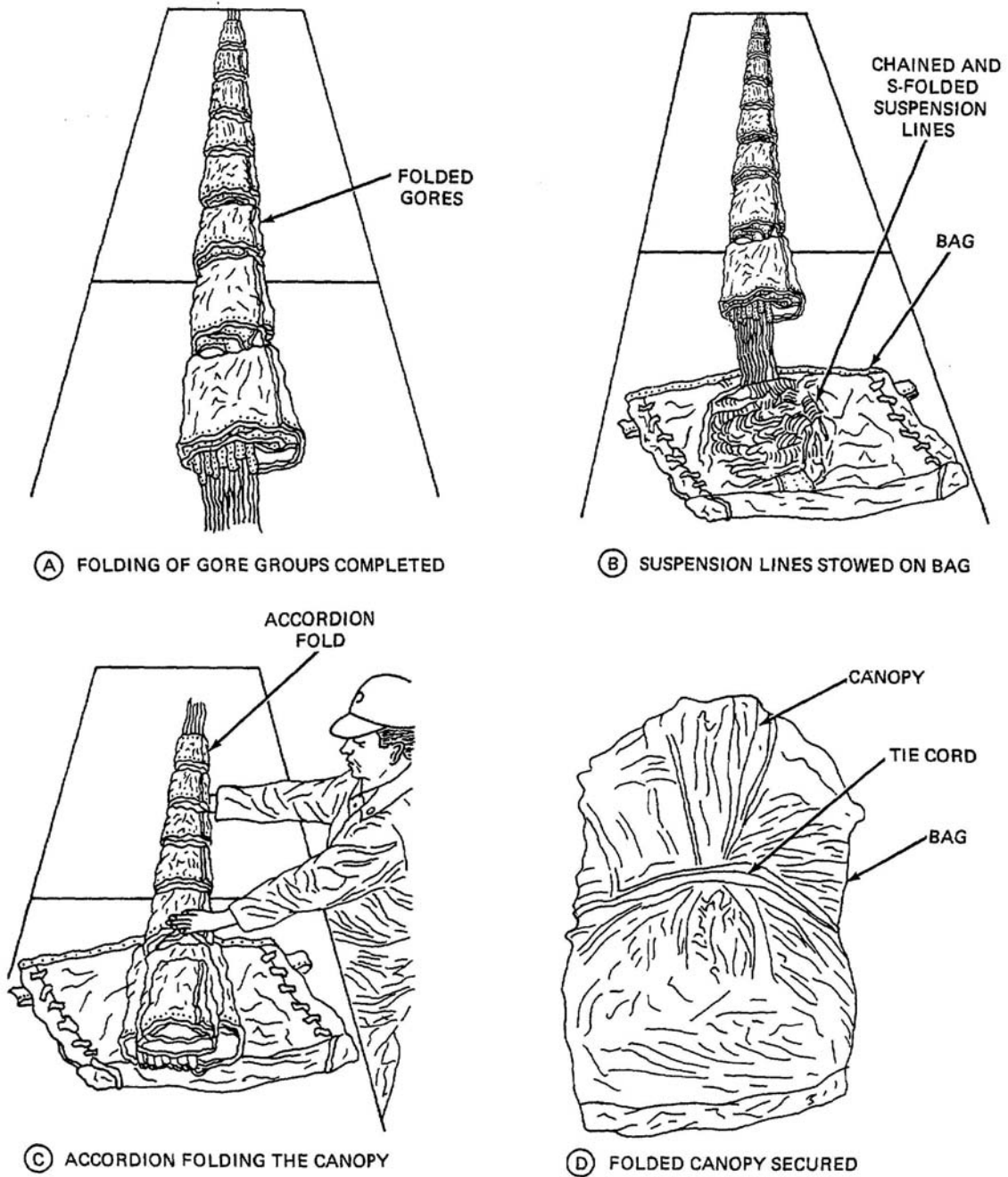

Figure 1, A-D. Accordion Folding a Parachute Canopy Assembly.

Rigger Rolling. Parachute assemblies will be rigger rolled, prior to being sent to or returned from a parachute repair activity, for ease of handling to prevent suspension line entanglement. Rigger roll a parachute as follows:

- (1) Place the parachute in proper layout and apply partial tension.
- (2) Grasp the right and left suspension line groups. Using a fast, circular motion, flip each of the two gore groups up and to the center radial seam. Tighten each gore group roll by hand and bring both rolled gore groups together at the center radial seam (Figure 2, A).
- (3) Release tension and disconnect the canopy vent from the vent attaching device.
- (4) Fold the canopy vent down between the rolled gore groups to a point within 18 inches of the canopy skirt lower edge.
- (5) Beginning at the folded upper end of the canopy, roll the canopy tightly toward the canopy skirt (Figure 2, B). Ensure the width of the rolled canopy does not exceed the width of the parachute deployment bag.
- (6) Continue rolling the canopy toward the lower end of the suspension lines and risers, locating the lines and riser webbing around the center of the roll (Figure 2, C).
- (7) Disconnect the suspensions lines/risers form the attaching device and place the rolled canopy assembly on top of the deployment bag.
- (8) Secure the rolled canopy assembly within the confines of the bag using a suitable type cord (Figure 2, D).

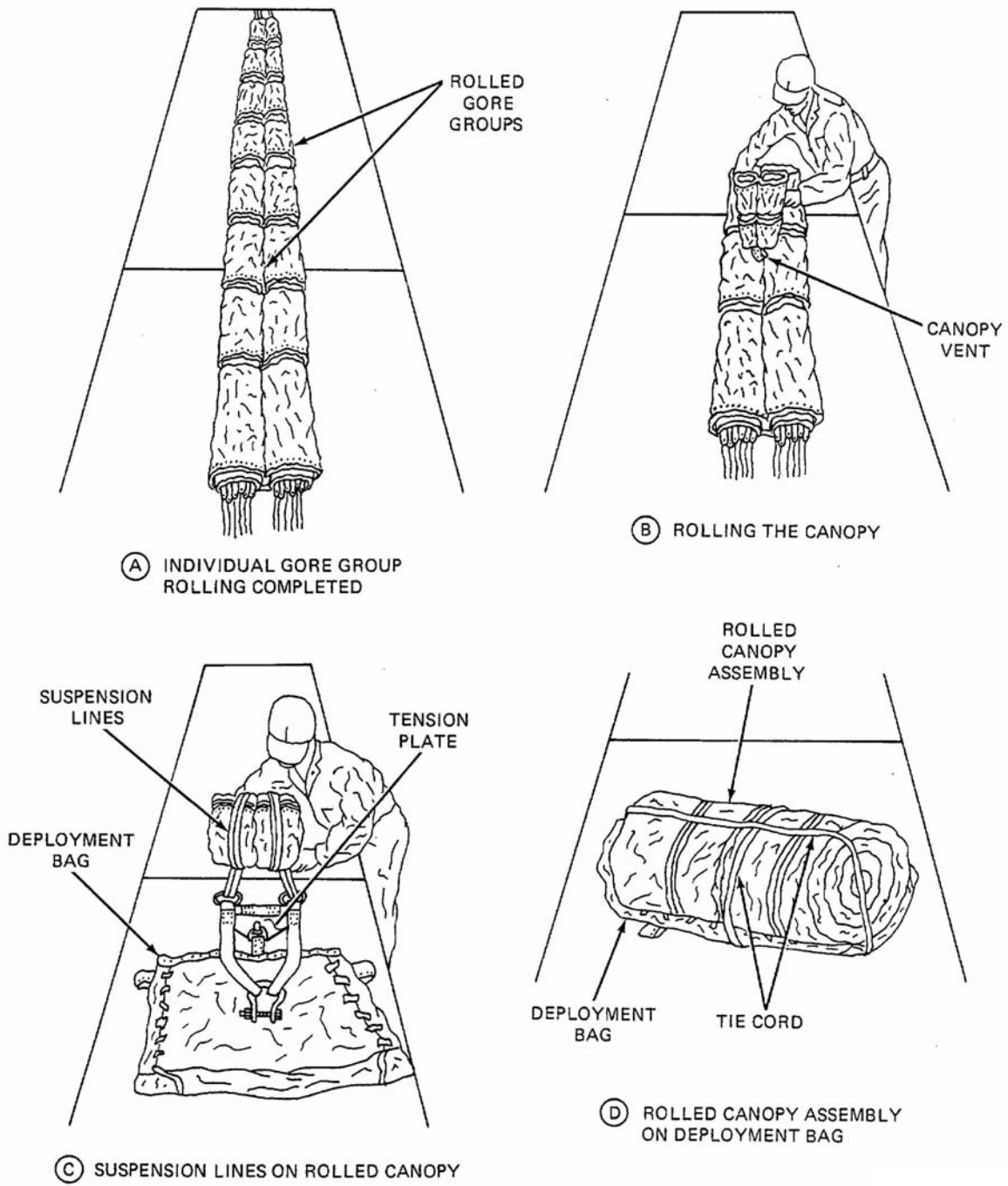

Figure 2, A-D. Rigger Rolling a Parachute Canopy Assembly.

END OF TASK

END OF WORK PACKAGE

CHAPTER 4

PARTS INFORMATION
FOR
PARACHUTE, CARGO TYPE:
26-FOOT DIAMETER, HIGH-VELOCITY

**26-FOOT DIAMETER, HIGH-VELOCITY CARGO PARACHUTE ASSEMBLY
REPAIR PARTS AND SPECIAL TOOLS LIST (RPSTL) INTRODUCTION**

INTRODUCTION

SCOPE

This RPSTL lists and authorizes spares and repair parts; special tools; special test, measurement, and diagnostic equipment (TMDE); and other special support equipment required for performance of Field maintenance of the 26-Foot Diameter, High-Velocity Cargo Parachute. It authorizes the requisitioning, issue, and disposition of spares, repair parts, and special tools as indicated by the source, maintenance, and recoverability (SMR) codes.

GENERAL

In addition to the Introduction work package, this RPSTL is divided into the following work packages.

1. Repair Parts List Work Packages. Work packages containing lists of spares and repair parts authorized by this RPSTL for use in the performance of maintenance. These work packages also include parts which must be removed for replacement of the authorized parts. Parts lists are composed of functional groups in ascending alphanumeric sequence, with the parts in each group listed in ascending figure and item number sequence. Sending units, brackets, filters, and bolts are listed with the component they mount on. Bulk materials are listed by item name in FIG. BULK at the end of the work packages. Repair parts kits are listed separately in their own functional group and work package. Repair parts for reparable special tools are also listed in a separate work package. Items listed are shown on the associated illustrations.

2. Special Tools List Work Packages. Work packages containing lists of special tools, special TMDE, and special support equipment authorized by this RPSTL (as indicated by Basis of Issue (BOI) information in the DESCRIPTION AND USABLE ON CODE (UOC) column). Tools that are components of common tool sets and/or Class VII are not listed.

3. Cross-Reference Indexes Work Packages. There are two cross-reference indexes work packages in this RPSTL: the National Stock Number (NSN) Index work package, and the Part Number (P/N) Index work package. The National Stock Number Index work package refers you to the figure and item number. The Part Number Index work package refers you to the figure and item number.

EXPLANATION OF COLUMNS IN THE REPAIR PARTS LIST AND SPECIAL TOOLS LIST WORK PACKAGES

ITEM NO. (Column (1)). Indicates the number used to identify items called out in the illustration.

SMR CODE (Column (2)). The SMR code containing supply/requisitioning information, maintenance level authorization criteria, and disposition instruction, as shown in the following breakout. This entry may be subdivided into 4 subentries, one for each service.

TABLE 1. SMR Code Explanation.

<u>Source Code</u>	<u>Maintenance Code</u>	<u>Recoverability Code</u>	
<u>XX</u>	<u>XX</u>	<u>X</u>	
1 st two positions: How to get an item.	3 rd position: Who can install, replace, or use the item.	4 th position: Who can do complete repair* on the item.	5 th position: Who determines disposition action on unserviceable items.

*Complete Repair: Maintenance capacity, capability, and authority to perform all corrective maintenance tasks of the "Repair" function in a use/user environment in order to restore serviceability to a failed item.

Source Code. The source code tells you how you get an item needed for maintenance, repair, or overhaul of an end item/equipment. Explanations of source codes follow:

Source Code

Application/Explanation

PA
PB
PC
PD
PE
PF
PG
PH
PR
PZ

NOTE

Items coded PC are subject to deterioration.

KD
KF
KB

Items with these codes are not to be requested/requisitioned individually. They are part of a kit which is authorized to the maintenance level indicated in the third position of the SMR code. The complete kit must be requisitioned and applied.

MO-Made at service/AMC level
MF-Made at field/ASB level
MH-Made at below depot/sustainment level
ML-Made at SRA/TASMG
MG-Navy only

Items with these codes are not to be requisitioned/requested individually. They must be made from bulk material which is identified by the part number in the DESCRIPTION AND USABLE ON CODE (UOC) column and listed in the bulk material group work package of the RPSTL. If the item is authorized to you by the third position code of the SMR code, but the source code indicates it is made at higher level, order the item from the higher level of maintenance.

AO-Assembled by service/AMC level
AF-Assembled by field/ASB level
AH-Assembled by below depot sustainment level
AL-Assembled by SRA/TASMG
AD-Assembled by depot
AG-Navy only

Items with these codes are not to be requested/requisitioned individually. The parts that make up the assembled item must be requisitioned or fabricated and assembled at the level of maintenance indicated by the source code. If the third position of the SMR code authorizes you to replace the item, but the source code indicates the item is assembled at a higher level, order the item from the higher level of maintenance.

XA
XB
XC
XD

Do not requisition an "XA" coded item. Order the next higher assembly. (Refer to NOTE below.)
If an item is not available from salvage, order it using the CAGEC and part number.
Installation drawings, diagrams, instruction sheets, field service drawings; identified by manufacturer's part number.
Item is not stocked. Order an XD-coded item through local purchase or normal supply channels using the CAGEC and part number given, if no NSN is available.

NOTE

Cannibalization or controlled exchange, when authorized, may be used as a source of supply for items with the above source codes except for those items source coded "XA" or those aircraft support items restricted by requirements of R 750-1.

Maintenance Code. Maintenance codes tell you the level(s) of maintenance authorized to use and repair support items. The maintenance codes are entered in the third and fourth positions of the SMR code as follows:

Third Position. The maintenance code entered in the third position tells you the lowest maintenance level authorized to remove, replace, and use an item. The maintenance code entered in the third position will indicate authorization to the following levels of maintenance:

Maintenance Code

Application/Explanation

O* -	Field (Service) level/AMC maintenance can remove, replace, and use the item.
F -	Field /ASB maintenance can remove, replace, and use the item.
H -	Below Depot Sustainment maintenance can remove, replace, and use the item.
L -	Specialized repair activity/TASMG can remove, replace and use the item.
G -	Afloat and ashore intermediate maintenance can remove, replace, and use the item (Navy only).
K -	Contractor facility can remove, replace, and use the item.
Z -	Item is not authorized to be removed, replace, or used at any maintenance level.
D -	Depot can remove, replace, and use the item.
*NOTE - Army may use C in the third position. However, for joint service publications, Army will use O.	

Fourth Position. The maintenance code entered in the fourth position tells you whether or not the item is to be repaired and identifies the lowest maintenance level with the capability to do complete repair (perform all authorized repair functions).

NOTE

Some limited repair may be done on the item at a lower level of maintenance, if authorized by the Maintenance Allocation Chart (MAC) and SMR codes.

Maintenance Code**Application/Explanation**

O -	Field (Service)/AMC is the lowest level that can do complete repair of the item.
F -	Field/ASB is the lowest level that can do complete repair of the item.
H -	Below Depot Sustainment is the lowest level that can do complete repair of the item.
L -	Specialized repair activity/TASMG (enter specialized repair activity or TASMG designator) is the lowest level that can do complete repair of the item.
D -	Depot is the lowest level that can do complete repair of the item.
G -	Both afloat and ashore intermediate levels are capable of complete repair of item. (Navy only).
K -	Complete repair is done at contractor facility.
Z -	Nonreparable. No repair is authorized.
B -	No repair is authorized. No parts or special tools are authorized for maintenance of "B" coded item. However, the item may be reconditioned by adjusting, lubricating, etc., at the user level.

Recoverability Code. Recoverability codes are assigned to items to indicate the disposition action on unserviceable items. The recoverability code is shown in the fifth position of the SMR code as follows:

Recoverability Code**Application/Explanation**

Z -	Nonreparable item. When unserviceable, condemn and dispose of the item at the level of maintenance shown in the third position of the SMR code.
O -	Reparable item. When uneconomically repairable, condemn and dispose of the item at the service/AMC level.
F -	Reparable item. When uneconomically repairable, condemn and dispose of the item at the field level/ASB.
H -	Reparable item. When uneconomically repairable, condemn and dispose of the item at the below depot sustainment level.
D -	Reparable item. When beyond lower level repair capability, return to depot. Condemnation and disposal of item are not authorized below depot level.
L -	Reparable item. Condemnation and disposal not authorized below Specialized Repair Activity (SRA) to theater aviation sustainment maintenance group (TASMG).
A -	Item requires special handling or condemnation procedures because of specific reasons (such as precious metal content, high dollar value, critical material, or hazardous material). Refer to appropriate manuals/directives for specific instructions.
G -	Field level repairable item. Condemn and dispose at either afloat or ashore intermediate levels. (Navy only).
K -	Reparable item. Condemnation and disposal to be performed at contractor facility.

NSN (Column (3)). The NSN for the item is listed in this column.

CAGEC (Column (4)). The Commercial and Government Entity Code (CAGEC) is a five-digit code which is used to identify the manufacturer, distributor, or Government agency/activity that supplies the item.

PART NUMBER (Column (5)). Indicates the primary number used by the manufacturer (individual, company, firm, corporation, or Government activity), which controls the design and characteristics of the item by means of its engineering drawings, specifications, standards, and inspection requirements to identify an item or range of items.

NOTE

When you use an NSN to requisition an item, the item you receive may have a different part number from the number listed.

DESCRIPTION AND USABLE ON CODE (UOC) (Column (6)). This column includes the following information:

1. The federal item name, and when required, a minimum description to identify the item.
2. Part numbers of bulk materials are referenced in this column in the line entry to be manufactured or fabricated.
3. Hardness Critical Item (HCI). A support item that provides the equipment with special protection from electromagnetic pulse (EMP) damage during a nuclear attack.
4. The statement END OF FIGURE appears just below the last item description in column (6) for a given figure in both the repair parts list and special tools list work packages.

QTY (Column (7)). The QTY (quantity per figure) column indicates the quantity of the item used in the breakout shown on the illustration/figure, which is prepared for a functional group, subfunctional group, or an assembly. A "V" appearing in this column instead of a quantity indicates that the quantity is variable and quantity may change from application to application.

EXPLANATION OF CROSS-REFERENCE INDEXES WORK PACKAGES FORMAT AND COLUMNS

1. National Stock Number (NSN) Index Work Package. NSNs in this index are listed in National Item Identification Number (NIIN) sequence.

STOCK NUMBER Column. This column lists the NSN in NIIN sequence. The NIIN consists of the last nine digits of the NSN. When using this column to locate an item, ignore the first four digits of the NSN. However, the complete NSN should be used when ordering items by stock number.

For example, if the NSN is 5385-01-574-1476, the NIIN is 01-574-1476.

FIG. Column. This column lists the number of the figure where the item is identified/located. The figures are in numerical order in the repair parts list and special tools list work packages.

ITEM Column. The item number identifies the item associated with the figure listed in the adjacent FIG. column. This item is also identified by the NSN listed on the same line.

2. Part Number (P/N) Index Work Package. Part numbers in this index are listed in ascending alphanumeric sequence (vertical arrangement of letter and number combinations which places the first letter or digit of each group in order A through Z, followed by the numbers 0 through 9 and each following letter or digit in like order).

PART NUMBER Column. Indicates the part number assigned to the item.

FIG. Column. This column lists the number of the figure where the item is identified/located in the repair parts list and special tools list work packages.

ITEM Column. The item number is the number assigned to the item as it appears in the figure referenced in the adjacent figure number column.

SPECIAL INFORMATION

UOC. The UOC appears in the lower left corner of the Description Column heading. Usable on codes are shown as "UOC:..." in the Description Column (justified left) on the first line under the applicable item/nomenclature. Uncoded items are applicable to all models.

Fabrication Instructions. Bulk materials required to manufacture items are listed in the bulk material functional group of this RPSTL. Part numbers for bulk material are also referenced in the Description Column of the line item entry for the item to be manufactured/fabricated. Detailed fabrication instructions for items source coded to be manufactured or fabricated are found in (enter applicable TM number).

Index Numbers. Items which have the word BULK in the figure column will have an index number shown in the item number column. This index number is a cross-reference between the NSN / Part Number (P/N) Index work packages and the bulk material list in the repair parts list work package.

HOW TO LOCATE REPAIR PARTS

1. When NSNs or Part Numbers Are Not Known.

First. Using the table of contents, determine the assembly group to which the item belongs. This is necessary since figures are prepared for assembly groups and subassembly groups, and lists are divided into the same groups.

Second. Find the figure covering the functional group or the subfunctional group to which the item belongs.

Third. Identify the item on the figure and note the number(s).

Fourth. Look in the repair parts list work packages for the figure and item numbers. The NSNs and part numbers are on the same line as the associated item numbers.

2. When NSN Is Known.

First. If you have the NSN, look in the STOCK NUMBER column of the NSN index work package. The NSN is arranged in NIIN sequence. Note the figure and item number next to the NSN.

Second. Turn to the figure and locate the item number. Verify that the item is the one you are looking for.

3. When Part Number Is Known.

First. If you have the part number and not the NSN, look in the PART NUMBER column of the part number index work package. Identify the figure and item number.

Second. Look up the item on the figure in the applicable repair parts list work package.

26-FOOT DIAMETER, HIGH-VELOCITY CARGO PARACHUTE ASSEMBLY
REPAIR PARTS AND SPECIAL TOOLS LIST (RPSTL)

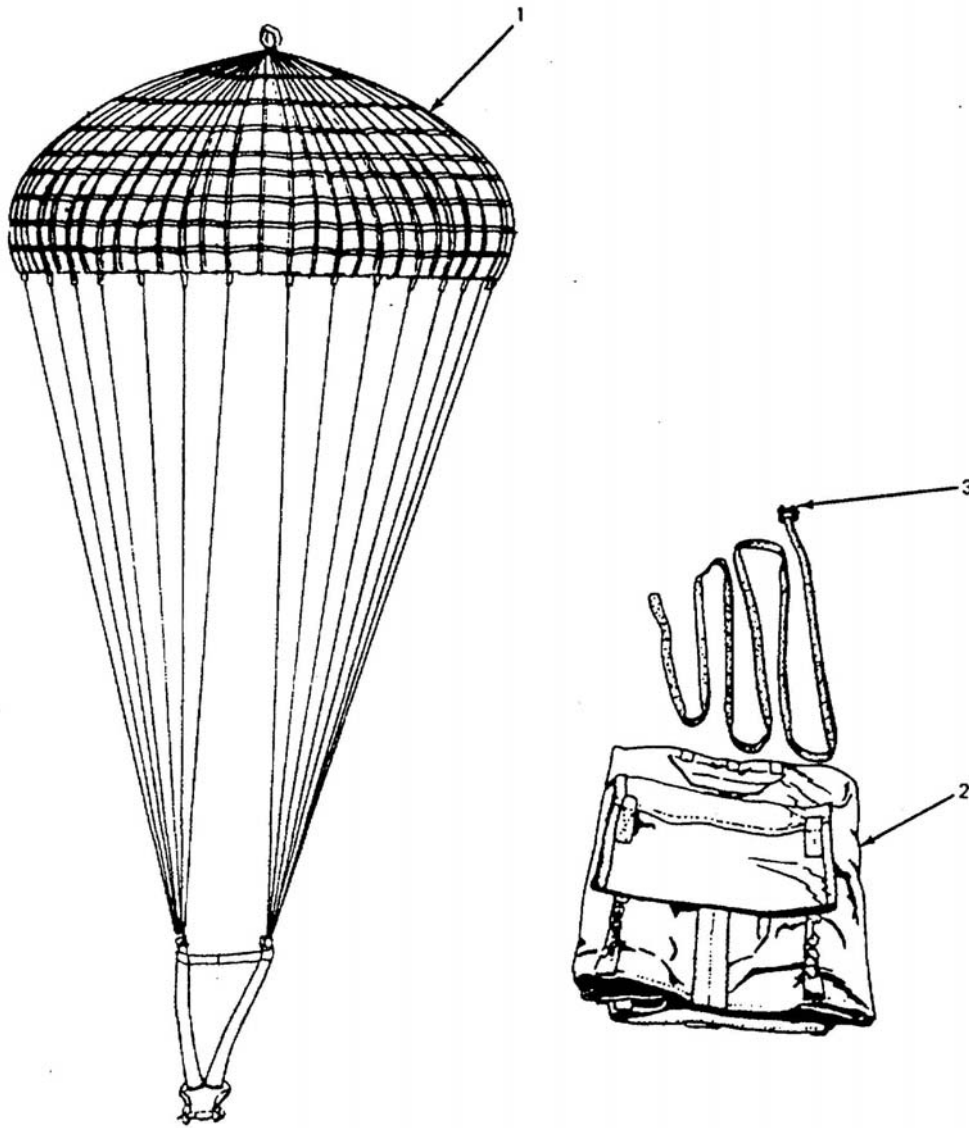

Figure 1. 26-Foot Diameter, High-Velocity Cargo Parachute.

(1) ITEM NO	(2) SMR CODE	(3) NSN	(4) CAGEC	(5) PART NUMBER	(6) DESCRIPTION AND USABLE ON CODE (UOC)	(7) QTY
GROUP 00 26-FOOT DIAMETER, HIGH-VELOCITY CARGO PARACHUTE						
FIG. 1 26-FOOT DIAMETER, HIGH-VELOCITY CARGO PARACHUTE						
1	XAOOO	1670-00-872-6109	81337	11-1-555	CANOPY, CARGO PARACHUTE, 26-FOOT	1
2	PAOOO	1670-01-439-6939	81337	11-1-3954	DEPLOYMENT BAG, PARACHUTE	1
3	MOOOZ	1670-01-136-9820	81337	11-1-219	STATIC LINE, CARGO	1
END OF FIGURE						

26-FOOT DIAMETER, HIGH-VELOCITY CARGO PARACHUTE ASSEMBLY
REPAIR PARTS AND SPECIAL TOOLS LIST (RPSTL)

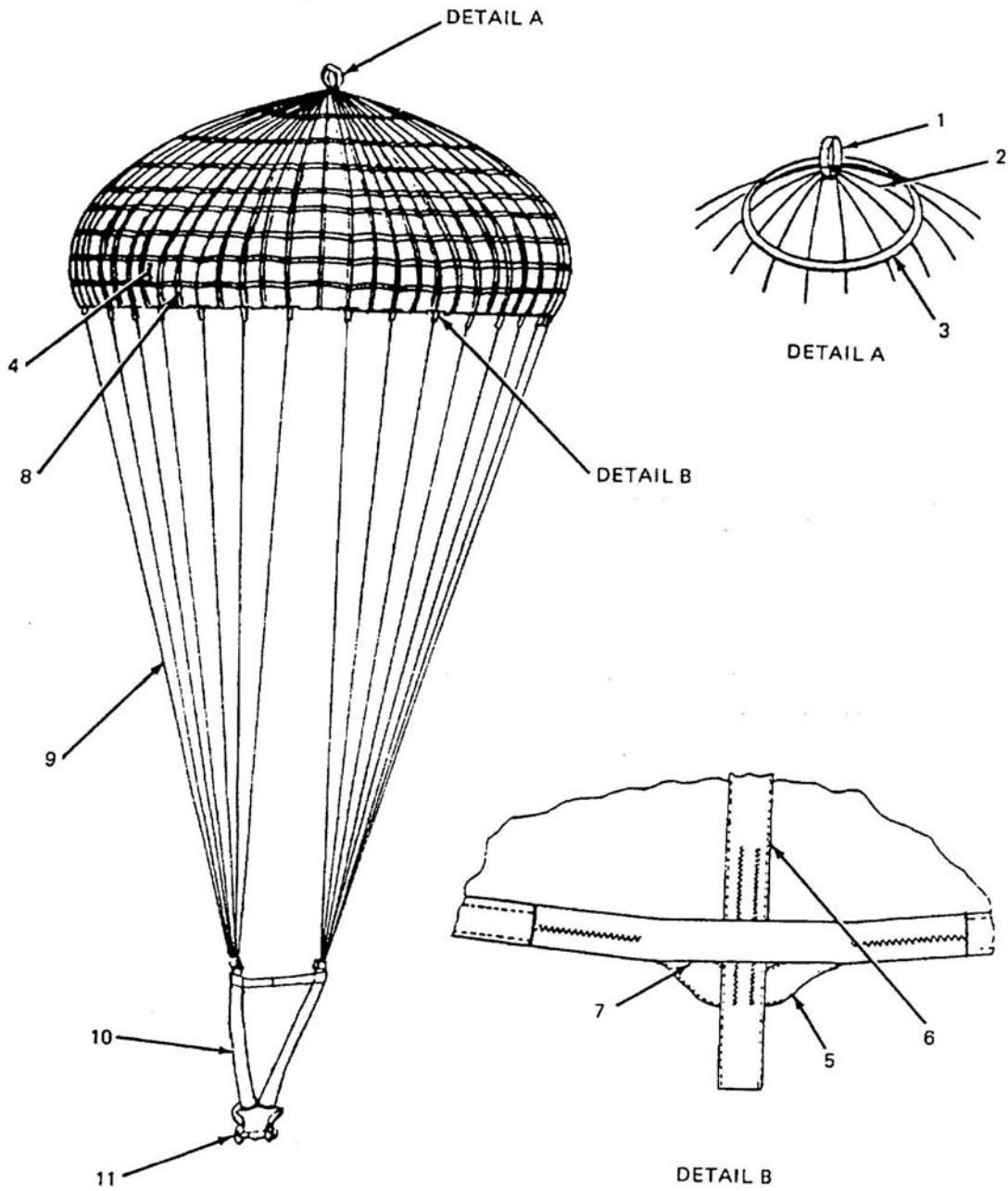

Figure 2. 26-Foot Diameter, High-Velocity Cargo Parachute Canopy.

(1) ITEM NO	(2) SMR CODE	(3) NSN	(4) CAGEC	(5) PART NUMBER	(6) DESCRIPTION AND USABLE ON CODE (UOC)	(7) QTY
GROUP 01 CANOPY						
FIG. 2 CANOPY						
1	MOOOO		81337	11-1-556-15	BRIDLE LOOP, CANOPY, MAKE FROM WEBBING, COTTON, TYPE VIII, CLASS 2B, OD P/N MIL-W-5665 & THREAD, NYLON, TYPE I, CLASS A, SIZE 6, P/N V-T-295	1
2	MOOOO		81337	11-1-556-10VL	VENT LINE, MAKE FROM CORD, NYLON, CORELESS, TYPE II, OD, P/N MIL-C-7515 & THREAD, NYLON, TYPE I, CLASS A, SIZE E, P/N V-T-295	13
3	MOOOO		81337	11-1-556-12VR	VENT, REINFORCEMENT, MAKE FROM TAPE, NYLON, TYPE III, ¼ IN WD, OD, P/N MIL-T-5038 & THREAD, NYLON, TYPE I, CLASS A, SIZE E, P/N V-T-295	1
4	MOOOO		81337	11-1-560-1 thru 8	PANEL, GORE, MAKE FROM CLOTH, SHEETING, POLYESTER & COTTON, TYPE III, CLASS I, STYLE G, 65/35 BLEND, # 128, OG & THREAD, NYLON, TYPE I, CLASS A, SIZE E, P/N V-T-295	208
5	MOOOO		81337	11-1-556-12SR	SKIRT REINFORCEMENT, MAKE FROM TAPE, NYLON, TYPE III, ¼ IN WD, OD, P/N MIL-T-5038 & THREAD, NYLON, TYPE I, CLASS A, SIZE E, P/N V-T-295	1
6	MOOOO		81337	11-1-556-12RT	RADIAL TAPE, MAKE FROM WEBBING, NYLON, TYPE III, ¼ IN W, OD, P/N MIL-T-5038 & THREAD, NYLON, TYPE I, CLASS A, SIZE E, P/N V-T-295	26
7	MOOOO		81337	11-1-556-12PB	POCKET BAND, MAKE FROM TAPE, COTTON, TYPE III, ¼-IN W, OD, P/N MIL-T-5038 & THREAD, TYPE III, ¼ IN WD, OD, P/N MIL-T-5038 & THREAD, NYLON, TYPE I, CLASS A, SIZE E, P/N V-T-295	26
8	MOOOO		81337	11-1-556-11	VERTICAL TAPE, MAKE FROM TAPE, NYLON, TYPE III, ½-IN W. OD, P/N MIL-T-5038 & THREAD, TYPE III, ¼ IN WD, OD, P/N MIL-T-5038 & THREAD, NYLON, TYPE I, CLASS A, SIZE E, P/N V-T-295	26
9	MOOOO		81337	11-1-556-10SL	SUSPENSION LINE, MAKE FROM CORD, NYLON, CORELESS, TYPE II, OD, P/N MIL-C-7515	26
10	MOOOO		81337	11-1-559	RISER, MAKE FROM WEBBING, NYLON, TYPE VIII, CLASS R, OD, P/N MIL-W-4088 & THREAD, NYLON, TYPE I, CLASS A, SIZE 3, P/N V-T-295	1
11	PAOZZ	4030-00-678-8562	96906	PS70087-2	SHACKLE	1
END OF FIGURE						

26-FOOT DIAMETER, HIGH-VELOCITY CARGO PARACHUTE ASSEMBLY
REPAIR PARTS AND SPECIAL TOOLS LIST (RPSTL)

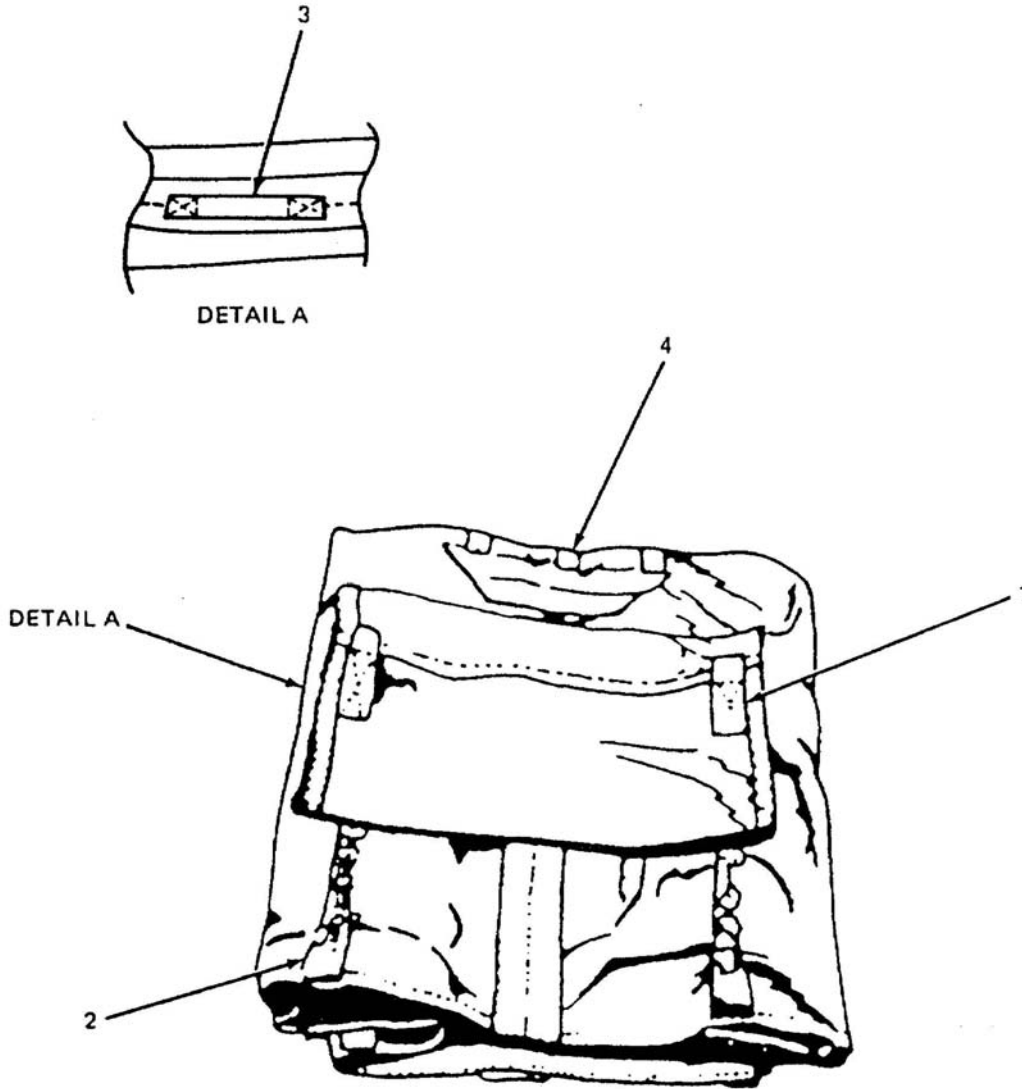

Figure 3. Deployment Bag.

(1) ITEM NO	(2) SMR CODE	(3) NSN	(4) CAGEC	(5) PART NUMBER	(6) DESCRIPTION AND USABLE ON CODE (UOC)	(7) QTY
GROUP 02 BAG, DEPLOYMENT						
FIG. 3 BAG, DEPLOYMENT						
1	MOOOO		81337	11-1-561-E-E	TIE LOOP, PROTECTOR FLAP, MAKE FROM WEBBING, COTTON, TYPE II, CLASS 2B, P/N MIL-W-5665	1
2	MOOOO		81337	11-1-561B-B	SUSPENSION LINE RETAINING STRAP, MAKE FORM WEBBING, COTTON, TYPE II, CLASS 2B, P/N MIL- W-5665	1
3	MOOOO		81337	11-1-561J-J	STATIC LINE RETAINING STRAP, MAKE FROM WEBBING, COTTON, TYPE II, CLASS 2B, P/N MIL-W-5665	1
4	MOOOO		81337	11-1-5601VIEWG	ATTACHING LOOP	1
END OF FIGURE						

26-FOOT DIAMETER, HIGH-VELOCITY CARGO PARACHUTE ASSEMBLY
REPAIR PARTS AND SPECIAL TOOLS LIST (RPSTL)

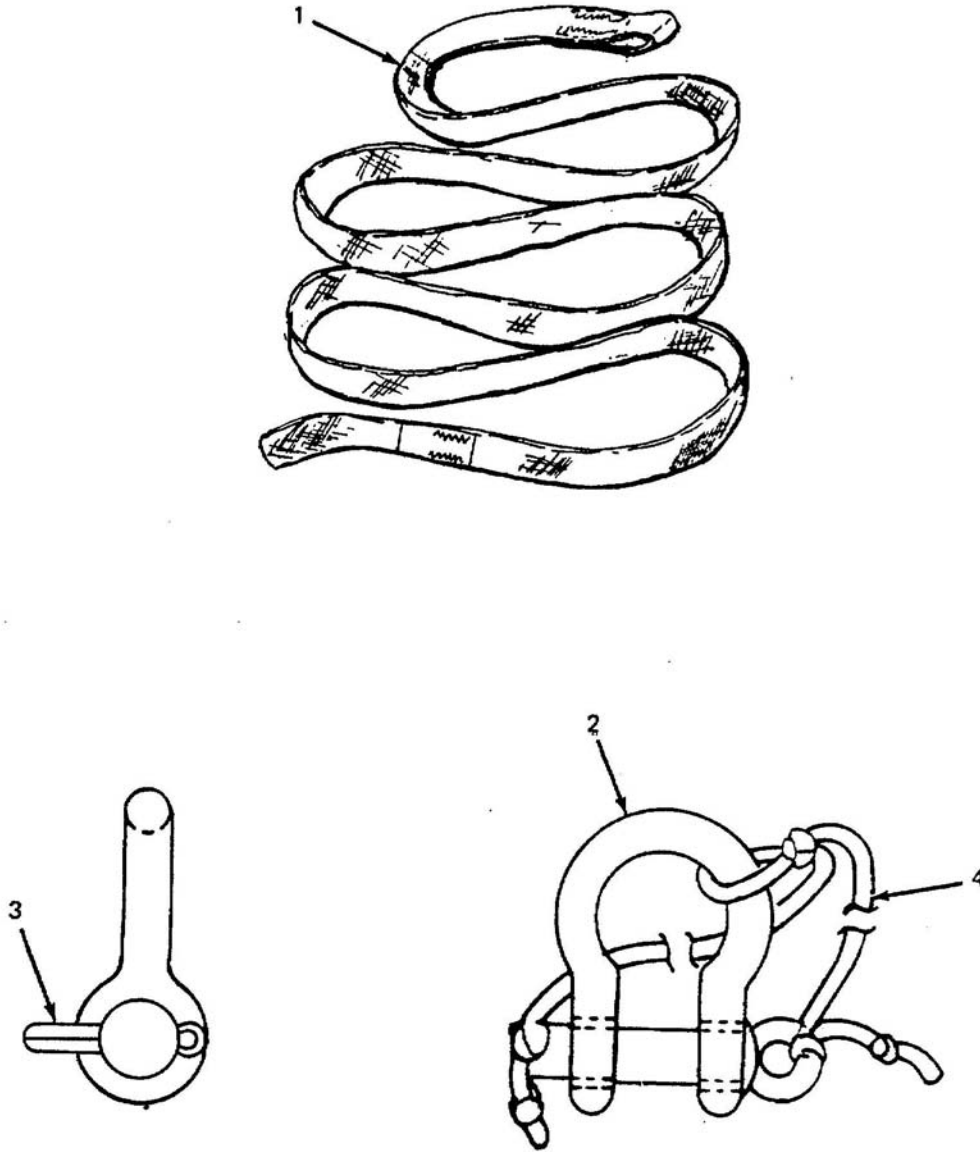

Figure 4. Static Line.

(1) ITEM NO	(2) SMR CODE	(3) NSN	(4) CAGEC	(5) PART NUMBER	(6) DESCRIPTION AND USABLE ON CODE (UOC)	(7) QTY
GROUP 03 STATIC LINE						
FIG. 4 STATIC LINE						
1	MOOOZ	8305-00-082-5751	81337	11-1-219	STATIC LINE, CARGO PARACHUTE, MAKE FROM WEBBING, NYLON, TUBULAR ¾-IN, P/N MIL-W-5625	1
2	PAOOZ	4030-00-678-8560	96906	PS70086-1	CLEVIS, STATIC LINE	1
3	PAOOZ	5315-00-012-0123	96906	MS24665- 355	PIN, COTTER	1
4	MOOOZ	4020-00-240-2154	96906	MIL-C- 5040	CORD, CLEVIS RETAINING, MAKE FROM CORD, NYLON, TYPE I, P/N MIL-C-5040	1
END OF FIGURE						

26-FOOT DIAMETER, HIGH-VELOCITY CARGO PARACHUTE ASSEMBLY
REPAIR PARTS AND SPECIAL TOOLS LIST (RPSTL)

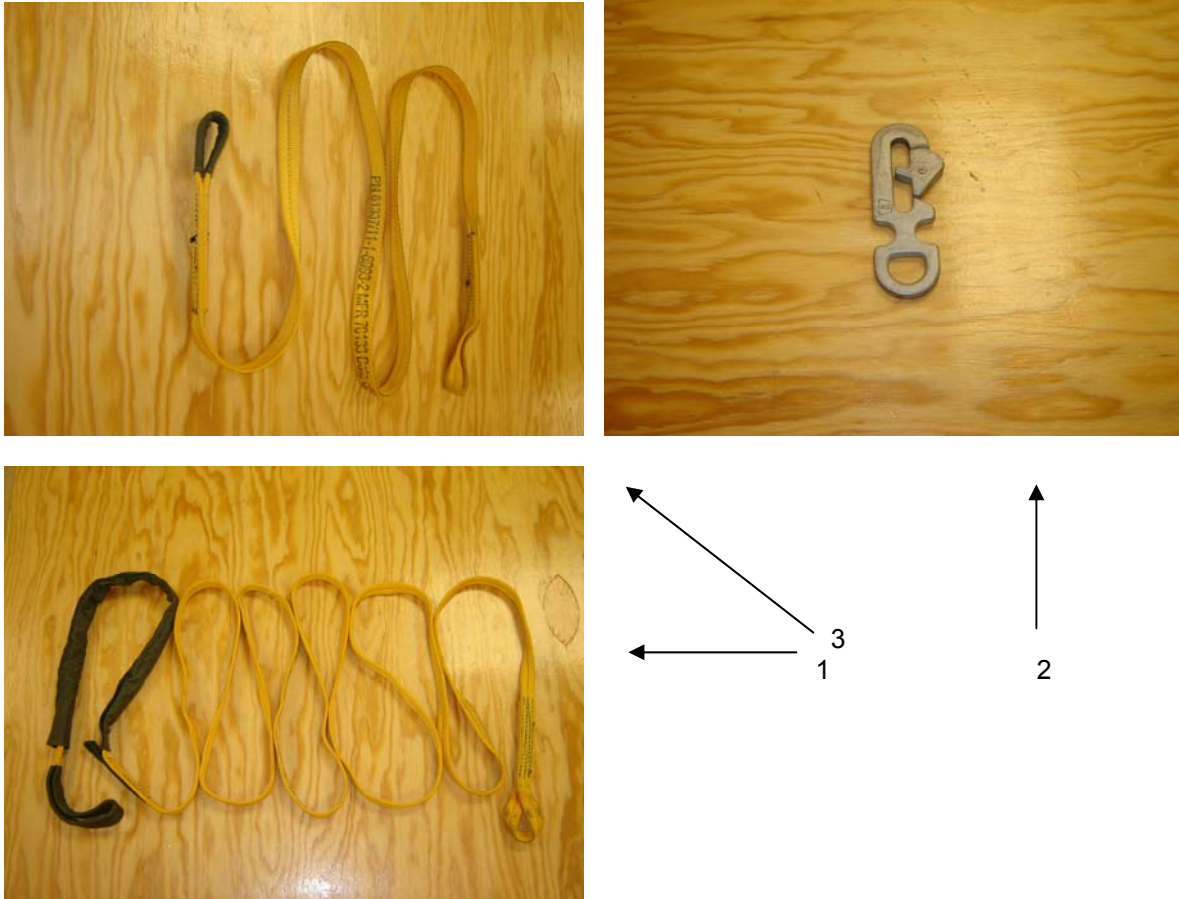

Figure 5. Universal Static Line (USL).

(1) ITEM NO	(2) SMR CODE	(3) NSN	(4) CAGEC	(5) PART NUMBER	(6) DESCRIPTION AND USABLE ON CODE (UOC)	(7) QTY
					GROUP 04 STATIC LINE, USL	
					FIG. 5 STATIC LINE, USL	
1	PAOOZ	1670-01-535-2252	81337	11-1-6993-1	UNIVERSAL STATIC LINE, CARGO PARACHUTE	1
2	PAOOZ	1670-01-476-3142	81337	11-1-6991-1	STATIC LINE, SNAP, USL	1
3	PAOZZ	1670-01-476-3130	81337	11-1-6993-2	STATIC LINE EXTENSION, PERSONAL	1
					END OF FIGURE	

**26-FOOT DIAMETER, HIGH-VELOCITY CARGO PARACHUTE ASSEMBLY
REPAIR PARTS AND SPECIAL TOOLS LIST (RPSTL)**

BULK MATERIAL

(1) ITEM NO	(2) SMR CODE	(3) NSN	(4) CAGEC	(5) PART NUMBER	(6) DESCRIPTION AND USABLE ON CODE (UOC)	(7) QTY
GROUP BULK MATERIAL						
FIG. BULK						
1	PAOZZ	8305-01-497-1230	81349	A-A-50145	COTTON, MUSLIN, 3.5 OZ., 60 IN. WIDE	YD
2	PAOOZ	4020-00-262-2020	81349	MIL-C-7515	CORD, NYLON, CORELESS, TYPE IV, OD	SL
3	PAOOZ	4020-00-240-2154	81349	MIL-C-5040	CORD, NYLON, TYPE I	YD
4	PAOZZ	8315-00-255-7673	81349	MIL-T-5038	TAPE, NYLON, TYPE III, ½ IN W, OD	YD
5	PAOZZ	8315-00-176-8083	81349	MIL-T-5038	TAPE, NYLON, TYPE III, ¾ IN W, OD	YD
6	PAOZZ	8310-00-262-2770	81348	V-T-295	THREAD, NYLON, TYPE I, CLASS A, SIZE E, OD	TU
7	PAOZZ	8310-00-227-1244	81348	V-T-295	THREAD, NYLON, TYPE I, CLASS A, SIZE FF, OD	TU
8	PAOZZ	8310-00-248-9714	81348	V-T-295	THREAD, NYLON, TYPE I, CLASS A, SIZE 3, OD	TU
9	PAOZZ	8305-00-262-2780	81348	V-T-295	THREAD, NYLON, TYPE I, CLASS A, SIZE 6, OD	TU
10	PAOZZ	8305-00-260-2565	81349	MIL-W-5665	WEBBING, COTTON, TYPE VIII, CLASS 2B, OD	YD
11	PAOZZ	8305-00-261-8585	81349	MIL-W-4088	WEBBING, NYLON, TYPE VIII, CLASS R, OD	FT
12	PAOZZ	8305-00-082-5751	81349	MIL-T-5625	WEBBING, NYLON, TUBULAR, ¾ IN W, OD, TYPE	YD
13	PAOZZ	8305-00-281-3315	81349	MIL-W-5665	WEBBING, COTTON, TYPE II	YD
14	PAOZZ	8305-00-261-8579	81349	MIL-T-5038	WEBBING, NYLON, TYPE IV	YD
END OF FIGURE						

26-FOOT DIAMETER, HIGH-VELOCITY CARGO PARACHUTE ASSEMBLY
SPECIAL TOOLS LIST

No Special Tools are Required.

**26-FOOT DIAMETER, HIGH-VELOCITY CARGO PARACHUTE ASSEMBLY
NATIONAL STOCK NUMBER INDEX**

STOCK NUMBER	FIG.	ITEM
5315-00-012-0123	4	3
8305-00-082-5751	4	1
	BULK	12
8315-00-176-8083	BULK	5
8310-00-227-1244	BULK	7
4020-00-240-2154	BULK	3
	4	4
8310-00-248-9714	BULK	8
8315-00-255-7673	BULK	4
8305-00-260-2565	BULK	10
8305-00-261-8579	BULK	14
8305-00-261-8585	BULK	11
4020-00-262-2020	BULK	2
8310-00-262-2770	BULK	6
8305-00-262-2780	BULK	9
8305-00-281-3315	BULK	13
4030-00-678-8560	4	2
4030-00-678-8562	2	11
1670-00-872-6109	1	1
1670-01-136-9820	1	3
1670-01-439-6939	1	2
1670-01-476-3130	5	3
1670-01-476-3142	5	2
8305-01-497-1230	BULK	1
1670-01-535-2252	5	1

26-FOOT DIAMETER HIGH-VELOCITY CARGO PARACHUTE ASSEMBLY
PART NUMBER INDEX

PART NUMBER	FIGURE	ITEM
11-1-219	1	3
	4	1
11-1-555	1	1
11-1-556-15	2	1
11-1-556-10SL	2	9
11-1-556-1OVL	2	2
11-1-556-11	2	8
11-1-556-12PB	2	7
11-1-556-12RT	2	6
11-1-556-12SR	2	5
11-1-556-12VR	2	3
11-1-559	2	10
11-1-560-1 thru 8	2	4
11-1-561B-B	3	2
11-1-561-E-E	3	1
11-1-561J-J	3	3
11-1-3954	1	2
11-1-5601VIEWG	3	4
11-1-6991-1	5	2
11-1-6993-1	5	1
11-1-6993-2	5	3
MILC-4279	BULK	1
MIL-C-5040	BULK	3
	4	4
MIL-C-7515	BULK	2
MIL-T-5038	BULK	4
	BULK	5
	BULK	14
MIL-T-5625	BULK	12
MIL-T-27265	BULK	11
MIL-W-4088	BULK	13
MIL-W-5665	BULK	10
MS24665-355	4	3
	BULK	15
PS70086-1	4	2

PART NUMBER	FIGURE	ITEM
PS70087-2	2	11
V-T-295	BULK	6
	BULK	7
	BULK	8
	BULK	9

CHAPTER 5

SUPPORTING INFORMATION
FOR
PARACHUTE, CARGO TYPE:
26-FOOT DIAMETER, HIGH-VELOCITY

**26-FOOT DIAMETER, HIGH-VELOCITY CARGO PARACHUTE ASSEMBLY
REFERENCES**

Scope

This appendix lists all forms, technical manuals, and miscellaneous publications referenced in, or to be used with, this manual.

Publication indexes

The following publication indexes should be consulted frequently for the latest changes or revisions of references given in this appendix and for new publications relating to the material covered in this manual.

Consolidated Index Of Army Publications And Blank Forms.....DA PAM 25-30

The Army Maintenance Management System (TAMMS).....DA PAM 750-8

The Army Maintenance Management System Users Manual
(TAMMS)-A.....DA PAM 738-751

Technical Manuals

Procedures for the Destruction of Air Delivery Equipment to
Prevent Enemy Use.....TM 43-0002-1

General Maintenance of Parachutes and Other Airdrop Equipment.....TM 10-1670-201-23

.....T.O. 13C-1-41

.....NAVAIR 13-1-17

Field Manuals

First Aid for Soldiers.....FM 4-25.11

Army Regulations

Department of Defense Dictionary of Military and Associated
Terms.....Joint Pub 1-02

Authorized Abbreviation, Brevity Codes and Acronyms.....AR 25-52

Packaging of Materiel.....AR 700-15

Army Materiel Maintenance Policy.....AR 750-1

Airdrop, Parachute Recovery and Aircraft Personnel
Escape SystemsAR 750-32

Technical Bulletins

Maintenance Expenditure Limits for FSC Group 16 (FSC Class 1670).....TB 43-0002-43

Use of Material Condition Tags and Labels on Army Aeronautical and
Air Delivery Equipment.....TB 750-126

Joint Regulations

Joint Airdrop Inspection Records, Malfunction Investigations, and
 Activity Reporting..... AFS 13-210 (I)
AR 59-4
OPNAVINST 4630.24C

Forms

Army Parachute Log Record.....DA Form 3912
AFTO 391
 Equipment Inspection and Maintenance Worksheet.....DA Form 2404
 Report of Discrepancy (ROD).....SF 364
 Product Quality Deficiency Report (PQDR).....SF 368
MCO 4855.10B
 Parachute History Record.....NAVWPNCCE
NAVWPNS CL 13512/11

Miscellaneous

Expendable/Durable Items (Except Medical, Class V Repair Parts,
 and Heraldic Items).....CTA 50-970
 Field and Garrison Furnishings and Equipment.....CTA 50-909
 Army Medical Department Expendable/Durable Items.....CTA 8-100
 Deployment Bag Maintenance Advisory Message.....MAM-ATCOM 96-15

**FIELD MAINTENANCE
26-FOOT DIAMETER, HIGH-VELOCITY CARGO PARACHUTE
MAINTENANCE ALLOCATION CHART**

**MAINTENANCE ALLOCATION CHART (MAC)
INTRODUCTION**

The Army Maintenance System MAC

This introduction provides a general explanation of all maintenance and repair functions authorized at the two maintenance levels under the Two-Level Maintenance System concept.

This MAC (immediately following the introduction) designates overall authority and responsibility for the performance of maintenance functions on the identified end item or component. The application of the maintenance functions to the end item or component shall be consistent with the capacities and capabilities of the designated maintenance levels, which are shown on the MAC in column (4) as:

Field - includes three subcolumns, Crew (C), Service (O), and Field (F).
Sustainment – includes two subcolumns, Below Depot (H) and Depot (D).

The maintenance to be performed below depot and in the field is described as follows:

1. Service maintenance. The responsibility of a using organization to perform maintenance on its assigned equipment. It normally consists of inspecting, servicing, lubricating, adjusting, and replacing parts, minor assemblies, and subassemblies. The replace function for this level of maintenance is indicated by the letter "O" in the third position of the SMR code. An "O" appearing in the fourth position of the SMR code indicates complete repair is possible at the service maintenance level.
2. Field maintenance. Maintenance accomplished on a component, accessory, assembly, subassembly, plug-in unit, or other portion, either on the system or after it is removed. The replace function for this level of maintenance is indicated by the letter "F" appearing in the third position of the SMR code. An "F" appearing in the fourth position of the SMR code indicates complete repair is possible at the field maintenance level. Items are returned to the user after maintenance is performed at this level.
3. Below Depot sustainment. Maintenance accomplished on a component, accessory, assembly, subassembly, plug-in unit, or other portion, either on the system or after is removed. The replace function for this level of maintenance is indicated by the letter "H" appearing in the third position of the SMR code. An "H" appearing in the fourth position of the SMR code indicates complete repair is possible at the below depot sustainment maintenance level. Items are returned to the supply system after maintenance is performed at this level. The tools and test equipment requirements table (immediately following the MAC) lists the tools and test equipment (both special tools and common tool sets) required for each maintenance function as referenced from the MAC. The remarks table (immediately following the tools and test equipment requirements) contains supplemental instructions and explanatory notes for a particular maintenance function.

Maintenance Functions

Maintenance functions are limited to and defined as follows:

1. Inspect. To determine the serviceability of an item by comparing its physical, mechanical, and/or electrical characteristics with established standards through examination (e.g., by sight, sound, or feel.) This includes scheduled inspection and gaugings and evaluation of cannon tubes.

2. Test. To verify serviceability by measuring the mechanical, pneumatic, hydraulic, or electrical characteristics of an item and comparing those characteristics with prescribed standards on a scheduled basis, i.e., load testing of lift devices and hydrostatic testing of pressure hoses.
3. Service. Operations required periodically to keep an item in proper operating condition, e.g. to clean (includes decontaminate, when required), to preserve, to drain, to paint, or to replenish fuel, lubricants, chemical fluids, or gases. This includes scheduled exercising and purging of recoil mechanisms. The following are examples of service functions:
 - a. Unpack. To remove from packing box for service or when required for the performance of maintenance operations.
 - b. Repack. To return item to packing box after service and other maintenance operations.
 - c. Clean. To rid the item of contamination.
 - d. Touch up. To spot paint scratched or blistered surfaces.
 - e. Mark. To restore obliterated identification.
4. Adjust. To maintain or regulate, within prescribed limits, by bringing into proper position, or by setting the operating characteristics to specified parameters.
5. Align. To adjust specified variable elements of an item to bring about optimum or desired performance
6. Calibrate. To determine and cause corrections to be made or to be adjusted on instruments of test, measuring, and diagnostic equipment used in precision measurement. Consists of comparisons of two instruments, one of which is a certified standard of known accuracy, to detect and adjust any discrepancy in the accuracy of the instrument being compared.
7. Remove/Install. To remove and install the same item when required to perform service or other maintenance functions. Install may be the act of emplacing, seating, or fixing into position a spare, repair part, or module (component or assembly) in a manner to allow the proper functioning of an equipment or system.
8. Paint (ammunition only). To prepare and spray color coats of paint so that the ammunition can be identified and protected. The color indicating primary use is applied, preferably, to the entire exterior surface as the background color of the item. Other markings are to be repainted as original so as to retain proper ammunition identification.
9. Replace. To remove an unserviceable item and install a serviceable counterpart in its place. "Replace" is authorized by the MAC and assigned maintenance level is shown as the third position code of the Source, Maintenance and Recoverability (SMR) code.
10. Repair. The application of maintenance services, including fault location/troubleshooting, removal/installation, disassembly/assembly procedures and maintenance actions to identify troubles and restore serviceability to an item by correcting specific damage, fault, malfunction, or failure in a part, subassembly, module (component or assembly), end item, or system.

NOTE

The following definitions are applicable to the "repair" maintenance function: Services. Inspect, test, service, adjust, align, calibrate, and/or replace.

Fault location/troubleshooting. The process of investigating and detecting the cause of equipment malfunctioning; the act of isolating a fault within a system or Unit Under Test (UUT).

Disassembly/assembly. The step-by-step breakdown (taking apart) of a spare/functional group coded item to the level of its least component, that is assigned an SMR code for the level of maintenance under consideration (i.e. identified as maintenance significant).

Actions. Welding, grinding, riveting, straightening, facing, machining, and/or resurfacing.

11. Overhaul. That maintenance effort (service/action) prescribed to restore an item to a completely serviceable/operational condition as required by maintenance standards in appropriate technical publications. Overhaul is normally the highest degree of maintenance performed by the Army. Overhaul does not normally return an item to like new condition.
12. Rebuild. Consists of those services/actions necessary for the restoration of unserviceable equipment to a like new condition in accordance with original manufacturing standards. Rebuild is the highest degree of material maintenance applied to Army equipment. The rebuild operation includes the act of returning to zero those age measurements (e.g., hours/miles) considered in classifying Army equipment/components.

Explanation of Columns in the MAC

Column (1) Group Number. Column (1) lists Functional Group Code (FGC) numbers, the purpose of which is to identify maintenance significant components, assemblies, subassemblies, and modules with the Next Higher Assembly (NHA).

Column (2) Component/Assembly. Column (2) contains the item names of components, assemblies, subassemblies, and modules for which maintenance is authorized.

Column (3) Maintenance Function. Column (3) lists the functions to be performed on the item listed in column (2). (For a detailed explanation of these functions refer to "Maintenance Functions" outlined above).

Column (4) Maintenance Level. Column (4) specifies each level of maintenance authorized to perform each function listed in column (3), by indicating work time required (expressed as manhours in whole hours or decimals) in the appropriate subcolumn. This work time figure represents the active time required to perform that maintenance function at the indicated level of maintenance. If the number or complexity of the tasks within the listed maintenance function varies at different maintenance levels, appropriate work time figures are to be shown for each level. The work time figure represents the average time required to restore an item (assembly, subassembly, component, module, end item, or system) to a serviceable condition under typical field operating conditions. This time includes preparation time (including any necessary disassembly/assembly time), troubleshooting/fault location time, and quality assurance time in addition to the time required to perform the specific tasks identified for the maintenance functions authorized in the MAC. The symbol designations for the various maintenance levels are as follows:

Field:

- C Crew maintenance
- O Service maintenance
- F Field maintenance

Sustainment:

- L Specialized Repair Activity (SRA)
- H Below Depot
- D Depot Maintenance

NOTE

The "L" maintenance level is not included in column (4) of the MAC. Functions to this level of maintenance are identified by work time figure in the "H" column of column (4), and an associated reference code is used in the REMARKS column (6). This code is keyed to the Remarks, and the SRA complete repair application is explained there.

Column (5) Tools and Equipment Reference Code. Column (5) specifies, by code, those common tool sets (not individual tools), common Test, Measurement and Diagnostic Equipment (TMDE), and special tools, special TMDE, and special support equipment required to perform the designated function. Codes are keyed to the entries in the tools and test equipment table.

Column (6) Remarks Code. When applicable, this column contains a letter code, in alphabetic order, which is keyed to the remarks table entries.

Explanation of Columns in the Tools and Test Equipment Requirements

Column (1) – Tool or Test Equipment Reference Code. The tool or test equipment reference code correlates with a code used in column (5) of the MAC.

Column (2) – Maintenance Level. The lowest level of maintenance authorized to use the tool or test equipment.

Column (3) – Nomenclature. Name or identification of the tool or test equipment.

Column (4) – National Stock Number (NSN). The NSN of the tool or test equipment.

Column (5) – Tool Number. The manufacturer's part number.

Explanation of Columns in the Remarks

Column (1) – Remarks Code. The code recorded in column (6) of the MAC.

Column (2) – Remarks. This column lists information pertinent to the maintenance function being performed as indicated in the MAC.

**FIELD MAINTENANCE
26-F00T DIAMETER, HIGH-VELOCITY CARGO PARACHUTE**

Table 1. Maintenance Allocation Chart for 26-Foot Diameter Parachute Assembly.

(1) Group Number	(2) Component/ Assembly	(3) Maintenance Function	(4) Maintenance Level					(5) Tools & Equipment Reference Code	(6) Remarks Code
			Field			Sustainment			
			Crew	Service	Field	Below Depot	Depot		
			C	O	F	H	D		
00	THE 26-FOOT DIAMETER, HIGH - VELOCITY CARGO PARACHUTE							1,2,3,4	A,B,C,D
01	CANOPY	Inspect Service Repair		0.8 0.3 0.3					
0101	LOOP, BRIDLE	Repair Replace		0.1 0.3				5,6	D
0102	LINE, VENT	Repair Replace		0.1 0.4					
0103	TAPE, VENT REINFORCEMENT (UPPER LATERAL BAND)	Repair		0.2					
0104	SECTION, GORE	Repair Replace		0.5 1.0				15,18	
0105	TAPE, RADIAL	Repair		0.1					
0106	TAPE, VERTICAL	Repair		0.2					
0107	TAPE, SKIRT REINFORCEMENT (LOWER LATERAL BAND)	Repair		0.1 0.1					
0108	BAND, POCKET	Repair Replace		0.1 0.4					
0109	LOOP, SUSPENSION LINE ATTACHING	Repair Replace		0.1 0.5					
0110	LINE, SUSPENSION	Repair Replace		0.3 0.5					
0111	RISER	Repair Replace		0.2 0.5					
02	BAG, DEPLOYMENT	Inspect Service Repair Replace		0.2 0.1 0.3 0.1					A,B,D
0201	LOOP, ATTACHING	Repair Replace		0.1 0.3					

Table 1. Maintenance Allocation Chart for 26-Foot Diameter Parachute Assembly – Continued.

(1) Group Number	(2) Component/ Assembly	(3) Maintenance Function	(4) Maintenance Level					(5) Tools & Equipment Reference Code	(6) Remarks Code
			Field			Sustainment			
			Crew	Service	Field	Below Depot	Depot		
			C	O	F	H	D		
0202	MAIN STRAP (SIDE AND CENTER)	Repair Replace		0.1 0.3					
0203	STATIC LINE RETAINING STRAP	Repair Replace		0.3 0.1					
0204	SUSPENSION LINE RETAINING STRAP	Repair Replace		0.1 0.3					
0205	TIE LOOPS	Repair Replace		0.1 0.3					
0206	PANELS AND FLAPS	Repair		0.2					
03	STATIC LINE	Inspect Service Repair Replace		0.1 0.1 0.1 0.3					
0301	STATIC LINE CLEVIS	Repair Replace		0.1 0.1					
04	USL (UNIVERSAL STATIC LINE) CARGO PARACHUTE	Replace		0.1					

Table 2. Tools and Test Equipment.

(1) TOOL OR TEST EQUIPMENT REFERENCE CODE	(2) MAINTENANCE LEVEL	(3) NOMENCLATURE	(4) NATIONAL STOCK NUMBER (NSN)	(5) TOOL NUMBER P/N
1	0	Brush, Scrub, Household	7920-00-282-2470	A-A-2074
2	0	Brush, Stenciling	7520-00-248-9285	H-B-621
3	0	File, Flat, 10-in	5110-00-249-2850	GGG-F-325
4	0	Iron, Household	7290-00-148-7068	16210
5	0	Knife	5110-00-162-2705	A-A-59100
6	0	Knife, Hot Metal	Local Purchase	4025
7	0	Line Separator	1670-00-092-8661	11-1-3512
8	0	Machine, Stencil Cutting, 1-inch	7490-00-164-0537	A-A.2722
9	0	Needle, Upholstery #5 size	8315-00-237-4959	A-A-55066
10	0	Packing Paddle	1670-00-764-6381	11-1-152
11	0	Packing Weight	1670-00-375-9134	66C38599
12	0	Pot, Melting, Electric	5120-01-249-0380	WP2/A-19-1
13	0	Shears	5110-00-223-6370	GGG-S-278
14	0	Sewing Machine, Light-Duty	3530-01-177-8590	
15	0	Sewing Machine, Zig-Zag, Medium-Duty	3530-01-181-1421	
16	0	Sewing Machine, Zig-Zag, Light-Duty	3530-01-181-1420	
17	0	Sewing Machine, Heavy-Duty	3530-01-177-8588	
18	0	Sewing Machine, Medium-Duty	3530-01-177-8591	
19	0	Sewing Machine, Darning	3530-01-177-8589	
20	0	Sewing Machine, Double-Needle	3530-01-182-2873	
21	0	Tension Plate	1670-00-032-2705	11-1-99
22	0	Yardstick	5120-00-985-6610	GGG-Y-0035
23	0	Splicing Aid	See WP 0051	

Table 3. Remarks.

(1) REFERENCE CODE	(2) REMARKS
A	Inspect is a technical-rigger type inspection.
B	Service is to clean equipment.
C	Service is the packing of parachutes.
D	Repair by restitching, darning or restenciling canopy panel.

END OF WORK PACKAGE

**26-FOOT DIAMETER, HIGH-VELOCITY CARGO PARACHUTE ASSEMBLY
EXPENDABLE/DURABLE SUPPLIES AND MATERIALS LIST**

INTRODUCTION

Scope

This work package lists expendable and durable items that you will need to operate and maintain the 26-Foot Diameter, High-Velocity Cargo Parachute. This list is for information only and is not authority to requisition the listed items. These items are authorized to you by CTA 50-970, Expendable/Durable Items (Except Medical, Class V Repair Parts, and Heraldic Items), CTA 50-909, Field and Garrison Furnishings and Equipment or CTA 8-100, Army Medical Department Expendable/Durable Items.

Explanation of Columns in the Expendable/Durable Items List

Column (1) Item No. This number is assigned to the entry in the list and is referenced in the narrative instructions to identify the item (e.g., Use brake fluid (WP 0098, item 5)).

Column (2) Level. This column identifies the lowest level of maintenance that requires the listed item (include as applicable: C = Crew, O = Service/AMC, F = Field/ASB, H = Below Depot, D = Depot).

Column (3) National Stock Number (NSN). This is the NSN assigned to the item which you can use to requisition it.

Column (4) Item Name, Description, Part Number/(CAGEC). This column provides the other information you need to identify the item. The last line below the description is the part number and the Commercial and Government Entity Code (CAGEC) (in parentheses).

Column (5) U/I. Unit of Issue (U/I) code shows the physical measurement or count of an item, such as gallon, dozen, gross, etc.

Table 1. Expendable and Durable Items List.

(1) Item No.	(2) Level	(3) National Stock Number (NSN)	(4) Item Name, Description, Part Number/(CAGEC)	(5) U/I
1	O	1670-00-568-0323	BAND, RETAINING, RUBBER, MIL-B-1832 (81349)	BX
2	O	9160-00-253-1171	BEESWAX, TECHNICAL, 1 LB, C-B-191 (81348)	LB
3	O	7920-00-282-2470	BRUSH, SCRUB, HOUSEHOLD, A-A-2074 (81348)	EA

Table 1. Expendable and Durable Items List—Continued.

(1) Item No.	(2) Level	(3) National Stock Number (NSN)	(4) Item Name, Description, Part Number/(CAGEC)	(5) U/I
4	O	7520-00-248-9285	BRUSH, STENCILING, H-B-00621 (81348)	EA
5	O	7930-001-506-9885	CLEANING COMPOUND (EVERBLUM GOLD™)	GL
6	O	5350-00-221-0872	CLOTH, ABRASIVE, FERRIC OXIDE & QUARTZ, P-C-458 (81348)	SH
7	O	8305-00-460-4200	CLOTH, COTTON, BALLOON, COATED, MIL-C-43677 (81349)	YD
8	O	8305-00-185-9731	CLOTH, COTTON, DUCK, TYPE III, 12 .29 OZ OD, CCC-C-419 (81348)	YD
9	O	8305-00-149-1563	CLOTH, COTTON, SATEEN, CLASS II, 8. 5 OZ OD, MIL-DTL-431915 (81349)	YD
10	O	8305-00-926-1559	CLOTH, MUSLIN, TYPE II, 3.5 OZ OD, 60 IN, A-A-50145 (81349)	YD
11	O	8305-01-497-1230	CLOTH, POLYESTER & COTTON 2, 3. 5 OZ OD, AA-50145 (81349)	YD
12	O	4020-00-240-2154	CORD, NYLON, TYPE I, NATURAL, MIL-C-5040 (81349)	SL
13	O	4020-00-246-0688	CORD, NYLON, TYPE II, CORELESS OD, MIL-C-7515 (81349)	SL
14	O	4020-00-782-5414	CORD, NYLON, TYPE III, OD, MIL-C-5040 (81349)	SL
15	O	7930-00-281-4731	DISHWASHING COMPOUND, HAND, FLAKE, P-D-410 (81349)	CO
16	O	7510-00-286-5362	INK, MARKING, PARACHUTE, STRATA BLUE, MIL-I-6903 (81349)	PT
17	O	9150-01-260-2534	LUBRICANT, SOLID FILM, MIL-L-23398 (81348)	CN
18	O	7520-00-230-2734	MARKER, FELT TIP, BLUE, GG-M-00114 (81348)	EA
19	O	Local Purchase	MEDICINE DROPPER	EA

Table 1. Expendable and Durable Items List—Continued.

(1) Item No.	(2) Level	(3) National Stock Number (NSN)	(4) Item Name, Description, Part Number/(CAGEC)	(5) U/I
20	O	7520-00-491-2917	PEN, BALLPOINT, GG-B-60 (81348)	EA
21	O	7510-00-240-1525	PENCIL, MARKING AID, WHITE, SS-P-196 (81348)	DZ
22	O	7510-00-264-4612	PENCIL, MARKING AID, YELLOW, SS-P-196 (81348)	DZ
23	O	5315-00-012-0123	PIN, COTTER, MS24665-355 (96906)	EA
24	O	7920-00-205-1711	RAG, WIPING, DDD-R-30 (81348)	BE
25	O	4030-00-678-8560	SHACKLE, CLEVIS, MS780086-1 (96906)	EA
26	O	9310-00-160-7858	STENCILBOARD, OILED, UU-S-625 (81348)	SH
27	O	4020-00-753-6555	TAPE, LACING AND TYING, NYLON, MIL-T-43435 (81348)	YD
28	O	8315-00-255-7673	TAPE, NYLON, TYPE III, ½ IN, MIL-T-5038 (81349)	YD
29	O	8315-00-176-8083	TAPE, NYLON, TYPE III, ¾ IN, MIL-T-5038	YD
30	O	7510-0-146-7767	TAPE, PRESSURE SENSITIVE, 1 INCH, PPP-T-60 TAN (81348)	RO
31	O	8310-00-917-3945	THREAD, COTTON, TICKET NO 8/7, V-T-276 (81348)	TU
32	O	8310-00-262-3324	THREAD, NYLON, SIZE A, NATURAL, V-T-295 (81348)	TU
33	O	8310-00-262-2770	THREAD, NYLON, SIZE E, NATURAL, V-T-295 (81348)	TU
34	O	8310-00-262-2772	THREAD, NYLON, SIZE E, OD, V-T-295 (81348)	TU

Table 1. Expendable and Durable Items List—Continued.

(1) Item No.	(2) Level	(3) National Stock Number (NSN)	(4) Item Name, Description, Part Number/(CAGEC)	(5) U/I
35	O	8310-00-248-9714	THREAD, NYLON, SIZE 3, NAT WHITE, V-T-295 (81348)	TU
36	O	8310-00-227-1244	THREAD, NYLON, SIZE FF, OD, V-T-295 (81348)	TU
37	O	8310-00-267-3027	THREAD, NYLON, SIZE 3, OD, V-T-295 (81348)	TU
38	O	8310-00-248-9716	THREAD, NYLON, SIZE 6, NAT WHITE, V-T-295 (81348)	TU
39	O	8310-00-262-2780	THREAD, NYLON, SIZE 6, OD, V-T-295 (81348)	TU
40	O	9160-00-282-2044	WAX, PARAFFIN, TECHNICAL, TYPE I, GRADE A, 1 LB, VV-W-95 (81348)	LB
41	O	8305-00-268-2411	WEBBING, COTTON, TYPE I, ¼ IN WHITE, MIL-T-5661 (81349)	YD
42	O	8305-00-281-3315	WEBBING, COTTON, TYPE II, CLASS 2B, OD, MIL-W-5665 (81349)	YD
43	O	8305-00-260-2564	WEBBING, COTTON, TYPE VIII, CLASS 2B, OD, MIL-W-5665 (81349)	YD
44	O	8305-00-261-8585	WEBBING, NYLON, TYPE VIII, OD, MIL-W-4088 (81349)	YD
45	O	8305-00-082-5751	WEBBING, NYLON TUBULAR, ¾ IN, NAT, MIL-W-5625 (81349)	YD
46	O	8305-00-268-2453	WEBBING, NYLON TUBULAR, ½ IN, MIL-W-5625 (81349)	YD
47	O	8305-00-892-4616	WIRE, STEEL, 0.08-INCH DIA. QQ-W-423 (81348)	CL

END OF WORK PACKAGE

**ILLUSTRATED LIST OF MANUFACTURED ITEMS, 26-FOOT DIAMETER, HIGH-VELOCITY
CARGO PARACHUTE ASSEMBLY**

INITIAL SETUP:

Not applicable.

INTRODUCTION**Scope**

This work package includes complete instructions for making items authorized to be manufactured or fabricated at the Field maintenance level.

How to Use the Index of Manufactured Items

A part number index in alphanumeric order is provided for cross-referencing the part number of the item to be manufactured to the information which covers fabrication criteria.

Explanation of the Illustrations of Manufactured Items

All instructions needed by maintenance personnel to manufacture the item are included on the illustrations. All bulk materials needed for manufacture of an item are listed by part number or specification number in a tabular list on the illustration.

NOTE

Item will be locally manufactured. The steel wire to be used in fabrication is listed in the Expendable and Durable Items List, WP 50.

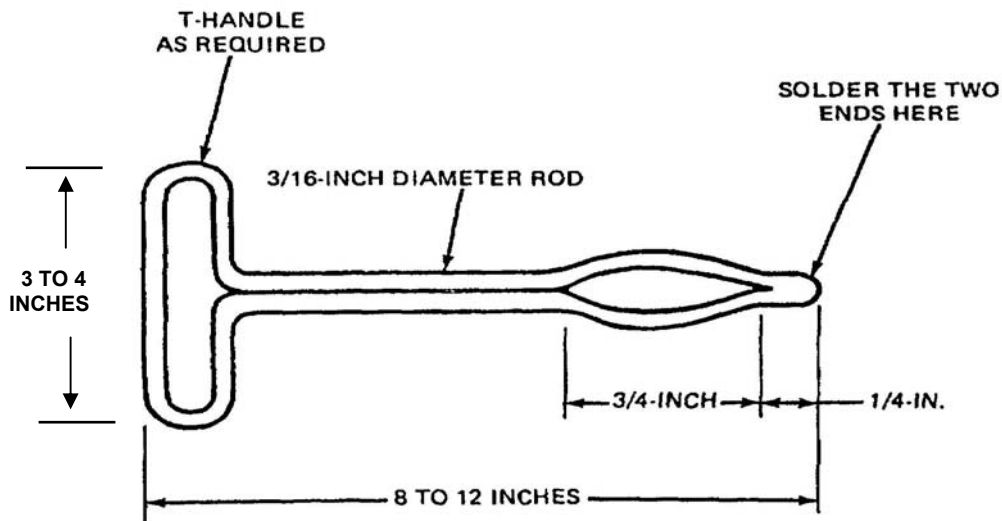

Figure 1. Splicing Aid Fabrication.

INDEX

<u>Subject</u>	<u>WP Sequence No. – Page No.</u>
A	
Accordion Folding/Rigger Rolling.....	WP 0037
Acidity Test.....	WP 0008
After-Use Receipt of Equipment.....	WP 0003
Assembling Parachute.....	WP 0004
B	
Bridle Loop (Attachment Loop).....	WP 0015
C	
Canopy Gore Section – Repair, Replace.....	WP 0034
Canopy Patching.....	WP 0034
Checking Unpacked Equipment After Shipment.....	WP 0003
Cleaning and Drying.....	WP 0008
Common Tools and Equipment.....	WP 0001
D	
Deployment Bag.....	WP 0025
Deployment Bag Attaching Loop.....	WP 0026
Deployment Bag Main Strap.....	WP 0027
Deployment Bag Panels and Flaps.....	WP 0031
Deployment Bag Static Line Retaining Strap.....	WP 0028
Deployment Bag Tie Loops.....	WP 0030
Destruction of Army Materiel to Prevent Enemy Use.....	WP 0001
E	
Equipment Characteristics, Capabilities and Features.....	WP 0002
Equipment Data.....	WP 0002
Expendable/Durable Supplies and Materials List.....	WP 0050
F	
G	
General Information – PMCS.....	WP 0006
H	
I	
Illustrated list of Manufactured Items.....	WP 0051

<u>Subject</u>	<u>WP Sequence No. – Page No.</u>
I - continued	
Initial Receipt.....	WP 0003
Inspection.....	WP 0009
In-Storage Inspection.....	WP 0009
J,K	
L	
Location and Description of Major Components.....	WP 0002
Lower Lateral Band – Repair.....	WP 0020
M	
Maintenance Allocation Chart.....	WP 0049
Maintenance Forms and Records.....	WP 0001
Marking and Restenciling.....	WP 0014
N,O	
P	
Packing the 26-ft Diameter Cargo Parachute.....	WP 0011
PMCS Procedures.....	WP 0006
Pocket Band.....	WP 0021
Preparation for Storage or Shipment.....	WP 0037
Q	
R	
Radial Tape.....	WP 0018
Receipt of Used Parachute.....	WP 0003
References.....	WP 0048
Repair Parts.....	WP 0040
Repair Parts and Special Tools List (RPSTL).....	WP 0040
Repair – Sewing Procedures.....	WP 0012
Reporting of Equipment Improvement Recommendations (EIR).....	WP 0001
Rigger Rolling/Accordion Folding.....	WP 0037
Riser – Repair.....	WP 0024
S	
Safety, Care and Handling.....	WP 0001
Salt-Water Contamination Test.....	WP 0010
Scope of Manual.....	WP 0001
Searing and Waxing.....	WP 0013
Shipment.....	WP 0037
Shakeout and Airing.....	WP 0007
Special Tools, TMDE and Support Equipment.....	WP 0001
Static Line.....	WP 0032
Static Line Clevis.....	WP 0033

Subject

WP Sequence No. – Page No.

S - continued

Storage.....	WP 0037
Suspension Lines – Repair.....	WP 0036
Suspension Line Attaching Loop.....	WP 0035

T, U

V

Vent Lines.....	WP 0016
Vent Reinforcement Tape (Upper Lateral Band) – Repair.....	WP 0017
Vertical Tape.....	WP 0019

W, X, Y, Z

**ARMY TM 10-1670-276-23&P
AIR FORCE TO 13C5-29-2
NAVY NAVAIR 13-1-29**

ROO1

By Order of the Secretaries of the Army, Air Force, and Navy (including the Marine Corps):

GEORGE W. CASEY, JR.
*General, United States Army
Chief of Staff*

Official:

JOYCE E. MORROW
*Administrative Assistant to the
Secretary of the Army*
0806301

T. MICHAEL MOSELY
*GENERAL, USAF
Chief of Staff*

BRUCE CARLSON
*General, USAF
Commander, Air Force Materiel Command*

D.G. MORRAL
*Rear Admiral, USN
Program Executive Officer
For Expeditionary Warfare
Naval Sea Systems Command*

DISTRIBUTION:

To be distributed in accordance with initial distribution number (IDN) 255061 requirements for TM 10-1670-276-23&P.

These are the instructions for sending an electronic 2028

The following format must be used if submitting an electronic 2028. The subject line must be exactly the same and all fields must be included; however only the following fields are mandatory: 1, 3, 4,5, 6, 7, 8, 9, 10, 13, 15, 16, 17, and 27.

From: "Whomever" whomever@avma27.army.mil

To: soldier.pubs@us.army.mil

Subject: DA Form 2028

1. **From:** Joe Smith
2. **Unit:** home
3. **Address:** 4300 Park
4. **City:** Hometown
5. **St:** MO
6. **Zip:** 77777
7. **Date Sent:** 19-OCT-93
8. **Pub no:** 55-2840-229-23
9. **Pub Title:** TM
10. **PublicationDate:** 04-JUL-85
11. **Change Number:** 7
12. **Submitter Rank:** MSG
13. **Submitter FName:** Joe
14. **Submitter MName:**T
15. **Submitter LName:** Smith
16. **Submitter Phone:** (123) 123-1234
17. **Problem:** 1
18. **Page:** 2
19. **Paragraph:** 3
20. **Line:** 4
21. **NSN:** 5
22. **Reference:** 6
23. **Figure:** 7
24. **Table:** 8
25. **Item:** 9
26. **Total:** 123
27. **Text:**

This is the text for the problem below line 27.

RECOMMENDED CHANGES TO PUBLICATIONS AND BLANK FORMS For use of this form, see AR 25-30; the proponent agency is ODISC4.						Use Part II (reverse) for Repair Parts and Special Tool Lists (RPSTL) and Supply Catalogs/Supply Manuals (SC/SM).	DATE 21 October 2003
TO: (Forward to proponent of publication or form) (Include ZIP Code) COMMANDER TACOM Life Cycle Management Command ATTN: AMSTA-LC-SECT 15 KANSAS STREET NATICK, MA 01760-5052						FROM: (Activity and location) (Include ZIP Code) <i>PFC Jane Doe</i> <i>CO A 3rd Engineer BR</i> <i>Ft. Leonardwood, MO 63108</i>	
PART I – ALL PUBLICATIONS (EXCEPT RPSTL AND SC/SM) AND BLANK FORMS							
PUBLICATION/FORM NUMBER TM 10-1670-296-23&P				DATE 30 October 2002	TITLE Unit Manual for Ancillary Equipment for Low Velocity Air Drop Systems		
ITEM NO.	PAGE NO.	PARA-GRAPH	LINE NO. *	FIGURE NO.	TABLE NO.	RECOMMENDED CHANGES AND REASON <i>(Provide exact wording of recommended changes, if possible).</i>	
	0036 00-2				1	<i>In table 1, Sewing Machine Code Symbols, the second sewing machine code symbol should be MD ZZ not MD 22.</i> <i>Change the manual to show Sewing Machine, Industrial: Zig-Zag; 308 stitch; medium-duty; NSN 3530-01-181-1421 as a MD ZZ code symbol.</i>	
<small>*Reference to line numbers within the paragraph or subparagraph.</small>							
TYPED NAME, GRADE OR TITLE Jane Doe, PFC				TELEPHONE EXCHANGE/AUTOVON, PLUS EXTENSION 508-233-4141		SIGNATURE Jane Doe <i>Jane Doe</i>	

TO: <i>(Forward direct to addressee listed in publication)</i> COMMANDER TACOM Life Cycle Management Command ATTN: AMSTA-LC-SECT 15 KANSAS STREET NATICK, MA 01760-5052	FROM: <i>(Activity and location) (Include ZIP Code)</i> <i>PFC Jane Doe</i> <i>CO A 3rd Engineer BR</i> <i>Ft. Leonardwood, MO 63108</i>	DATE <i>21 October 2003</i>
---	---	---------------------------------------

PART II – REPAIR PARTS AND SPECIAL TOOL LISTS AND SUPPLY CATALOGS/SUPPLY MANUALS

PUBLICATION NUMBER TM 10-1670-296-23&P	DATE 30 October 2002	TITLE Unit Manual for Ancillary Equipment for Low Velocity Air Drop Systems
--	--------------------------------	---

PAGE NO.	COLM NO.	LINE NO.	NATIONAL STOCK NUMBER	REFERENCE NO.	FIGURE NO.	ITEM NO.	TOTAL NO. OF MAJOR ITEMS SUPPORTED	RECOMMENDED ACTION
0066 00-1					4			<i>Callout 16 in figure 4 is pointed to a <u>D-Ring</u>. In the Repair Parts List key for figure 4, item 16 is called a <u>Snap Hook</u>. Please correct one or the other.</i>

SAMPLE

PART III – REMARKS *(Any general remarks or recommendations, or suggestions for improvement of publications and blank forms. Additional blank sheets may be used if more space is needed.)*

TYPED NAME, GRADE OR TITLE	TELEPHONE EXCHANGE/AUTOVON, PLUS EXTENSION	SIGNATURE
----------------------------	--	-----------

RECOMMENDED CHANGES TO PUBLICATIONS AND BLANK FORMS						Use Part II (reverse) for Repair Parts and Special Tool Lists (RPSTL) and Supply Catalogs/Supply Manuals (SC/SM).	DATE
For use of this form, see AR 25-30; the proponent agency is ODISC4.							
TO: (Forward to proponent of publication or form) (Include ZIP Code) COMMANDER TACOM Life Cycle Management Command ATTN: AMSTA-LC-SECT 15 KANSAS STREET NATICK, MA 01760-5052						FROM: (Activity and location) (Include ZIP Code)	
PART I – ALL PUBLICATIONS (EXCEPT RPSTL AND SC/SM) AND BLANK FORMS							
PUBLICATION/FORM NUMBER TM 10-1670-276-23&P				DATE 14 March 2008		TITLE Field Maintenance Manual (Including Repair Parts and Special Tools List) for Parachute, Cargo Type: 26-Foot Diameter, High-Velocity	
ITEM NO.	PAGE NO.	PARA-GRAPH	LINE NO. *	FIGURE NO.	TABLE NO.	RECOMMENDED CHANGES AND REASON <i>(Provide exact wording of recommended changes, if possible).</i>	
<i>*Reference to line numbers within the paragraph or subparagraph.</i>							
TYPED NAME, GRADE OR TITLE				TELEPHONE EXCHANGE/AUTOVON, PLUS EXTENSION		SIGNATURE	

TO: <i>(Forward direct to addressee listed in publication)</i> COMMANDER TACOM Life Cycle Management Command ATTN: AMSTA-LC-SECT 15 KANSAS STREET NATICK, MA 01760-5052	FROM: <i>(Activity and location) (Include ZIP Code)</i>	DATE
---	--	-------------

PART II – REPAIR PARTS AND SPECIAL TOOL LISTS AND SUPPLY CATALOGS/SUPPLY MANUALS

PUBLICATION NUMBER TM 10-1670-276-23&P	DATE 14 March 2008	TITLE Field Maintenance Manual (Including Repair Parts and Special Tools List) for Parachute, Cargo Type: 26-Foot Diameter, High-Velocity
---	-----------------------	--

PAGE NO.	COLM NO.	LINE NO.	NATIONAL STOCK NUMBER	REFERENCE NO.	FIGURE NO.	ITEM NO.	TOTAL NO. OF MAJOR ITEMS SUPPORTED	RECOMMENDED ACTION

PART III – REMARKS *(Any general remarks or recommendations, or suggestions for improvement of publications and blank forms. Additional blank sheets may be used if more space is needed.)*

TYPED NAME, GRADE OR TITLE	TELEPHONE EXCHANGE/AUTOVON, PLUS EXTENSION	SIGNATURE
----------------------------	--	-----------

RECOMMENDED CHANGES TO PUBLICATIONS AND BLANK FORMS						Use Part II (reverse) for Repair Parts and Special Tool Lists (RPSTL) and Supply Catalogs/Supply Manuals (SC/SM).	DATE
For use of this form, see AR 25-30; the proponent agency is ODISC4.							
TO: (Forward to proponent of publication or form) (Include ZIP Code) COMMANDER TACOM Life Cycle Management Command ATTN: AMSTA-LC-SECT 15 KANSAS STREET NATICK, MA 01760-5052						FROM: (Activity and location) (Include ZIP Code)	
PART I – ALL PUBLICATIONS (EXCEPT RPSTL AND SC/SM) AND BLANK FORMS							
PUBLICATION/FORM NUMBER TM 10-1670-276-23&P				DATE 14 March 2008		TITLE Field Maintenance Manual (Including Repair Parts and Special Tools List) for Parachute, Cargo Type: 26-Foot Diameter, High-Velocity	
ITEM NO.	PAGE NO.	PARA-GRAPH	LINE NO. *	FIGURE NO.	TABLE NO.	RECOMMENDED CHANGES AND REASON <i>(Provide exact wording of recommended changes, if possible).</i>	
<i>*Reference to line numbers within the paragraph or subparagraph.</i>							
TYPED NAME, GRADE OR TITLE				TELEPHONE EXCHANGE/AUTOVON, PLUS EXTENSION			SIGNATURE

TO: <i>(Forward direct to addressee listed in publication)</i> COMMANDER TACOM Life Cycle Management Command ATTN: AMSTA-LC-SECT 15 KANSAS STREET NATICK, MA 01760-5052	FROM: <i>(Activity and location) (Include ZIP Code)</i>	DATE
---	--	-------------

PART II – REPAIR PARTS AND SPECIAL TOOL LISTS AND SUPPLY CATALOGS/SUPPLY MANUALS

PUBLICATION NUMBER TM 10-1670-276-23&P	DATE 14 March 2008	TITLE Field Maintenance Manual (Including Repair Parts and Special Tools List) for Parachute, Cargo Type: 26-Foot Diameter, High-Velocity
---	-----------------------	--

PAGE NO.	COLM NO.	LINE NO.	NATIONAL STOCK NUMBER	REFERENCE NO.	FIGURE NO.	ITEM NO.	TOTAL NO. OF MAJOR ITEMS SUPPORTED	RECOMMENDED ACTION

PART III – REMARKS *(Any general remarks or recommendations, or suggestions for improvement of publications and blank forms. Additional blank sheets may be used if more space is needed.)*

TYPED NAME, GRADE OR TITLE	TELEPHONE EXCHANGE/AUTOVON, PLUS EXTENSION	SIGNATURE
----------------------------	--	-----------

RECOMMENDED CHANGES TO PUBLICATIONS AND BLANK FORMS						Use Part II (reverse) for Repair Parts and Special Tool Lists (RPSTL) and Supply Catalogs/Supply Manuals (SC/SM).	DATE
For use of this form, see AR 25-30; the proponent agency is ODISC4.							
TO: (Forward to proponent of publication or form) (Include ZIP Code) COMMANDER TACOM Life Cycle Management Command ATTN: AMSTA-LC-SECT 15 KANSAS STREET NATICK, MA 01760-5052						FROM: (Activity and location) (Include ZIP Code)	
PART I – ALL PUBLICATIONS (EXCEPT RPSTL AND SC/SM) AND BLANK FORMS							
PUBLICATION/FORM NUMBER TM 10-1670-276-23&P				DATE 14 March 2008		TITLE Field Maintenance Manual (Including Repair Parts and Special Tools List) for Parachute, Cargo Type: 26-Foot Diameter, High-Velocity	
ITEM NO.	PAGE NO.	PARA-GRAPH	LINE NO. *	FIGURE NO.	TABLE NO.	RECOMMENDED CHANGES AND REASON <i>(Provide exact wording of recommended changes, if possible).</i>	
<i>*Reference to line numbers within the paragraph or subparagraph.</i>							
TYPED NAME, GRADE OR TITLE				TELEPHONE EXCHANGE/AUTOVON, PLUS EXTENSION		SIGNATURE	

TO: <i>(Forward direct to addressee listed in publication)</i> COMMANDER TACOM Life Cycle Management Command ATTN: AMSTA-LC-SECT 15 KANSAS STREET NATICK, MA 01760-5052	FROM: <i>(Activity and location) (Include ZIP Code)</i>	DATE
---	--	-------------

PART II – REPAIR PARTS AND SPECIAL TOOL LISTS AND SUPPLY CATALOGS/SUPPLY MANUALS

PUBLICATION NUMBER TM 10-1670-276-23&P	DATE 14 March 2008	TITLE Field Maintenance Manual (Including Repair Parts and Special Tools List) for Parachute, Cargo Type: 26-Foot Diameter, High-Velocity
---	-----------------------	--

PAGE NO.	COLM NO.	LINE NO.	NATIONAL STOCK NUMBER	REFERENCE NO.	FIGURE NO.	ITEM NO.	TOTAL NO. OF MAJOR ITEMS SUPPORTED	RECOMMENDED ACTION

PART III – REMARKS *(Any general remarks or recommendations, or suggestions for improvement of publications and blank forms. Additional blank sheets may be used if more space is needed.)*

TYPED NAME, GRADE OR TITLE	TELEPHONE EXCHANGE/AUTOVON, PLUS EXTENSION	SIGNATURE
----------------------------	--	-----------

The Metric System and Equivalents

Linear Measure

1 centimeter = 10 millimeters = .39 inch
 1 decimeter = 10 centimeters = 3.94 inches
 1 meter = 10 decimeters = 39.37 inches
 1 dekameter = 10 meters = 32.8 feet
 1 hectometer = 10 dekameters = 328.08 feet
 1 kilometer = 10 hectometers = 3,280.8 feet

Weights

1 centigram = 10 milligrams = .15 grain
 1 decigram = 10 centigrams = 1.54 grains
 1 gram = 10 decigrams = .035 ounce
 1 dekagram = 10 grams = .35 ounce
 1 hectogram = 10 dekagrams = 3.52 ounces
 1 kilogram = 10 hectograms = 2.2 pounds
 1 quintal = 100 kilograms = 220.46 pounds
 1 metric ton = 10 quintals = 1.1 short tons

Liquid Measure

1 centiliter = 10 milliliters = .34 fl. ounce
 1 deciliter = 10 centiliters = 3.38 fl. ounces
 1 liter = 10 deciliters = 33.81 fl. ounces
 1 dekaliter = 10 liters = 2.64 gallons
 1 hectoliter = 10 dekaliters = 26.42 gallons
 1 kiloliter = 10 hectoliters = 264.18 gallons

Square Measure

1 sq. centimeter = 100 sq. millimeters = .155 sq. inch
 1 sq. decimeter = 100 sq. centimeters = 15.5 sq. inches
 1 sq. meter (centare) = 100 sq. decimeters = 10.76 sq. feet
 1 sq. dekameter (are) = 100 sq. meters = 1,076.4 sq. feet
 1 sq. hectometer (hectare) = 100 sq. dekameters = 2.47 acres
 1 sq. kilometer = 100 sq. hectometers = .386 sq. mile

Cubic Measure

1 cu. centimeter = 1000 cu. millimeters = .06 cu. inch
 1 cu. decimeter = 1000 cu. centimeters = 61.02 cu. inches
 1 cu. meter = 1000 cu. decimeters = 35.31 feet

Approximate Conversion Factors

<i>To change</i>	<i>To</i>	<i>Multiply by</i>	<i>To change</i>	<i>To</i>	<i>Multiply by</i>
inches	centimeters	2.540	ounce-inches	newton-meters	.007062
feet	meters	.305	centimeters	inches	.394
yards	meters	.914	meters	feet	3.280
miles	kilometers	1.609	meters	yards	1.094
square inches	square centimeters	6.451	kilometers	miles	.621
square feet	square meters	.093	square centimeters	square inches	.155
square yards	square meters	.836	square meters	square feet	10.764
square miles	square kilometers	2.590	square meters	square yards	1.196
acres	square hectometers	.405	square kilometers	square miles	.386
cubic feet	cubic meters	.028	square hectometers	acres	2.471
cubic yards	cubic meters	.765	cubic meters	cubic feet	35.315
fluid ounces	milliliters	29.573	cubic meters	cubic yards	1.308
pints	liters	.473	milliliters	fluid ounces	.034
quarts	liters	.946	liters	pints	2.113
gallons	liters	3.785	liters	quarts	1.057
ounces	grams	28.349	liters	gallons	.264
pounds	kilograms	.454	grams	ounces	.035
short tons	metric tons	.907	kilograms	pounds	2.205
pound-feet	newton-meters	1.356	metric tons	short tons	1.102
pound-inches	newton-meters	.11296			

Temperature (Exact)

 °F Fahrenheit temperature 5/9 (after subtracting 32) Celsius temperature °C

PIN: 068099-000